

INTELLI-VENT™ CONTROL INFORMATION
When Used On Gas, Residential, Power Vented
Water Heaters

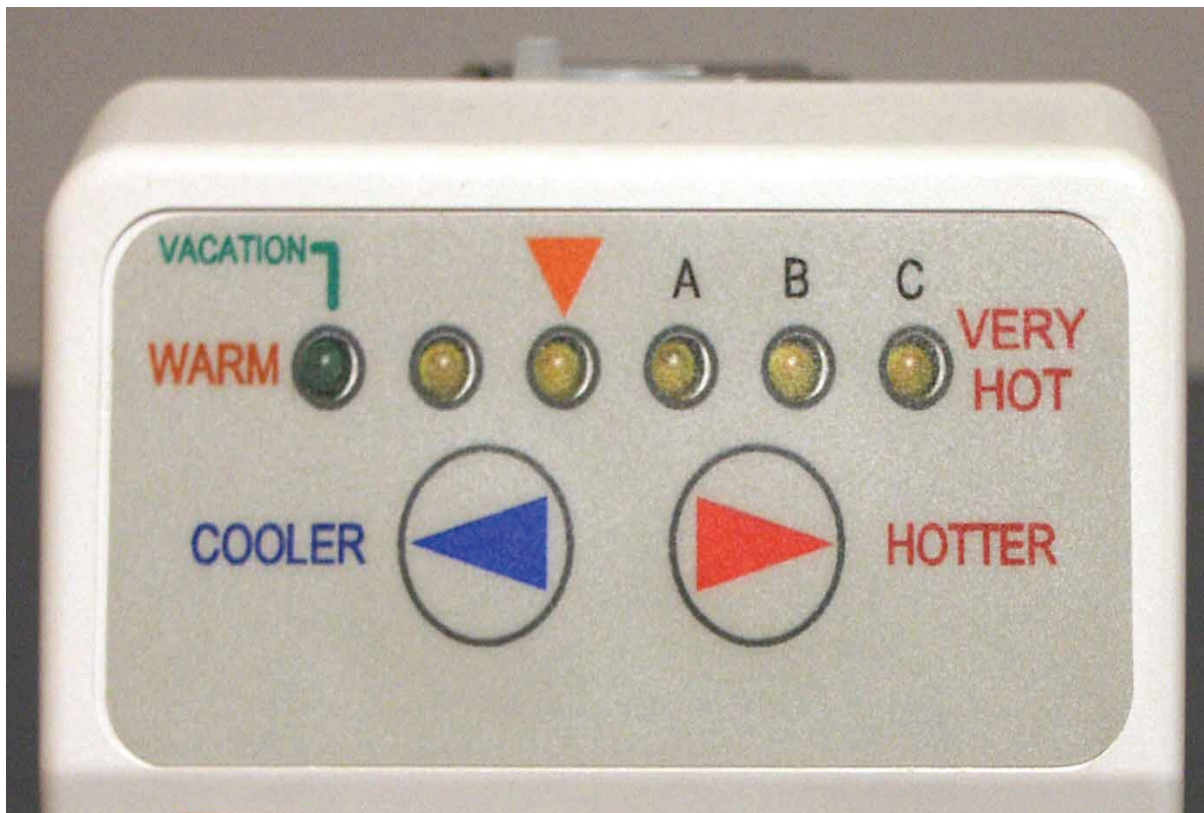

Printed in the USA – 0605

Part No. GTC-070 R3

*Revision 2 includes updated troubleshooting information for error codes 3, 4, and 6.
Revision 3 includes updated troubleshooting for error codes 4 and 6 and technical bulletins*

INTELLI-VENT TROUBLESHOOTING GUIDE

INTELLI-VENT™ FEATURES

The Intelli-Vent™ is a combination control incorporating all temperature control, ignition control, blower and ignitor control, flame sensing, and gas regulation into a single device.

Advanced Diagnostics - Error Codes

The Intelli-Vent™ features advanced diagnostics with 15 specific error codes including **reversed polarity** and inadequate **grounding** notification. Diagnostic information is conveyed via 6 LED lights on the control. These error codes will help diagnose and repair the water heater quickly and accurately.

Tamper Resistant

The Intelli-Vent™ features **tamper resistant temperature settings**. In order to access temperature settings both temperature adjust buttons must be pressed simultaneously for one full second to review the temperature settings. Temperature settings are displayed by illuminating various combinations of LED lights.

Precise Temperature Control

The Intelli-Vent™ controls temperature electronically. Tighter cut out and cut in differentials produce less temperature swing than standard residential controls.

Temperature Probe - Thermistor

The temperature probe houses the ECO and a temperature sensor which is a “thermistor.” Thermistors are thermally sensitive variable resistors. A change in water temperature changes the resistance (measured in ohms) of the thermistor. The Intelli-Vent™ control interprets this change in resistance as a change in temperature and uses this information to activate and deactivate a call for heat.

Silicon Nitride Ignitor

The Intelli-Vent™ control uses a **silicon nitride ignitor** which is more durable than the silicon carbide ignitors previously used. Body oils transferred to the ignitor during handling will not damage silicon nitride ignitors nor will minor bumps or drops. This ignitor is also highly resistant to damage caused by condensation.

Adaptive Learning Technology

Adaptive Learning Technology refers to the programmed control of voltage to the ignitor. The Intelli-Vent™ varies voltage to the ignitor and “learns” to use the lowest voltage necessary that insures consistent ignition. Lower voltage increases ignitor life.

Water Resistant

While not being a “water proof” control the Intelli-Vent control does have a greater degree of resistance to water damage than previous controls. Wiring connections are on the bottom of the control and less susceptible to damage.

INTELLI-VENT TROUBLESHOOTING GUIDE

INTELLI-VENT™ CONSTRUCTION



Manifold Gas;
Main Burner Connection

- RH thread Natural
- LH thread Propane

6 Pin Molex Plug

- Line Voltage
- Blower Voltage
- Pressure Switch

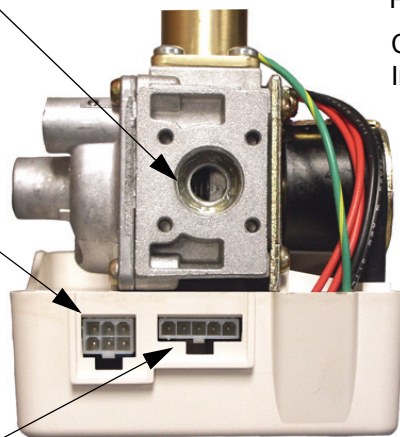

5 Pin Molex Plug

- Hot Surface Ignitor
- Flame Sensor
- Resistor Wire

Manifold Gas
Pressure Tap

Control
Information

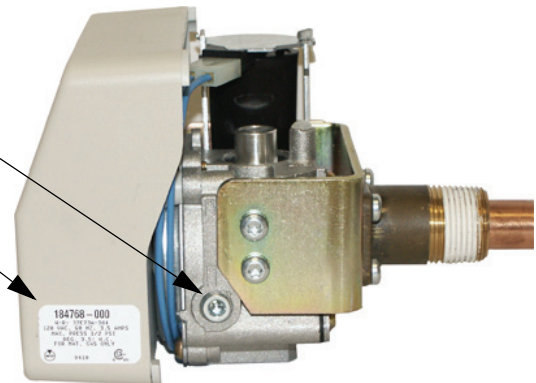

Flame Sensor

Silicon Nitride Ignitor
(Hot Surface Ignitor)

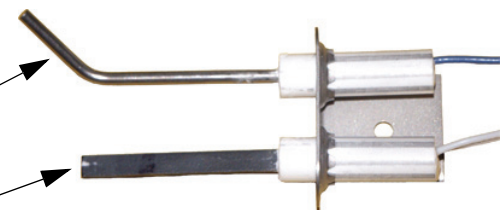

INTELLI-VENT TROUBLESHOOTING GUIDE

INTELLI-VENT™ OPERATION

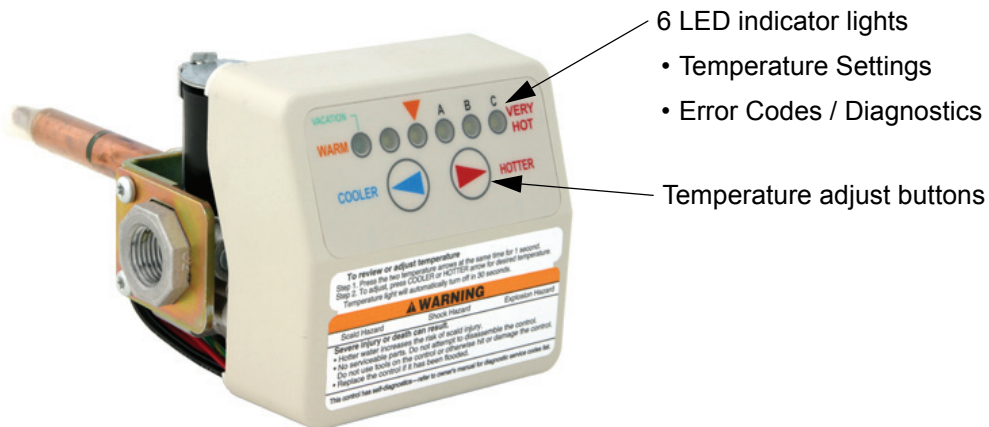

PRE START UP CHECK LIST

- Correct polarity on electrical supply
- Water heater is properly grounded
- Owner's manual safety statements have been reviewed

START UP PROCEDURE

- 1 **Plug in water heater and turn on power.** All lights on the control will come on for about 1 - 5 seconds. All lights will then turn off. If the stored water is above 70°F (residential) and the control setting has not been increased from its factory setting, nothing more will happen. (Residential controls are factory set at 70°F, the “vacation” setting per ANSI requirements; Commercial controls are factory set at 120°F)
- 2 **Wake Up the control** by holding down both of the temperature adjust buttons at the same time for about one second; then release the buttons and the LED lights will indicate the current temperature setting.
- 3 **Push then release** the “hotter” temperature adjust button repeatedly to increase the water temperature setting and the “colder” temperature adjust button to decrease the setting.

THE RECOMMENDED STARTING TEMPERATURE IS 120°F

See the illustration on the following page indicating which temperature setting corresponds to the various combinations of LED lights.

SLEEP MODE - NORMAL OPERATION

Without any further user input the control will go back into the “**sleep mode**” in 30 seconds. All LED indicator lights will turn off. This is the **normal operating mode**.

INTELLI-VENT TROUBLESHOOTING GUIDE

TEMPERATURE SETTINGS

Residential and commercial Intelli-Vent controls differ in appearance:

- The far left LED light is green on the residential control and the remaining 5 LEDs are yellow.
- On the commercial control all six LEDs are yellow.
- The residential control has a “vacation” temperature setting (70°F) and it is referenced on the display.
- There is no vacation setting on a commercial control.
- The residential control uses an inverted triangle (delta symbol) above the third LED and uses A, B, and C as temperature set point references.
- The commercial control places the inverted triangle above the far left LED and uses B, C, D, E, and F for temperature set point references.

Residential

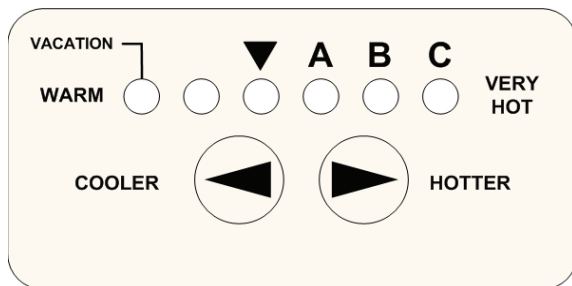

Commercial

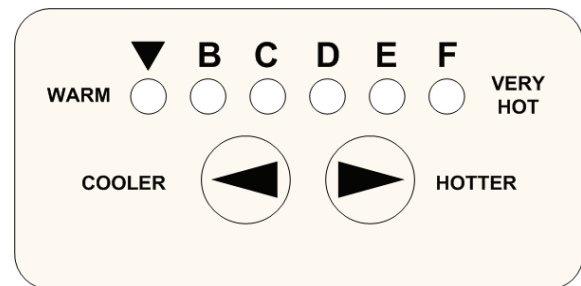

DISPLAY ▼ A B C	APPROXIMATE TEMPERATURE (°F)
● ○ ○ ○ ○ ○	70
○ ● ○ ○ ○ ○	110
○ ● ● ○ ○ ○	115
○ ○ ● ○ ○ ○	120
○ ○ ● ● ○ ○	125
○ ○ ○ ● ○ ○	130
○ ○ ○ ● ● ○	135
○ ○ ○ ○ ● ○	140
○ ○ ○ ○ ● ●	145
○ ○ ○ ○ ○ ●	150
○ ○ ○ ○ ○ ● FLASHING → ↑	160

DISPLAY ▼ B C D E F	APPROXIMATE TEMPERATURE (°F)
● ○ ○ ○ ○ ○	120
● ● ○ ○ ○ ○	130
○ ● ○ ○ ○ ○	140
○ ● ● ○ ○ ○	145
○ ○ ● ○ ○ ○	150
○ ○ ● ● ○ ○	155
○ ○ ○ ● ○ ○	160
○ ○ ○ ● ● ○	165
○ ○ ○ ○ ● ○	170
○ ○ ○ ○ ● ●	175
○ ○ ○ ○ ○ ●	180

INTELLI-VENT TROUBLESHOOTING GUIDE

INTELLI-VENT™ SPECIFICATIONS

INTELLI-VENT™ CONTROL SPECIFICATIONS	
Body	½ inch NPT inlet. ½ inch inverted flare outlet. (RH thread natural, LH thread propane)
Electrical Ratings	120 VAC, 60 Hz, 1Ø, 5-7 FLA. Ignitor load: 2 amps maximum. Blower/inducer motors: 3 amps full load - 4 amps locked rotor.
Max Inlet Gas Pressure	½ PSI maximum (14.0" W.C.)
Temperature Range	70 - 160°F Residential. 120 - 180°F Commercial.
High Temp Cut Off - ECO	195°F Residential - single use (control must be replaced) 195°F Commercial - resettable (reset temp 120°F)
OPERATING SEQUENCE	
Pre-Purge Time	5 seconds.
Ignitor Warm-up Time	20 seconds.
Trial for Ignition Period	4 seconds.
Inter-Purge Time	5 seconds.
Post-Purge Time	5 seconds.
Ignition Retries	2 retries; 3 trials before lockout.
Ignition Recycles	2 recycles, 3 losses of flame before lockout.

GAS PRESSURE REQUIREMENTS

NATURAL GAS	
Supply gas	<ul style="list-style-type: none"> 4.5 to 5.0" W.C. minimum -14.0" W.C. maximum Always check control/water heater label
†Manifold gas	<ul style="list-style-type: none"> 3.5 to 4.0" W.C. Always check control/water heater label
PROPANE GAS	
Supply gas	<ul style="list-style-type: none"> 11.0" W.C. minimum 14.0" W.C. maximum
†Manifold gas	<ul style="list-style-type: none"> 10.0" W.C.

†. Manifold gas pressure is non adjustable. Always verify correct main burner orifice before replacing a control for failing to maintain correct manifold pressure.

INTELLI-VENT TROUBLESHOOTING GUIDE

INTELLI-VENT™ WIRING CONNECTIONS

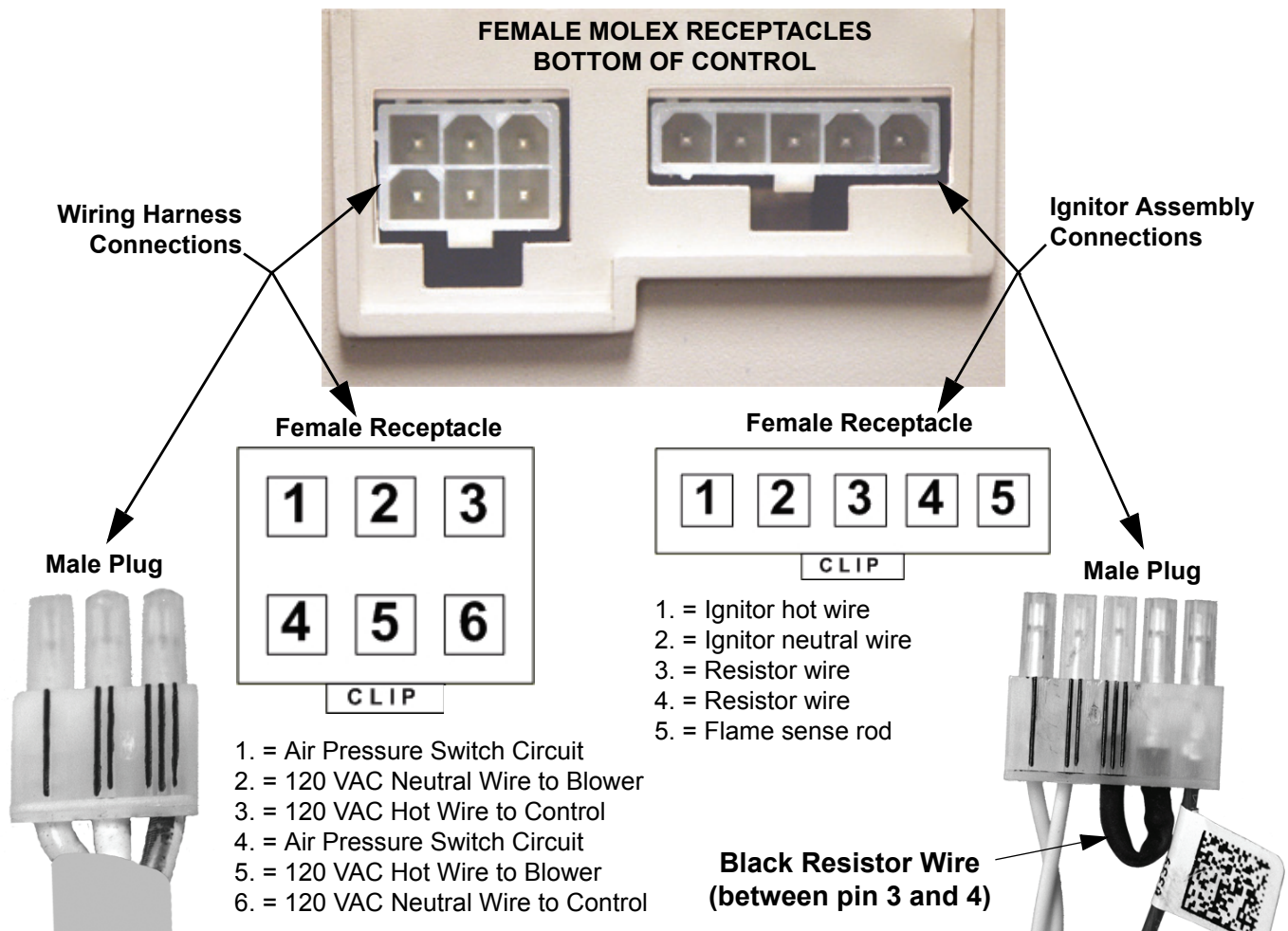

There are two female Molex plug receptacles on the bottom of the Intelli-Vent™ control. Keep in mind the receptacles (female) and plugs (male) are mirror images of each other in regard to pin number location and retaining clip orientation. Pin numbers and corresponding component wiring are detailed above in relation to the retaining clip.

The male plug ends from the 6 conductor wire harness and 5 conductor ignitor assembly plug are shown above; notice the raised ridges identifying the #1, #2, and #3 pins. A black marker was used to highlight these ridges for the photograph.

Service Notes:

The **Black Resistor Wire** on the ignitor assembly plug is used to provide proper sensory input in place of optional external variable resistance devices, none are currently used. This resistor wire must not be cut, removed, or jumpered. The Intelli-Vent control would interpret this as a component failure and lock out displaying error code 14 or 15.

Pins and sockets inside the plugs and receptacles should be visually inspected to insure good connections are being made when servicing. **Always depress retaining clip when unplugging Molex connectors, failure to do so can damage plug connection.**

INTELLI-VENT TROUBLESHOOTING GUIDE

Wiring Harness Connection Diagram

Models Equipped With Vent Temperature Limit Switch

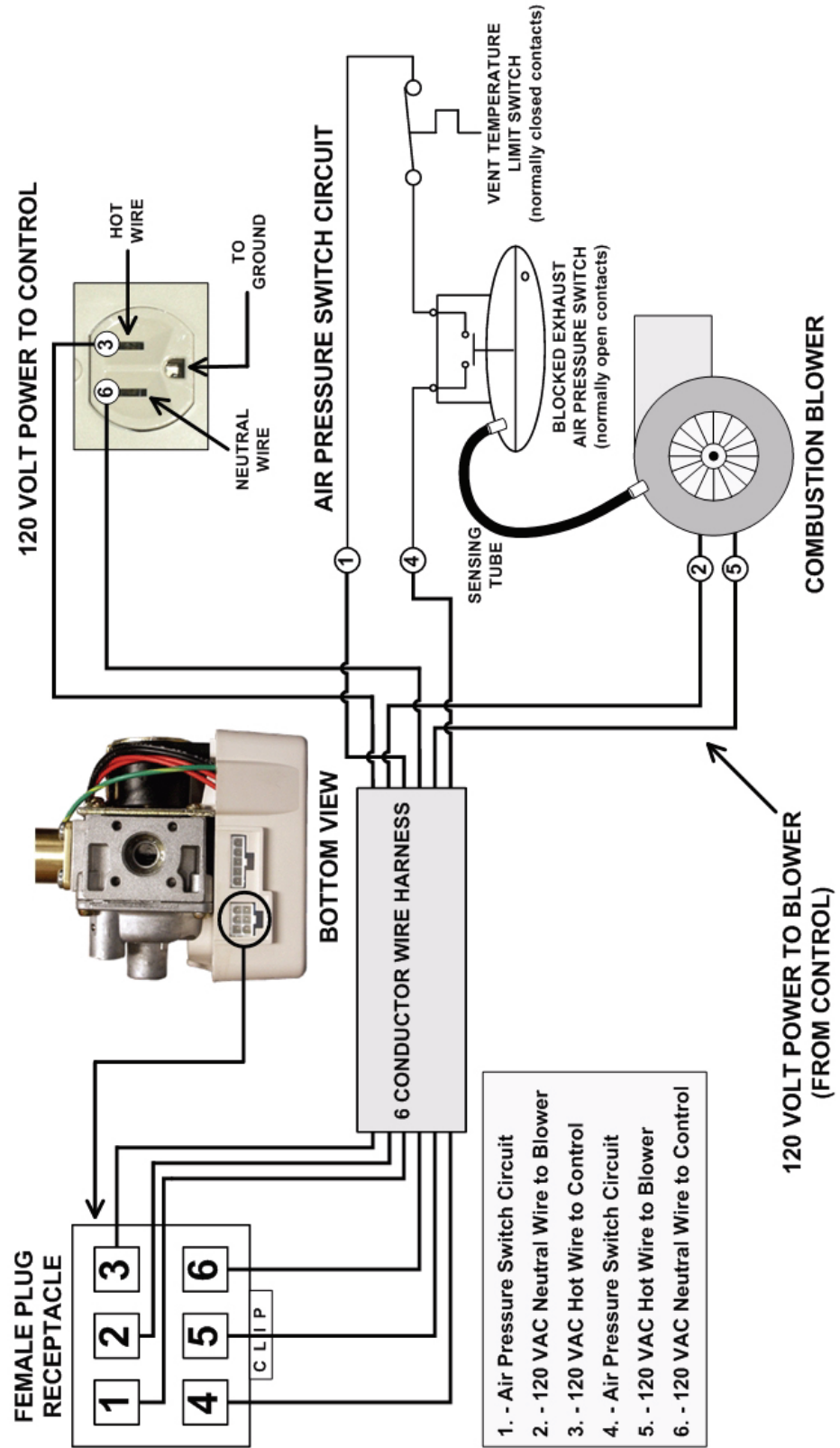

INTELLI-VENT TROUBLESHOOTING GUIDE

INTELLI-VENT™ SEQUENCE OF OPERATION

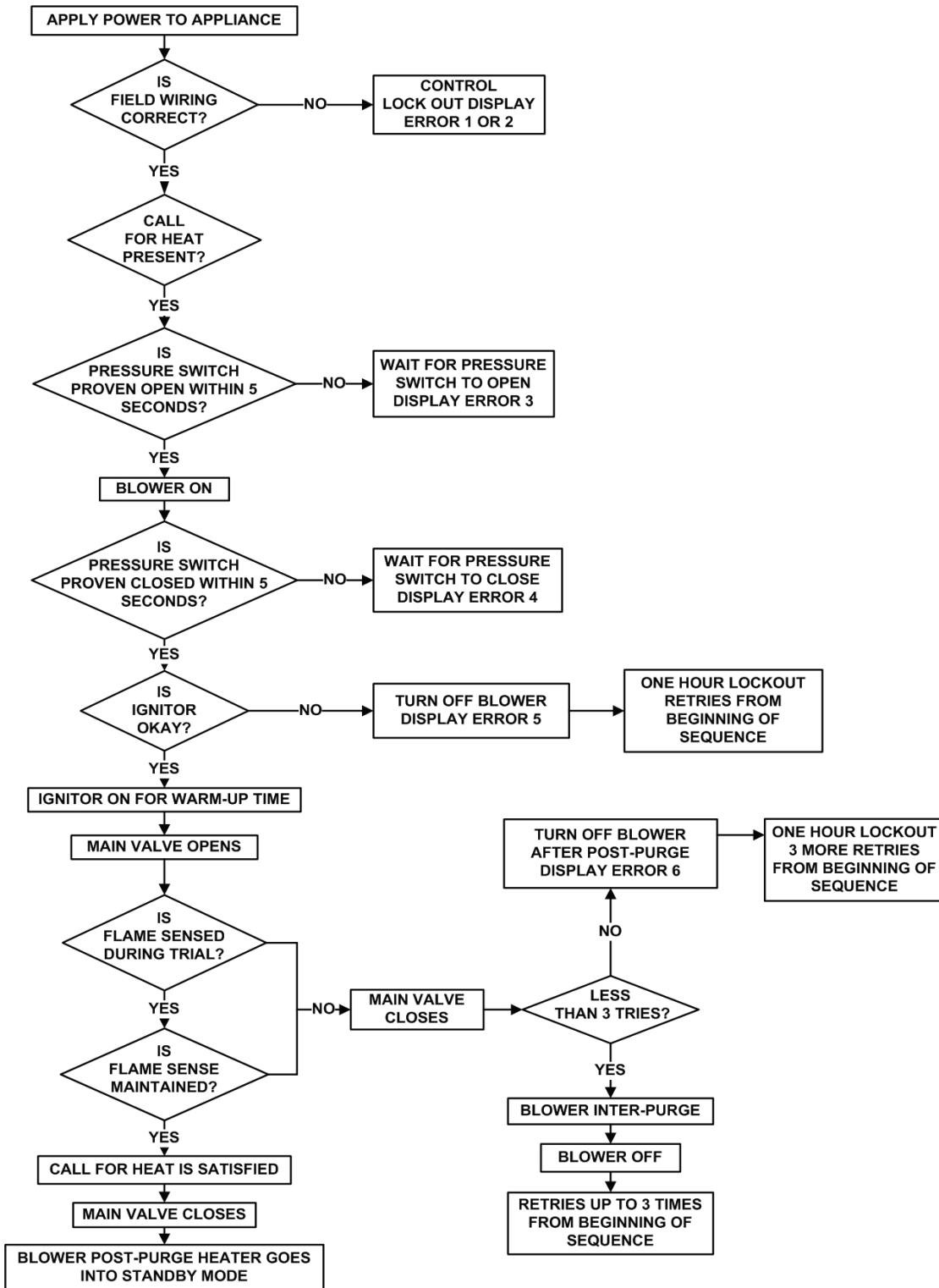

INTELLI-VENT TROUBLESHOOTING GUIDE

INTELLI-VENT™ TROUBLESHOOTING GUIDE

Error Codes & Diagnostics

The Intelli-Vent™ control will not have any LED lights illuminated during normal operation (sleep mode) for the life of the water heater. When an LED is illuminated, it draws attention to the water heater and the need to have it serviced.

There are 15 different diagnostic error codes the Intelli-Vent™ control is capable of displaying by illuminating various combinations of LED lights. All 15 are covered in the troubleshooting guide that follows.

The same combination of LED lights are used for error codes on residential and commercial controls though the way they are displayed differs slightly:

Residential controls display **error codes** via **constant illumination** of the LED lights.

Commercial controls display **error codes** by **flashing** the LED lights on and off.

Important Service/Installation Notes:

- 1 **Always turn power off** for 10 to 20 seconds and then back on again **to clear an error code before replacing an Intelli-Vent™ control.**
- 2 When installing the water heater or a replacement Intelli-Vent™ control, **do not use the control face as a handle** to move the water heater or turn (thread) the control.
- 3 When installing a replacement control **do no pinch, pull, or cut exposed wires.**

Troubleshooting Guide Notes:

- Residential error code displays are shown on the left and commercial on the right for all 15 error codes that follow.
- LEDs filled in black indicate an illuminated LED.

ERROR CODE 1 - NO EARTH GROUND

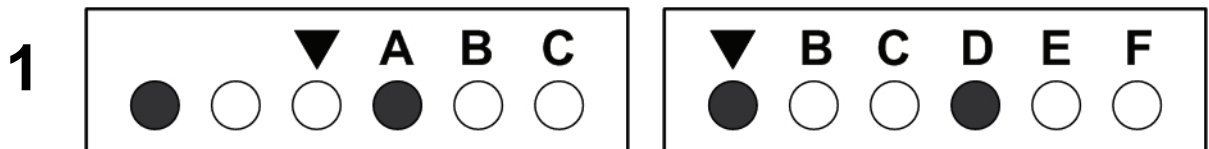

Inadequate or no earth ground sensed by Intelli-Vent™ control.

Check / Repair:

- Insure the wall outlet is properly grounded.
- Insure all ground connections on the water heater are secure.
- Insure ground path wires (if so equipped) between wiring boxes and heater jacket are properly secured.
- Insure the ground (green) wire in the power cord is continuous with an ohm meter.

INTELLI-VENT TROUBLESHOOTING GUIDE

ERROR CODE 2 - REVERSED POLARITY

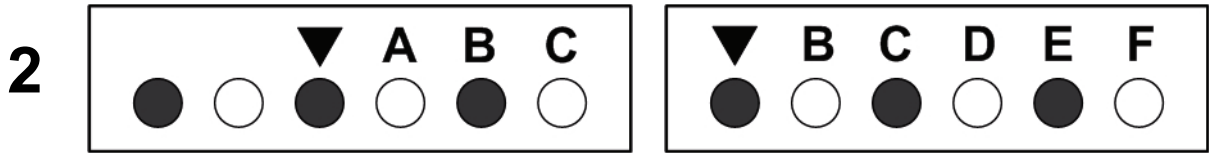

Power supply to Intelli-Vent™ control has reversed polarity.

Check / Repair:

- Insure the wall outlet is properly wired.
- Insure all internal 120 VAC wiring connections on the water heater are not reversed. 120 VAC “hot” wire should connect to the on/off switch.
- Insure the wiring harness between the Intelli-Vent control and the wiring box has no crossed wires with an ohm meter. (see 7)
- Double check all ground connections insure they are clean, tight, and intact.

ERROR CODE 3 - PRESSURE SWITCH CIRCUIT REMAINS CLOSED

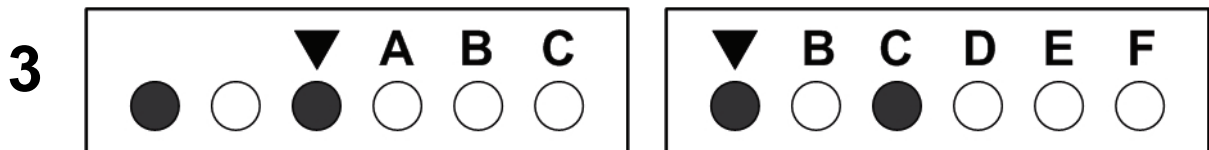

†Pressure switch circuit (see 7) remaining closed for more than 5 seconds after heating cycle is activated. Blower does not start.

Check / Repair:

- Insure air pressure switch circuit wiring is correct and the air pressure switch is not jumpered.
- Turn off power and unplug the water heater from wall outlet. Disconnect both wires from the air pressure switch terminals. Check between the wiring terminals of the air pressure switch with an ohm meter for continuity.
 - A If pressure switch contacts show continuity (closed circuit) replace the pressure switch.
 - B If pressure switch contacts show open circuit and all wiring is correct - replace Intelli-Vent control.

†. To verify a closed air pressure switch circuit is preventing the heat sequence from advancing (IE the combustion blower is not being energized): Turn off power & unplug the water heater from the wall outlet. Disconnect one wire from the air pressure switch (tape off end of wire - insure this wire does not touch ground). Plug the water heater back in and turn the power switch back on. If a call for heat is still present error code 3 should not return and the Intelli-Vent control should energize the combustion blower.

INTELLI-VENT TROUBLESHOOTING GUIDE

ERROR CODE 4 - PRESSURE SWITCH CIRCUIT REMAINS OPEN

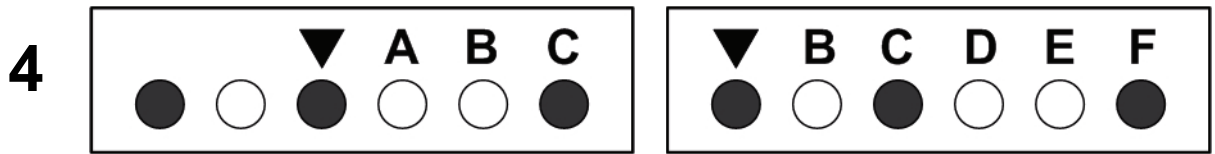

Pressure switch circuit (see 7) remains open longer than 5 seconds after the combustion blower/inducer fan was energized by the Intelli-Vent™ control. **Blower may run continuously in this condition.**

Check / Repair:

- Insure the blower is starting and coming up to speed, if the Intelli-Vent control will not energize the blower with the air pressure switch circuit open, replace the Intelli-Vent control (see footnote page10).
- Insure pressure switch wiring is correct (see wiring diagram page 7).
- Insure pressure switch sensing tube is not damaged/kinked and is properly connected.
- Insure vent system has been installed correctly: insure the correct size vent pipe was used. Insure the maximum number of elbows or equivalent feet of vent pipe has not exceeded the water heater manufacturer requirements.
- Insure a vent termination restrictor was not installed on vent installations that do not require it. **(Do not install this restrictor when it is not required)** See the A. O. Smith/ State Product Notifications for vent restrictor usage at the end of this manual.
- Clear any obstructions or restrictions in the exhaust vent or the intake air pipe.
- Defective air pressure switch; Check pressure switch contacts with ohm meter during blower operation; contacts should close (show continuity) after blower starts and comes up to speed. If air pressure switch contacts are not closing:

Take air pressure reading (see page 23) with a digital manometer at the sensing port on the blower. Compare to manufacturer's specification for switch. If pressure reading taken is at or beyond activation point according to manufacturer's specification for the switch - replace air pressure switch. If pressure reading taken does not reach activation point for switch; Check for restrictions, too many elbows, or too many equivalent feet of vent/intake air pipe. Check for dirt/debris on blower wheel. **Insure vent termination restrictor was not installed if it was not required.** See 5th bulleted item above.

- Flue gas temperature in blower assembly is excessive, pressure switch circuit is open due to vent temperature limit switch activating (see wiring diagram page 7). Determine cause - flue baffle/restrictor missing/damaged or not installed correctly & make repairs.

Defective vent temperature limit switch; this is a normally closed switch that opens its contacts on a rise in temperature. Turn off power and disconnect wires to the vent temperature switch. With the switch at room temperature (77 °F), check for continuity between the two wiring terminals on switch with an ohm meter. If switch contacts are open at room temperature - replace the switch.

INTELLI-VENT TROUBLESHOOTING GUIDE

ERROR CODE 5 - IGNITOR FAILURE

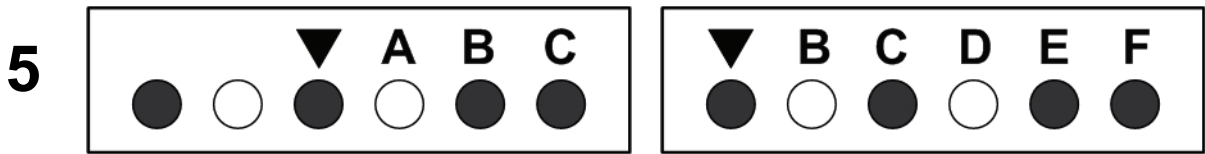

The Intelli-Vent™ control has detected an open ignitor circuit.

Check / Repair:

- Check all wiring to the hot surface ignitor.
- Check 5 pin Molex ignitor assembly plug and receptacle on the Intelli-Vent™ body for a good connection. Repair or replace parts if necessary.
- Check resistance of ignitor with an ohm meter between pin 1 and 2 on the ignitor assembly plug. Replace ignitor if resistance is not within 11.5 and 18.8 ohms.
- If above checks are good and ignitor resistance is within specification - replace the Intelli-Vent™ control.

ERROR CODE 6 - IGNITION / FLAME FAILURE

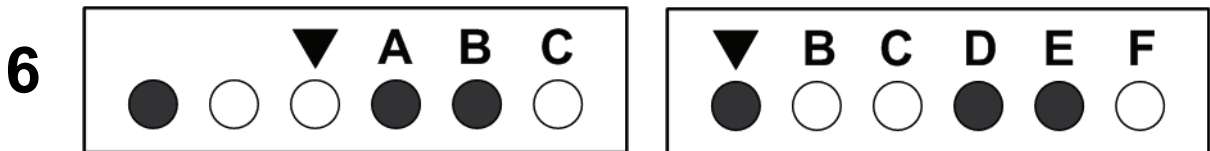

The water heater has reached the maximum number of retries or recycles and is currently locked out for one hour. Cycle the power to the water heater off and on to reset.

Check / Repair:

- Gas supply is off or too low of pressure to operate.
- Insure manifold gas pressure is present and within requirement.
- Insure the flame sensor is making good contact with the burner flame. See the Ignition and Flame Failure bulletin on page 16 and the burner check on page 18.
- Insure the flame sensor is clean - use steel wool to clean sensor.
- Insure **flue restrictor** (on models so equipped - see page 19) and flue baffle are installed properly. Flue restrictor must be flush on top of flue pipe. A dislodged or missing flue restrictor/baffle can cause excessive air turbulence in the combustion chamber - sweeping all gas away from ignitor (no ignition) or the flame away from the sensor (short cycling burner).
- Insure **vent termination restrictor** (see product notification sheets at end of this publication) is installed when required.
- Insure the ignitor is positioned correctly for consistent ignition.
- Low voltage to the water heater. Should be 115 - 125 VAC.

INTELLI-VENT TROUBLESHOOTING GUIDE

ERROR CODES - 7, 8, 9 - INTERNAL CONTROL FAILURES

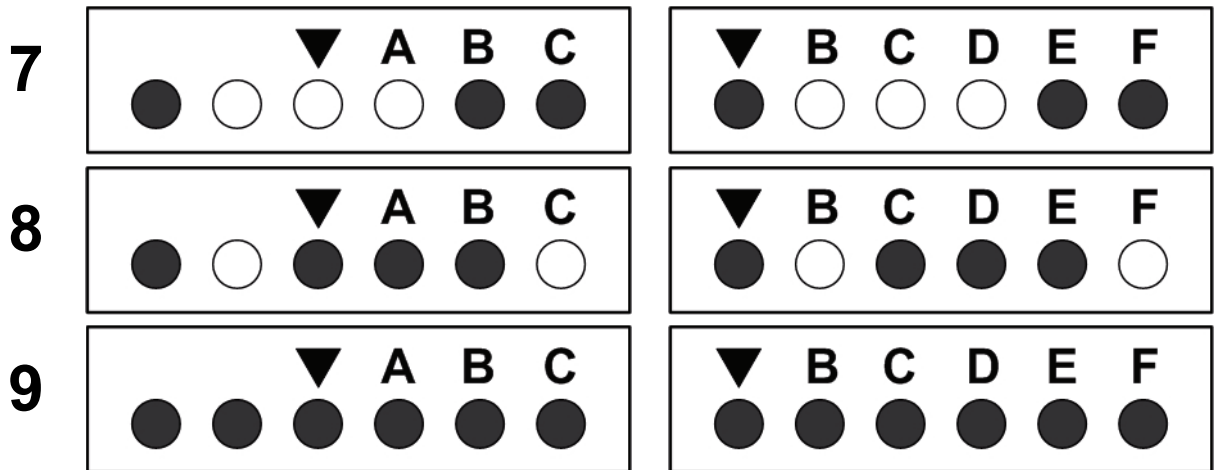

Self diagnostic tests have found a problem with the gas valve driver circuit, internal microprocessor, or the internal circuits.

Check / Repair:

- Turn the power off for 10-20 seconds then on again to clear these error codes.
- If any of these error codes persist or cannot be cleared - replace the Intelli-Vent™ control.

ERROR CODE 10 - FLAME SENSED OUT OF SEQUENCE

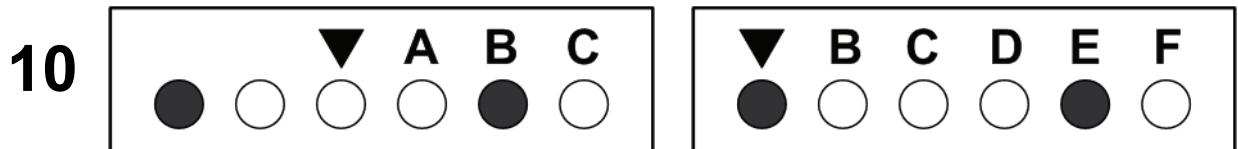

Flame signal has been sensed out of proper sequence.

Check / Repair:

- Insure flame sensor ceramic insulator is not cracked - replace ignitor assembly if defective.
- Turn the power off for 10-20 seconds and then on again to clear this error code.
- Replace the Intelli-Vent™ control if this error code persists.

INTELLI-VENT TROUBLESHOOTING GUIDE

ERROR CODE 11 - HIGH TEMPERATURE CUTOFF (ECO) ACTIVATED

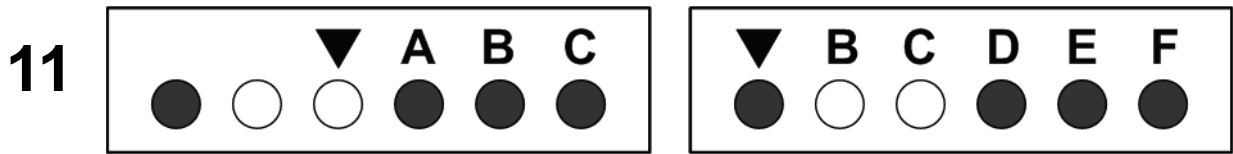

Water temperature in the tank exceeded 195°F and activated the ECO.

Check / Repair:

- Turn the power off for 10-20 seconds and then on again to clear this error code.
- Residential control - replace the control if the error code cannot be cleared.
- Commercial control - cool water temperature below 120°F, cycle power off and on to reset control. Replace the control if the error code persists.

ERROR CODE 12 - TEMPERATURE ADJUST BUTTONS STUCK CLOSED

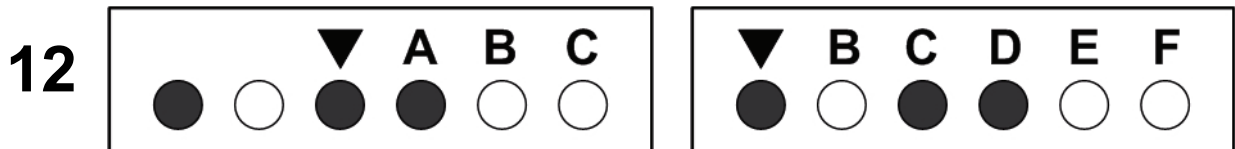

The self diagnostic check detected a temperature adjust button stuck closed.

Check / Repair:

- Make sure no objects are leaning against the front of the control.
- Lightly press and release each of the buttons once.
- If the above actions do not clear the error, the control will continue to regulate water temperature at the last setting, but you will not be able to change settings unless you replace the Intelli-Vent™ control.

ERROR CODE 13 - TEMPERATURE PROBE OPEN OR SHORTED

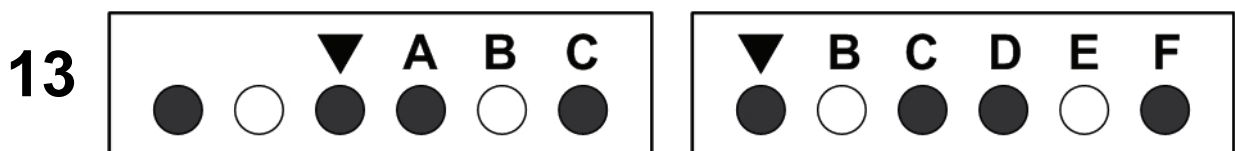

The self diagnostic test has detected the water temperature sensor (thermistor) is either open or short circuited.

Check / Repair:

- Turn the power off for 10-20 seconds then on again to clear this error code.
- This part of the control cannot be replaced or serviced. If the error code cannot be cleared, the Intelli-Vent™ control must be replaced.

INTELLI-VENT TROUBLESHOOTING GUIDE

ERROR CODE 14 - RESISTOR WIRE OPEN OR SHORTED

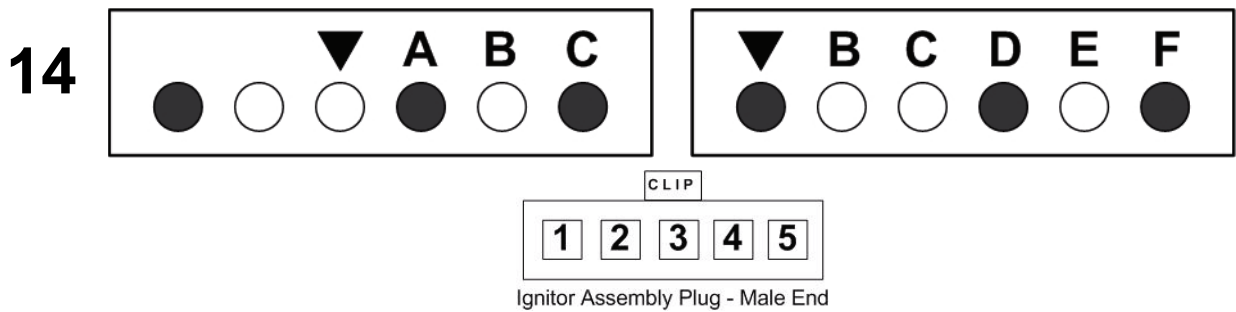

The self-diagnostic test found a problem with the black resistor wire on the ignitor assembly plug; the resistor wire is open or shorted. (see 6)

Check / Repair:

- Insure the black resistor wire is not cut, missing, and is installed between pins 3 & 4 of the ignitor assembly plug. Replace ignitor assembly if damaged or defective.
- Unplug the ignitor assembly plug from the control. Check the resistance of the black resistor wire between pins 3 & 4 with an ohm meter.
 - A If the reading taken is less than 2000 or more than 1.7 million ohms, replace the ignitor assembly.
 - B If the reading taken is between 2000 and 1.7 million ohms, replace the Intelli-Vent™ control.

ERROR CODE 15 - RESISTOR WIRE RESISTANCE OUT OF TOLERANCE

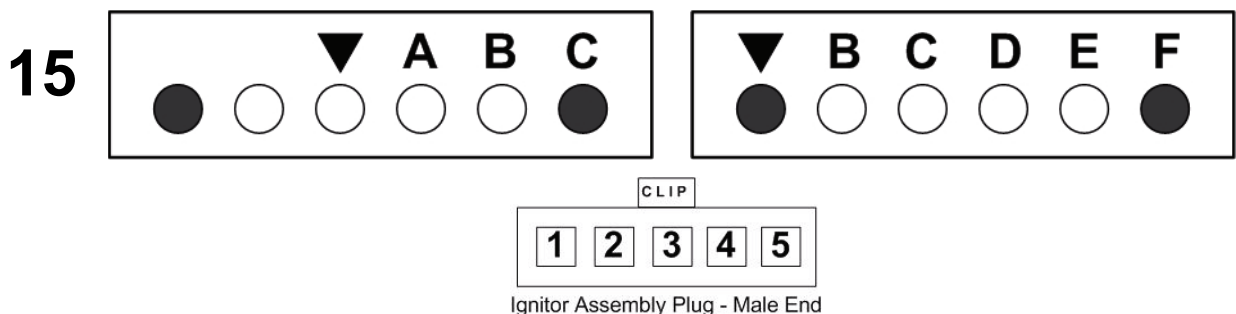

The self-diagnostic test determined the resistance of the black resistor wire on the ignitor assembly plug is not within tolerance. (see 6)

Check / Repair:

- Unplug the ignitor assembly plug from the control. Check the resistance of the black resistor wire between pins 3 & 4 with an ohm meter.
 - A If the reading taken is more than 50,000 ohms replace the ignitor assembly.
 - B If the reading taken is less than 50,000 ohms replace the Intelli-Vent™ control.

INTELLI-VENT TROUBLESHOOTING GUIDE

TECHNICAL BULLETIN - IGNITION AND FLAME FAILURE A-022-04 & S-021-04 COMBINED

This technical bulletin has been prepared to help diagnose and repair ignition and flame failure problems with White Rodgers Intelli-Vent equipped water heaters. Procedures to verify correct **flame sensor alignment, burner assembly condition, and flue restrictor/baffle position** are outlined in this bulletin. These procedures should help to identify and repair most ignition and flame failure problems.

Always verify an adequate supply of fuel gas (manifold gas pressure) and combustion air when experiencing ignition or flame failure.

Procedures for verifying an adequate supply of fuel gas and combustion air are detailed in the residential gas service handbook (A. O. Smith part number TC-049 R3, State Water Heaters part number STC-080) available through your local A. O. Smith or State Water Heaters sales representative or as free download from the web sites:

www.aosmithwaterheaters.com
www.statewaterheaters.com

If it is determined there is not a sufficient supply of combustion air or fuel gas, resolve these problems first. The test procedures outlined in this technical bulletin presume there is an adequate supply of both fuel gas and combustion air.

FLAME SENSOR ALIGNMENT

(Intelli-Vent™ equipped - standard recovery - 40 & 50 gallon residential water heaters)

The lower lip or edge of a low NOx burner extends out further than it does on a standard burner. Flame sensor gap and elevation are measured from the lower lip on low NOx burners and from the top lip on standard burners as illustrated on the following page.

The A. O. Smith Water Heater specifications given here are for standard recovery residential power vent and power direct vent 40 and 50 gallon models. GPSH 40, GPSH 50, GPDH 40, GPDH 50. Call the **A. O. Smith Water Heaters technical information center (800 527-1953)** for information on other models.

The State Water Heater specifications here are for standard recovery residential power vent and power direct vent 40 and 50 gallon models. PR6 40 & 50 XCVIT (natural) or CCVIT (propane), PR6 40 & 50 XBPDT (natural) or CBPDT (propane). Call the **State Water Heaters technical information center (800 365-0577)** for information on other models.

A. O. Smith	GAP		ELEVATION	
	NATURAL GAS	PROPANE GAS	NATURAL GAS	PROPANE GAS
GPSH 40 & 50	0.19"	0.25"	0.34"	0.13"
GPDH 40 & 50	0.13"	0.13"	0.40"	0.40"

State	GAP		ELEVATION	
	NATURAL GAS	PROPANE GAS	NATURAL GAS	PROPANE GAS
PR6 40 & 50 X/C CVIT	0.19"	0.25"	0.34"	0.13"
PR6 40 & 50 X/C BPDT	0.13"	0.13"	0.40"	0.40"

INTELLI-VENT TROUBLESHOOTING GUIDE

FLAME SENSOR ALIGNMENT (CONT)

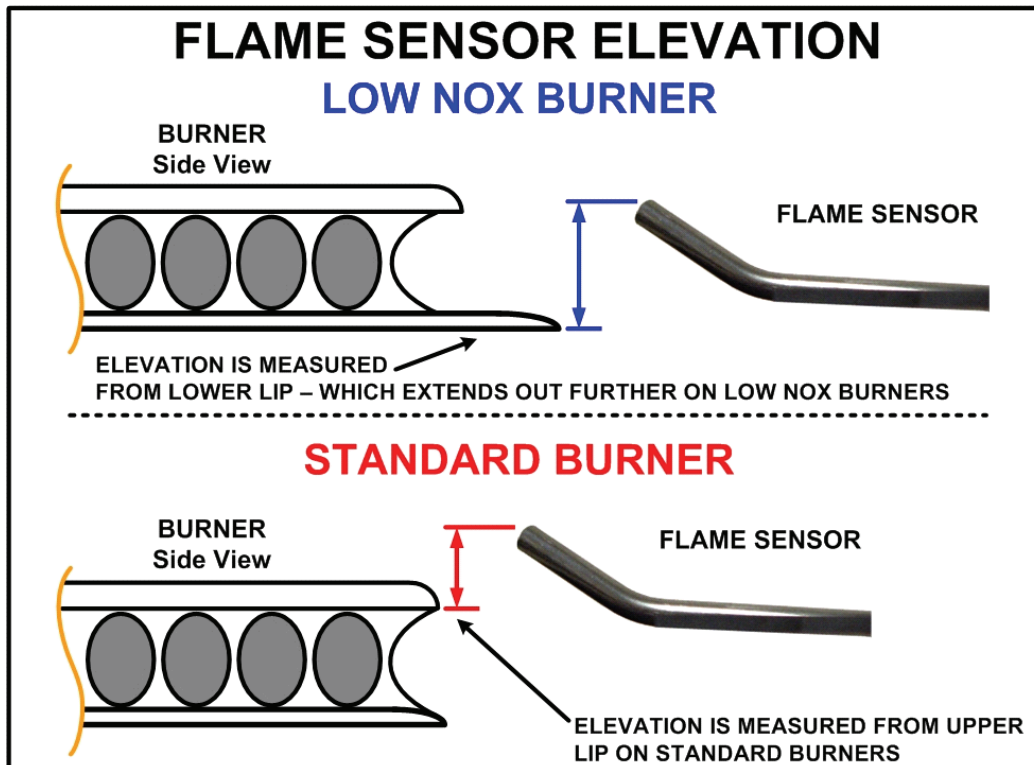
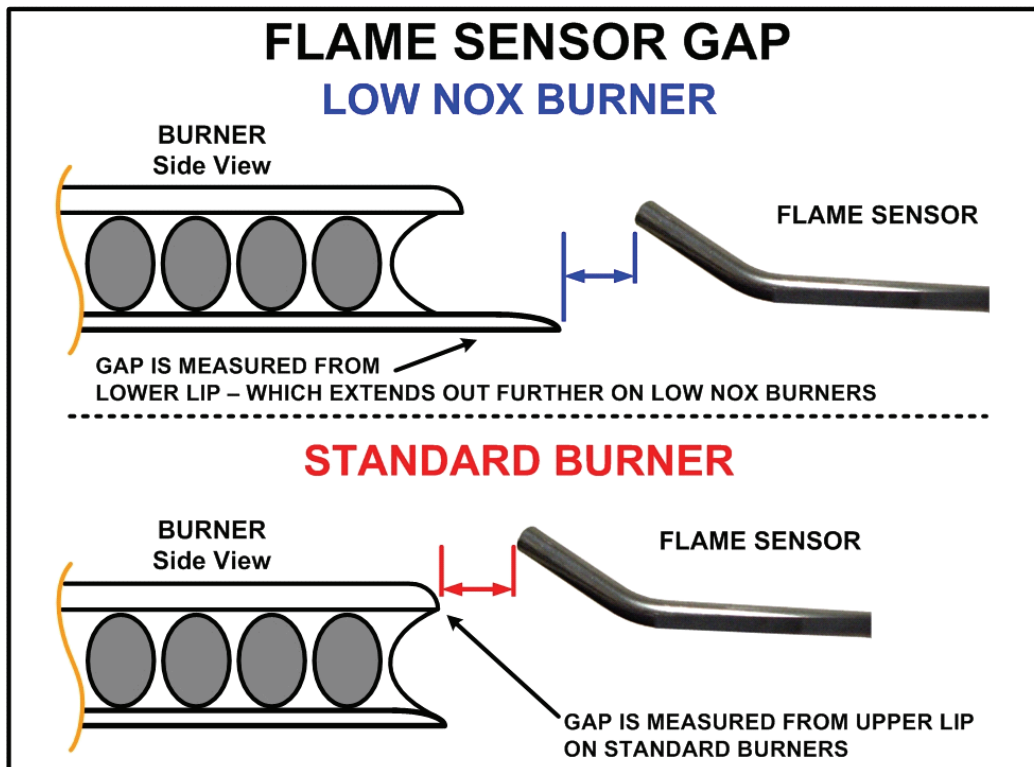

INTELLI-VENT TROUBLESHOOTING GUIDE

BURNER CHECK LIST

REMOVE BURNER TO PERFORM THE FOLLOWING TESTS

- 1 Burner mounting screws. Check the two mounting screws that hold the burner head to the main burner tube. These screws being loose can cause poor burner grounding and diminished or lost flame sensing current which leads to burner short cycling and lockout.?
- 2 Ignitor assembly plug connection. Check the 5 pin Molex plug and the female receptacle in the control body to insure all conductors are present and making good contact. Wiggle both Molex plugs at the control body to check for poor connections if the Intelli-Vent control is not responding for any reason.
- 3 Ignitor assembly wires. Check the three wires between the ignitor assembly and the Intelli-Vent control. Insure these wires are not cut or damaged. Replace the Ignitor assembly if the wiring is damaged.
- 4 Ignitor assembly ceramic insulators. Make a close visual inspection of the ignitor assembly insulators. Insure the two ceramic insulators for the ignitor and flame sensor are not chipped or cracked. Replace the ignitor assembly if these insulators are damaged or defective.
- 5 Ignitor resistance test. Check the ignitor resistance with an ohm meter set on a low scale. Ignitor resistance should be between 11.5 and 18.8 ohms. If the resistance of the ignitor is not within this range, replace the ignitor. Worn or damaged ignitors can cause ignition failure and control lockout after three failed ignition attempts.
- 6 Flame sensor condition. Insure the flame sensor is free of rust and corrosion; clean the sensor with steel wool. Sand cloth can be used; be sure to clean off any residue left by the sand cloth. Rust or corrosion on a flame sensor will cause diminished or lost flame sensing current which leads to burner short cycling and control lockout after three failed ignition attempts.
- 7 Flame sensor (ignitor) alignment.?Insure the flame sensor is aligned with the burner according to the specifications on the previous page of this bulletin. A misaligned flame sensor can lead to diminished or lost flame sensing current which causes burner short cycling and control lockout after three failed ignition attempts. If the flame sensor is aligned properly the ignitor should be positioned correctly also since both are fixed to a common assembly.
- 8 Low NOx screen – clearance. On low NOx models, insure the low NOx screen is not touching either the ignitor or the flame sensor when installed inside the combustion chamber. This screen touching the flame sensor could cause a false flame sensing signal and control lockout.

INTELLI-VENT TROUBLESHOOTING GUIDE

FLUE BAFFLE & FLUE RESTRICTOR CHECK



Flue baffle assembly shown to the left. Insure this is assembled and installed properly. This can become dislodged during transport.

Always check the flue baffle assembly if the water heater has been laid on its side during transport.

Some power vent residential models are equipped with flue restrictors in addition to the flue baffles installed on all models. The flue restrictor and flue baffle are engineered to precisely regulate the flow of flue gases through the flue pipe. This maximizes the amount of heat conducted into the water through the walls of the flue pipe. The flue restrictor and baffle will also affect the velocity of air being drawn into and through the combustion chamber.

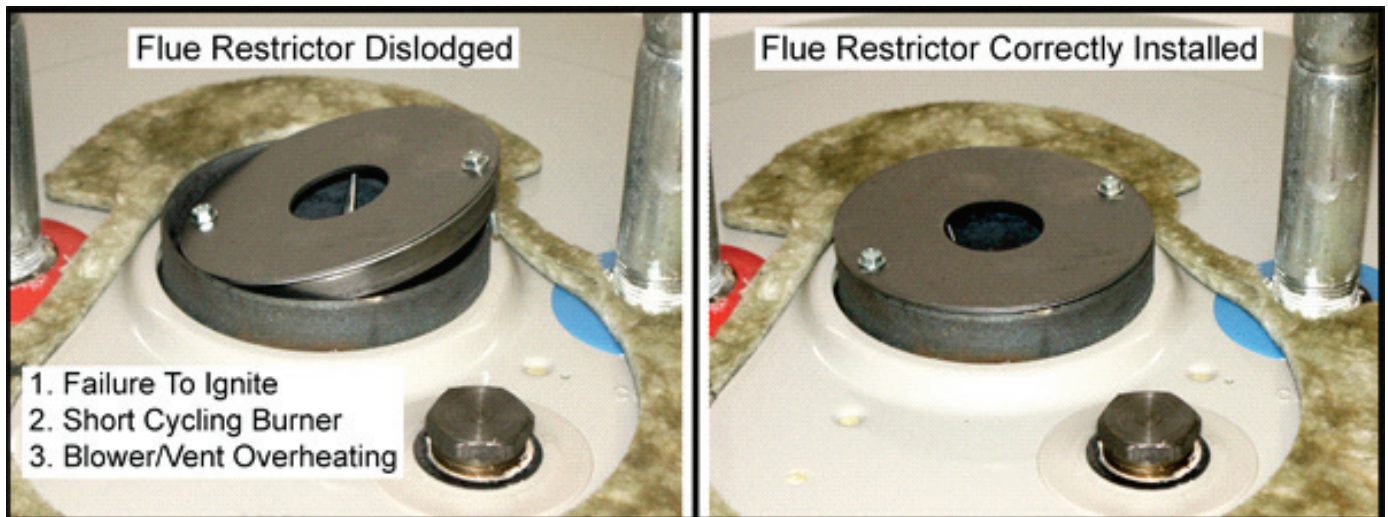

If the flue restrictor is dislodged as shown in the left illustration above, the velocity of air flowing through the combustion chamber will increase. This can cause air turbulence inside the combustion chamber that leads to:

- 1 Fuel gas being swept away from the ignitor leading to ignition failure (failure to ignite). The Intelli-Vent control would lockout after 3 failed attempts and display error code 6.
- 2 Ignition occurs but the air turbulence blows the flame away from the flame sensor causing burner short cycling. The Intelli-Vent control would lockout after 3 failed attempts and display error code 6.

A dislodged flue restrictor or baffle can also allow too much heat to flow into the combustion blower and vent system leading to:

- 1 Vent temperature limit switch contacts opening during the heating cycle, preventing the thermostat from satisfying. The Intelli-Vent control closes the gas valve immediately if this switch activates.
- 2 Heat damage to the combustion blower and/or vent system components.

The outer and inner combustion chamber access covers and the fiberglass insulation between the outer jacket and the combustion chamber must also be installed correctly. If not installed properly this could also cause excessive air turbulence inside the combustion chamber. Insure these covers are installed correctly and the fiber glass insulation is not removed or tucked/pushed away from these openings when servicing.

Insure the flue baffle, flue restrictor, combustion chamber access covers, and fiber glass insulation between the outer jacket and combustion chamber are all installed properly to minimize ignition and flame failure conditions.

INTELLI-VENT TROUBLESHOOTING GUIDE

TECHNICAL BULLETIN - AIR PRESSURE SWITCHES A-023-04 & S-024-04 COMBINED

Air pressure switches are used on all fan assisted gas fired water heaters, residential and commercial. If the water heater was factory equipped with a combustion blower or inducer fan, by design the blower must running during the heating cycle.

Air pressure switches are used to provide verification, or prove electrically, that the blower is running and the vent and/or combustion air piping is not blocked or restricted.

The ignition control on these fan assisted boilers and water heaters senses when the “air pressure switch circuit” is open or closed. There is at least one air pressure switch in this circuit that has normally open contacts on all models (see page 5). As the blower starts and comes up to speed the normally open contacts on this air pressure switch will close in response to changes in vent system pressure.

At the beginning of a heating cycle the ignition control will check if the air pressure switch circuit is open before the control energizes the blower motor.

The ignition control will check the air pressure switch circuit a second time to insure it is closed after the blower is energized.

The ignition control then monitors this circuit during the heating cycle to insure the circuit remains closed. If this circuit opens (even for a split second) during the heating cycle; the control will close the gas valve immediately to insure safe operation.

In this way an ignition control can perform three critical diagnostic checks using a single air pressure switch:

- 1 Verify the normally open air pressure switch contacts are not stuck closed or jumpered.
- 2 Verify the combustion blower or inducer fan is running.
- 3 Verify the vent and/or combustion air piping remain free of restrictions.

Pressure switch construction, operation, testing, the various types of pressure switches and their wiring are explained in this bulletin.

INTELLI-VENT TROUBLESHOOTING GUIDE

AIR PRESSURE SWITCH CONSTRUCTION

The switch below has normally open switch contacts that close on a fall in pressure.

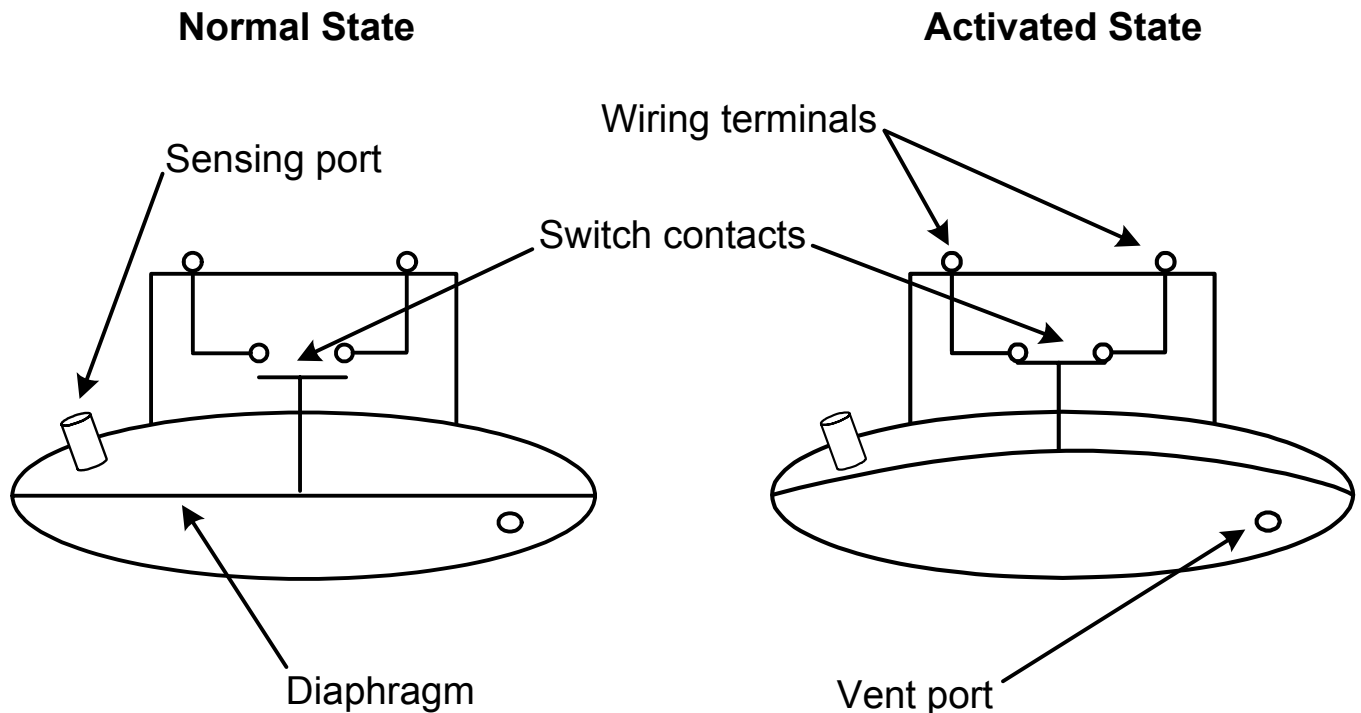

AIR PRESSURE SWITCH OPERATION

Air pressure switches activate in response to changes in air pressure sensed through a plastic tube attached to a sensing port on the water vent system and/or blower housing.

The diaphragm divides the body of the switch into two air chambers. The air chamber the sensing port is attached to is sealed. The other chamber is vented to the atmosphere which allows the diaphragm to move up and down. There is linkage that attaches the switch contacts to the diaphragm so that when the diaphragm moves the contacts are activated.

The term "activate" means to change state. If the contacts are normally open, activating the contacts will cause them to close. If the contacts are normally closed, activating the contacts will cause them to open.

Service Note:

Because one of the two air chambers is vented to the atmosphere, the ambient air pressure in the installed space is critical. If the ambient air pressure is below atmospheric (outdoor) air pressure, it will pull on the pressure switch diaphragm. If the ambient air pressure is above atmospheric it will push on the pressure switch diaphragm. In either condition the pressure switch will not operate as designed if the pressure imbalance is severe enough. Correcting an air pressure imbalance between the installation space and the outdoors can be achieved by providing adequate make up air openings.

Direct vent installations will not eliminate this potential problem.

INTELLI-VENT TROUBLESHOOTING GUIDE

AIR PRESSURE SWITCHES - DIFFERENT TYPES

SWITCH CONTACTS	SWITCH ACTION
Normally Open = NO	Close on a rise in pressure
	Close on a fall in pressure
Normally Closed = NC	Open on a rise in pressure
	Open on a fall in pressure

The switches shown here are all SPST switches. SPST = single pole, single throw. Power Vent and Power Direct Vent residential products use the first type shown below.

Normal State

Activated State

Normally open contacts, close on a fall in pressure.

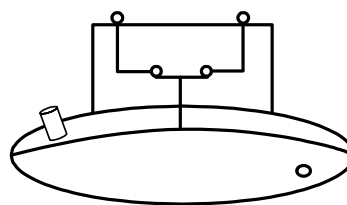
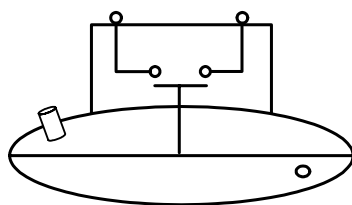

Normally closed contacts, open on a fall in pressure.

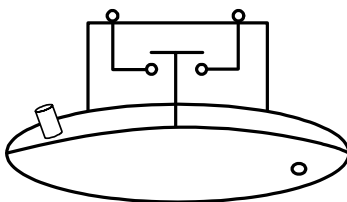
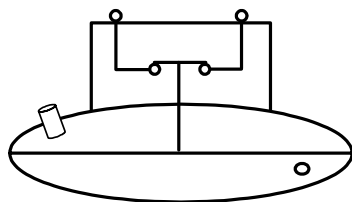

Normally open contacts, close on a rise in pressure.

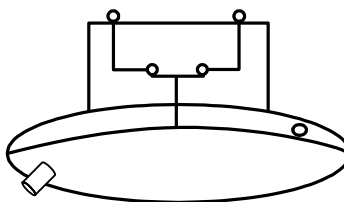
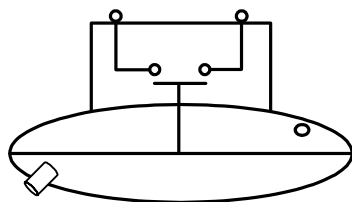

Normally closed contacts, open on a rise in pressure.

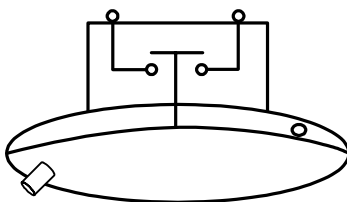
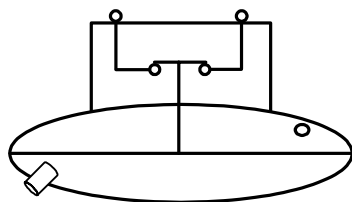

INTELLI-VENT TROUBLESHOOTING GUIDE

AIR PRESSURE SWITCH TESTING



Continuity test with ohm meter



Taking an air pressure reading

To test the performance of an air pressure switch you must know the design activation point. This will be a given pressure value, either negative (in a vacuum) or a positive pressure. Contact the technical information center for this information or to locate a service handbook for the product you are working on. **A. O. Smith Water Heaters; 800 527-1953. State Water Heaters; 800 365-0577.** Have the complete model, serial, and series number on hand.

Testing air pressure switch performance requires a digital or incline manometer that will read pressures at the expected activation point to within 1/100th of an inch of water column ("W.C.") at times. **Digital manometers** are typically less expensive and quicker to use than incline manometers. Manufacturers include Dwyer, UEI, and Bacharach. **A good range of operation would be -15.00" W.C. to +15.00" W.C. Must be sensitive to 1/100th "W.C..**

With the sensing tube removed from the vent system sensing port, attach the manometer to the port, start the water heater and when the blower comes up to speed record the pressure reading. If the pressure reading does not reach the activation point for the pressure switch, the vent system must be checked for restrictions, too many elbows, or too many equivalent feet of piping. Consult the owners manual for complete venting requirements. Inspect/clean the blower as necessary.

The state of the air pressure switch contacts can be checked with an ohm meter for continuity.

A normal state test would be done with the power off and the wires to the switch removed. If the switch is a normally open switch and the continuity test showed continuity through the contacts; the switch is defective and must be replaced. A normally closed switch would be defective if it showed no continuity under these conditions.

An operational test would be performed during blower operation with the wires to the air pressure switch removed and the sensing tube attached at both ends. With an ohm meter check continuity between the two wiring terminals on the pressure switch after the blower comes up to speed. If the pressure reading taken previously is at or beyond the activation point for the pressure switch and the pressure switch contacts do not activate, the pressure switch is defective and must be replaced.

INTELLI-VENT TROUBLESHOOTING GUIDE

AIR PRESSURE SWITCH CIRCUITS

Air Pressure Switch Circuit - Residential Power Vent/Power Direct Vent

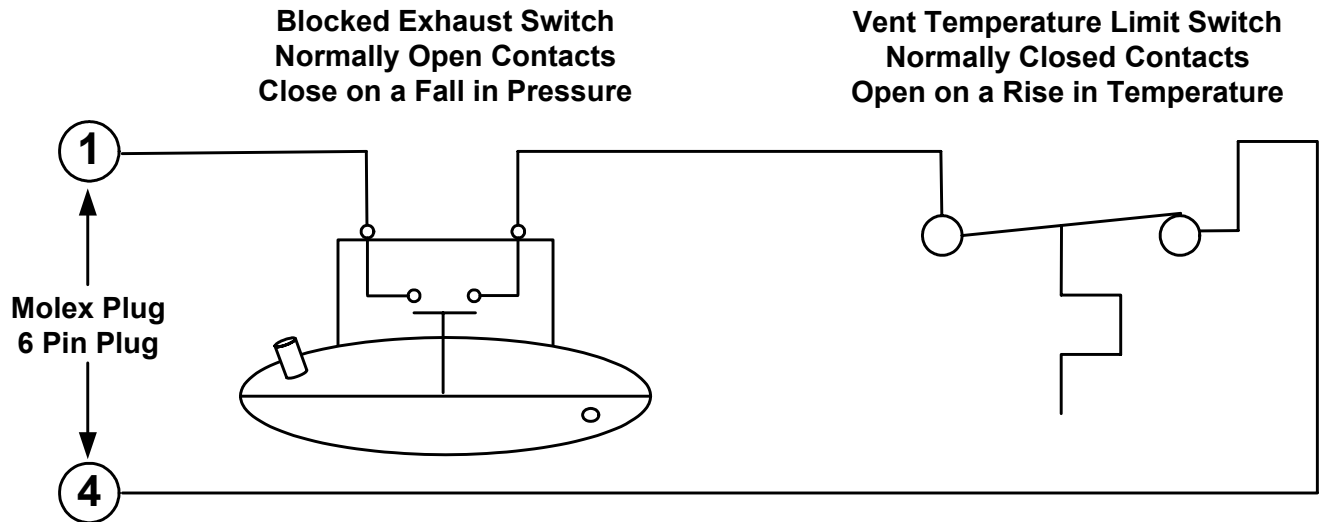

No.: ARGPN0305N
Date: March 18, 2005

Vent Termination Restrictor Usage for 40,000 Btu Power Vent Models

This bulletin will simplify vent termination restrictor usage for the 40,000 Btu power vent models and allowable venting distances.

Power vent models, 40,000 Btu, manufactured prior to November 2004 (serial number K04) are shipped with a vent kit that includes a 2" restrictor (1 3/4" inside opening) and 2" tee. These kits are used for 2' vent installations up to 33 equivalent (*not* to exceed 33 feet) feet of vent pipe (2" restrictor is not needed if the vent run is longer than 33 equivalent feet) and a 3" restrictor and 45 degree elbow for 3" vent installations of any vent length (up to the maximum distance of 38 equivalent feet). These restrictors are to be installed in the vent termination tee or elbow if the vent is less than distances listed above.

In November 2004 (serial number L04), the 2" restrictor (in the old vent kit) was replaced with a new 2" restrictor (1 1/4" inside opening) and the 3" restrictor was dropped from the kit. The venting distance requiring the use of the restrictor was reduced to 20 feet or less with this change. This means that if the vent distance is greater than 20 feet the restrictor is not needed. The series numbers (100 & 101) did not change with the revision to these kits. However, the termination tee that we have been buying/using, since November 2004 has the 2" restrictor installed in the tee. If the vent length is more than 20 feet the 2" restrictor is not needed and the restrictor must be removed from the tee or the pressure switch will not make and the heater will not operate.

The restrictor's affect is resistance or restriction and on short vent runs this helps maintain energy factors. If used on longer vent runs (2" pipe over 20 feet), it adds too much restriction and the pressure switch will not let the heater operate.

With all of that said, we are about to switch to a new series of power vent models (series 102 & 103) that will not use a restrictor in the vent termination. You should start seeing this new series of power vent models by month end, as inventory levels begin to diminish. The new heaters will have different blower, baffle and burner assembly (no NOx screen on the burner).

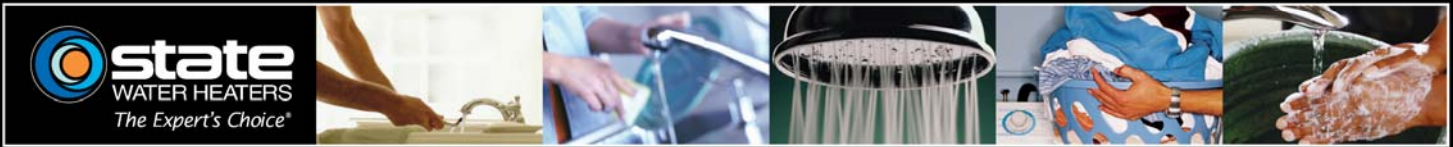

500 LINDAHL PARKWAY • ASHLAND CITY, TN 37015 • 1-800-365-8170 • www.statewaterheaters.com

Product Notification

No.: S425

Date: 10/21/04

Vent Termination Restrictor Usage for 40,000 Btu Power Vent Models

This bulletin will simplify vent termination restrictor usage for the 40,000 Btu power vent models and allowable venting distances.

Power vent models, 40,000 Btu, manufactured prior to November 2004 (serial number K04) are shipped with a vent kit that includes a 2" restrictor (1 $\frac{3}{4}$ " inside opening) and 2" tee. These kits are used for 2' vent installations up to 33 equivalent (*not* to exceed 33 feet) feet of vent pipe (2" restrictor is not needed if the vent run is longer than 33 equivalent feet) and a 3" restrictor and 45 degree elbow for 3" vent installations of any vent length (up to the maximum distance of 38 equivalent feet). These restrictors are to be installed in the vent termination tee or elbow if the vent is less than distances listed above.

In November 2004 (serial number L04), the 2" restrictor (in the old vent kit) was replaced with a new 2" restrictor (1 $\frac{1}{4}$ " inside opening) and the 3" restrictor was dropped from the kit. The venting distance requiring the use of the restrictor was reduced to 20 feet or less with this change. This means that if the vent distance is greater than 20 feet the restrictor is not needed. The model numbers did not change with the revision to these kits. However, the termination tee that we have been buying/using, since November 2004 has the 2" restrictor installed in the tee. If the vent length is more than 20 feet the 2" restrictor is not needed and the restrictor must be removed from the tee or the pressure switch will not allow the heater to operate.



The restrictor's affect is resistance or restriction and on short vent runs this helps maintain energy factors. If used on longer vent runs (2" pipe over 20 feet), it adds too much restriction and the pressure switch will not let the heater operate.

With all of that said, we are about to switch to a new series of power vent models (series 102 & 103) that will not use a restrictor in the vent termination. You should start seeing this new series of power vent models by month end, as inventory levels begin to diminish. The new heaters will have different blower, baffle and burner assembly (no NOx screen on the burner).

Additional copies are available from the
Ashland City Advertising Department

**Prepared by the A. O. Smith/State Water Heater
Technical Training Department
Ashland City, Tennessee**

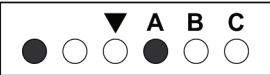
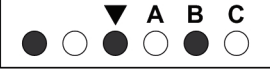
TB-A028-06 - A. O. SMITH - FVIR INTELLI-VENT TROUBLESHOOTING CHART

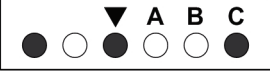
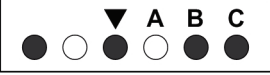
#	LED STATUS	PROBLEM	SOLUTION
1		Inadequate or no earth ground sensed by the Intelli-Vent™ control.	<ol style="list-style-type: none"> 1 Ensure the wall outlet is properly grounded. 2 Ensure all ground connections/wires on the water heater are secure.
2		Power supply to Intelli-Vent™ control has reversed polarity.	<ol style="list-style-type: none"> 1 Ensure the wall outlet is properly wired. 2 Ensure all internal 120 VAC wiring connections and wiring harness have no reversed wires. 120 VAC "hot" wire must connect to the on/off switch.
3		<p>Pressure switch circuit remaining closed for more than 5 seconds after heating cycle begins.</p> <p>Blower does not start.</p> <p>Service Note: Secure power - disconnect one wire from the air pressure switch or the vent temperature limit switch. Turn power back on - blower should start.</p>	<ol style="list-style-type: none"> 1 Ensure air pressure switch circuit wiring is correct and the air pressure switch is not jumpered. 2 Secure power to water heater, check continuity of air pressure switch contacts with wires disconnected. <ul style="list-style-type: none"> A If pressure switch contacts show continuity (closed circuit) replace the pressure switch. B If pressure switch contacts are open and all wiring is correct - turn the power off for 10-20 seconds then on again to clear the error code - if the error code persists replace the Intelli-Vent™ control.
4		<p>Pressure switch circuit remains open longer than 5 seconds after the blower is energized.</p> <p>Blower may run continuously in this condition.</p> <p>Service Note: To learn more about performing Air Pressure Switch tests visit our web site www.hotwater.com to download technical bulletin TB-A023-06 Air Pressure Switches.</p>	<ol style="list-style-type: none"> 1 Ensure the blower is running - check for 120 VAC to the blower when the heating cycle begins, check the wiring. If the control does not energize the blower - replace the Intelli-Vent™ control. If the blower fails to start when energized - replace the blower assembly. 2 Ensure the air pressure switch sensing tube is properly connected - not kinked or damaged. 3 Check continuity of vent temperature limit switch - replace switch if contacts remain open under 160°F. 4 Ensure the correct size of vent pipe (2", 3", 4") was used per the installation manual for vent length. Ensure maximum number of elbows or equivalent feet of vent pipe has not exceeded maximum limits. 5 Ensure there are no obstructions in the vent pipe. 6 Check air pressure switch performance - check pressure with a digital manometer - check continuity of contacts. (see service note in left column) If the switch proves defective - replace the air pressure switch and/or the blower assembly as required. 7 If air pressure switch performance test results prove the air pressure switch is working properly and error code 4 persists - replace the Intelli-Vent™ control.
5		<p>The Intelli-Vent™ control has detected an open ignitor circuit.</p> <p>Service Note: Ignitors are wearing parts; the resistance (ohms) of a hot surface ignitor will increase over time. If the resistance at room temperature is near 18.8 ohms - consider replacing the ignitor as a preventative measure.</p>	<ol style="list-style-type: none"> 1 Check wiring to the hot surface ignitor - replace ignitor assembly if wiring is damaged or worn. 2 Check ignitor assembly plug and the socket on the Intelli-Vent™ body for good connection. Replace ignitor assembly and/or control if necessary. 3 Check resistance of ignitor at room temperature (77°F) at the plug end. Replace ignitor if resistance is not within 11.5 and 18.8 ohms at room temperature. 4 If results from the above tests were good and error code 5 persists - replace the Intelli-Vent™ control.

TB-A028-06 - A. O. SMITH - FVIR INTELLI-VENT TROUBLESHOOTING CHART

#	LED STATUS	PROBLEM	SOLUTION
6		<p>Ignition/flame failure.</p> <p>The water heater has reached the maximum number of retries and is currently locked out for one hour.</p> <p>Cycle the power to the water heater off and on to reset.</p> <p>Service Note: Igniters are wearing parts; the resistance (ohms) of a hot surface ignitor will increase over time. If the resistance at room temperature is near 18.8 ohms - consider replacing the ignitor as a preventative measure.</p>	<ol style="list-style-type: none"> 1 Gas supply is turned off - pressure too low. Ensure supply and manifold gas pressures are within requirements in the installation manual. Manifold gas pressure is non-adjustable if pressure is off by more than 0.3" W.C. replace the Intelli-Vent™ control. 2 Low supply voltage - should be 115 - 125 VAC. 3 Ensure flame sensor is making good contact with the burner flame, ensure flame is steady see #8 below. 4 Ensure the flame sensor is clean - use ultra fine steel wool or Scotch-Brite™ pad to clean flame sensor. 5 Ensure the hot surface ignitor is positioned to provide consistent ignition. 6 Check for any cracks in ignitor assembly ceramic insulators - replace ignitor assembly if damaged. 7 Check resistance of ignitor at room temperature (77°F) at the plug end. Replace ignitor if resistance is not within 11.5 and 18.8 ohms at room temperature. 8 Ensure the correct size of vent pipe (2", 3", 4") was used per installation manual for vent length. Using larger pipe than required may cause excessive air turbulence in the combustion chamber.
7 8 9		<p>Self diagnostic tests have found a problem with the gas valve driver circuit, internal microprocessor, or other internal circuits.</p>	<ol style="list-style-type: none"> 1 Turn the power off for 10-20 seconds then on again to clear these error codes. 2 If any of these error codes persist or cannot be cleared - replace the Intelli-Vent™ control.
10		<p>Flame signal has been sensed out of proper sequence.</p>	<ol style="list-style-type: none"> 1 Turn the power off for 10-20 seconds and then on again to clear this error code. 2 Replace the Intelli-Vent™ control if this error code persists.
11		<p>Water temperature in the tank has exceeded 195°F and has activated the ECO.</p>	<ol style="list-style-type: none"> 1 Turn the power off for 10-20 seconds then on again to clear this error code. 2 Replace the control if the error code persists.
12		<p>The self diagnostic check detected one or both of the temperature adjust buttons are stuck.</p>	<ol style="list-style-type: none"> 1 Press and release temperature adjust buttons. If the above action does not clear the error, the control will continue to regulate water temperature at the last setting. However, settings will no longer be adjustable - the control should be replaced.
13		<p>The self diagnostic test has detected the water temperature sensor (thermistor) is either open or shorted.</p>	<ol style="list-style-type: none"> 1 Turn the power off for 10-20 seconds then on again to clear this error code. 2 Replace the Intelli-Vent™ control if this error code persists.

TB-A028-06 - A. O. SMITH - FVIR INTELLI-VENT TROUBLESHOOTING CHART

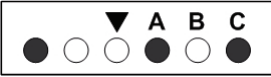
#	LED STATUS	PROBLEM	SOLUTION
14		<p>The self diagnostic test has detected the flammable vapor sensor is either open or shorted.</p> <p>The Intelli-Vent control is programed to lock-out and display this error code if the resistance value it senses from the FV sensor is below 5,000 ohms or above 1,700,000 ohms.</p> <p>Service Note: To perform this test the ohm meter used must be capable of reading up to 2,000,000 ohms.</p>	<ol style="list-style-type: none"> 1 Turn off power to the water heater. Ensure all FV sensor wiring, the ignitor assembly plug, and the ignitor assembly socket on the bottom of the Intelli-Vent™ control are making good contact. Repair or replace any worn/damaged components that are not making a good connection. 2 Restore power to the water heater - if the error code has cleared place the water heater back in operation and allow it to cycle several times to ensure the problem has been resolved. If the error code persists - continue to step 3 below. 3 Turn off power to the water heater. Remove the FV sensor from it's bracket on the base ring of the water heater and disconnect both wires to the sensor. Take a resistance reading between the two wiring terminals of the FV sensor and note the resistance value. <p>Service Note: Unless the ohm meter used has an auto-range feature the resistance should be checked twice. The first reading will be taken using an ohms scale above 1,700,000 ohms. The second reading is taken using an ohms scale just above 5,000 ohms.</p> <ol style="list-style-type: none"> 4 If resistance of the FV sensor is lower than 5,000 ohms - replace the FV sensor. 5 If resistance of the FV sensor is above 1,700,000 ohms - replace the FV sensor. 6 If the resistance of the FV sensor is above 5,000 ohms and lower than 1,700,000 ohms and all the above steps have been performed - ensure the wiring and plug between the sensor and the Intelli-Vent™ control are not damaged or worn - replace the ignitor assembly if the wiring and/or plug are damaged/worn. <p>If the wiring and plug are in good condition - replace the Intelli-Vent™ control valve</p>

Flammable Vapor Sensor Location / Testing

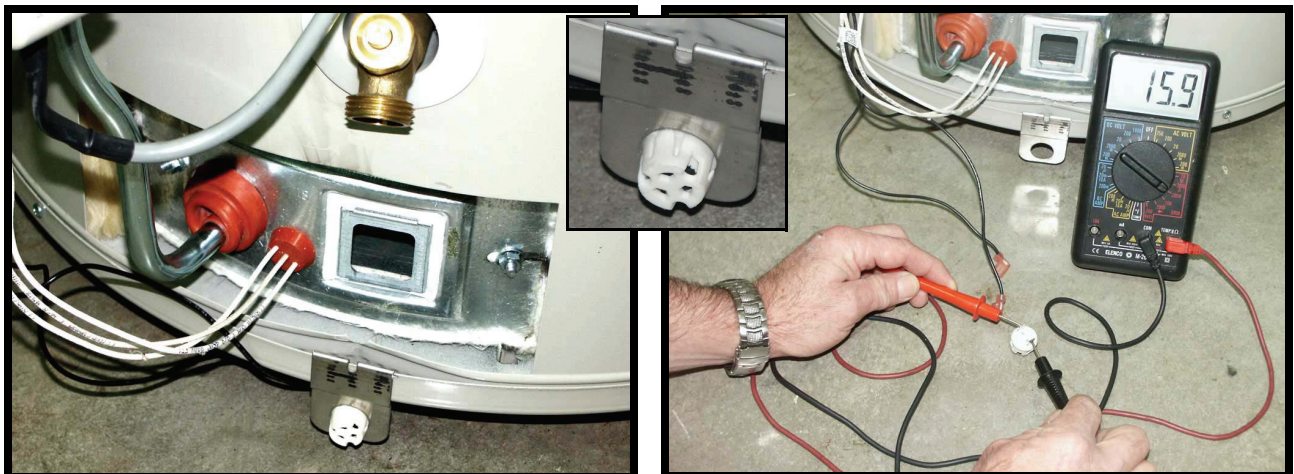

TB-A028-06 - A. O. SMITH - FVIR INTELLI-VENT TROUBLESHOOTING CHART

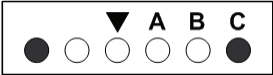
#	LED STATUS	PROBLEM	SOLUTION
15		<p>The self diagnostic test has detected the presence of flammable vapors.</p> <p>The Intelli-Vent control is programmed to lock-out and display this error code if the resistance value it senses from the FV sensor is above 70,000 ohms but remains below 1,700,000 ohms.</p> <p>The Intelli-Vent control is in a hard lock-out condition that cannot be reset by cycling power to the water heater. See the instructions below for the reset procedure.</p>	<ol style="list-style-type: none"> 1 Turn off power to the water heater. Carefully check the surrounding area for any substances such as gasoline, paint, paint thinners, or cleaners that could emit flammable vapors. Remove anything that can potentially emit flammable vapors from the area and store it properly in a different location. 2 Ensure power to the water heater is turned off. Remove the FV sensor from its bracket on the base ring of the water heater and disconnect both wires to the sensor. Take a resistance reading between the two wiring terminals of the FV sensor and note the resistance values. Perform this test once in the area by the water heater and a second time outdoors after allowing the sensor to acclimate to the outdoor atmosphere for 5 minutes. Service Note: These resistance readings should be taken using an ohm scale above 70,000 ohms. 3 If the resistance of the FV sensor is above 70,000 ohms during the indoor test only and the resistance reading taken in the outdoor atmosphere dropped below 70,000 ohms. Re-check the area surrounding the water heater for substances that could be emitting flammable vapors. Remove any such substances from the area and store them properly in a different location. Repeat step 2. 4 If the resistance of the FV sensor is above 70,000 ohms during the indoor and outdoor tests - replace the flammable vapor sensor. 5 If the resistance of the FV sensor was below 70,000 ohms during the indoor and outdoor tests and all the steps above have been performed - replace the Intelli-Vent™ control.

Flammable Vapors Sensed (FVS) Reset Procedure

After a flammable vapor lockout has been initiated, a manual reset must be performed to restore operation. The following should be done by a qualified service person after the hazard has been removed:

- 1 Manual reset is accomplished by first, turning off power to the water heater for 10 seconds.
- 2 Restore the power to the water heater.
- 3 Within 10 seconds of restoring power, press the two temperature adjust buttons simultaneously until the left (green) "Vacation" LED begins to blink (approx. 5 second delay). Once the Vacation LED begins to blink, release both buttons.
- 4 Again, within 10 seconds, press both temperature adjust buttons simultaneously until the Vacation LED is on steady (approx. 5 second delay).
- 5 Release the two buttons, the microcomputer will clear the FVS lock-out and normal operation will then be restored.

TB-A028-06 - A. O. SMITH - FVIR INTELLI-VENT TROUBLESHOOTING CHART

#	LED STATUS	PROBLEM	SOLUTION
16		<p>LDO (Lint, Dust, and Oil) lock-out condition.</p> <p>Air pressure switch circuit is opening repeatedly during one heating cycle. May be caused by the air pressure switch and/or the vent temperature limit switch (these two switches are wired together in a "series" circuit).</p>	<ol style="list-style-type: none"> 1 Check/clean intake air screen on the base ring of the water heater. 2 Check/clean the dilution air screen on the blower assembly. 3 Check/clean the flame arrestor - see the service note below. 4 Remove the blower assembly and check the flue baffle - ensure the flue baffle is in good condition and properly installed - reinstall as necessary and/or replace the flue baffle if worn or damaged. 5 Ensure water heater is not over-firing - check burner orifice size - ensure the correct orifice is installed - replace as necessary. 6 Ensure water heater is not over-firing - check manifold gas pressure - ensure manifold gas pressure is within 0.3" W.C. of the listed rating on the Intelli-Vent™ control valve. Manifold gas pressure is non-adjustable, if manifold gas pressure is off by more than 0.3" W.C. - replace the Intelli-Vent™ control. 7 Check the vent temperature limit switch - if it is determined that the vent temperature limit switch is opening its contacts at normal operating temperatures during the heating cycle - replace the vent temperature limit switch. <p>Service Note: the flame arrestor is accessible through the intake air opening in the base ring of the water heater with the intake air screen removed. Use a non-metallic household brush to clear away any lint or dust from the ceramic flame arrestor, then vacuum the surface of the flame arrestor and the base ring air chamber thoroughly with a household vacuum cleaner. A suitable vacuum hose attachment can be fabricated in the field using a short length of 1/2" PVC pipe with a short radius elbow on one end. Use tape to temporarily seal it to the vacuum hose.</p>

Additional Recommended Service Publications

- Power-Vent service manual - part number TC-048 R6 (revision 6 or later)
- Intelli-Vent™ service manual supplement - part number GTC-070 R3 (revision 3 or later)
- Air Pressure Switches technical bulletin - number TB-A023-06

Visit our web site at www.hotwater.com to download the above service manual and supplement. Revision numbers for these service publications are designated by R3, R4, R6, R7, etc. as a suffix to the part numbers IE: GTC-070 R4

A. O. Smith Training Department

Technical Bulletin TB-A023-06

Air Pressure Switches

This bulletin has been prepared to explain and illustrate the construction, operation, and testing procedures for various types of air pressure switches used on residential and commercial tank type water heaters.

Air pressure switches are used on all “fan assisted” gas fired water heaters in our product line. Air pressure switches are used to verify that operational conditions are being met; IE: the blower is running or the vent/combustion air piping length is not excessive or obstructed.

Air pressure switches are usually wired together with other switches into a “series” circuit (see page 8). The ignition control constantly monitors the “state” of the air pressure switch “circuit” - whether it is open or closed. There will always be at least one air pressure switch that has normally open contacts (see pages 7 & 8). As the blower starts and comes up to speed the normally open contacts of this switch should “activate” (contacts will close) in response to the pressure it senses – as long as there are no adverse operating conditions.

Normal Operating Sequence - Pressure Switch Circuit (Power-Vent, Power Direct-Vent, Cyclone, Master-Fit BTN/BTI models)

1. At the beginning of a heating cycle the ignition control will verify the air pressure switch circuit is open **before** the control energizes the blower motor.
2. After successfully completing the above open circuit verification step, the ignition control will energize the blower, the control will then check the air pressure switch circuit a second time **after** the blower is energized. This time the pressure switch circuit must be verified closed. The ignitor would not be energized unless this circuit closes after the blower is energized.
3. The ignition control monitors this circuit **during** the entire heating cycle to ensure it remains closed. If this circuit opens (even for a split second) during the heating cycle; the control will close the gas valve and stop the heating cycle.

By monitoring the air pressure switch circuit an ignition control can perform critical operational checks such as:

1. Verify normally open air pressure switch contacts are not stuck closed or jumpered.
2. Verify the combustion blower or inducer fan is running.
3. Verify the vent/combustion air piping length is not excessive and/or obstructed.

Paul Stewart
Technical Training Department
A. O. Smith Water Products Company
Ashland City, Tennessee

Air Pressure Switch Construction

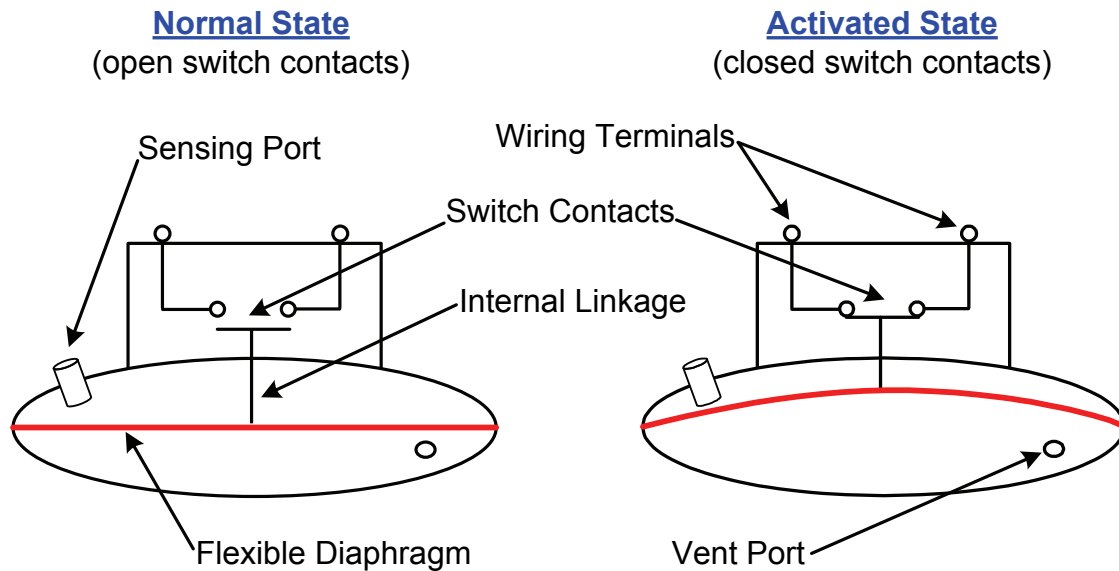

Air Pressure Switch Operation

Air pressure switches activate in response to pressure sensed through a tube. One end of this tube attaches to the pressure switch sensing port, the other end attaches to a pressure sensing port somewhere on the water heater, IE: the vent system, blower assembly.

A flexible diaphragm divides the body of the switch into two air chambers. The sensing port is attached to one air chamber. The other air chamber is vented to the atmosphere which allows the diaphragm to move. Internal linkage attaches the switch contacts to the diaphragm; with sufficient pressure applied, diaphragm movement will activate the switch contacts.

Contact States:

The “state” of the contacts refers to whether or not the switch contacts are open or closed. Closed contacts will allow electricity to flow through the switch because there is a continuous “conductive” path through the switch contacts. Open contacts will not allow electricity to flow, there is no “continuity” through the switch contacts. The state of the contacts, open or closed, can be verified/confirmed with an ohm meter. An ohm meter is required to perform conclusive diagnostic tests on air pressure switches.

With air pressure switches the term “normal state” refers to whether or not the switch contacts are open or closed when there is no pressure applied to the switch. Switches can be normally open or normally closed, abbreviated NO or NC in technical literature.

The “activated state” of a switch is the opposite of the normal state. A normally open switch in it’s activated state is closed. A normally closed switch in it’s activated state is open.

Air pressure switches are described by their normal state and by their “contact action” which is covered on the following page.

Air Pressure Switch Operation (cont)

Contact Actions:

The “action” of the contacts refers to what causes the switch to activate, to change from it’s “normal state” to its “activated state” (see page 2). On an air pressure switch this can be either a rise or fall in pressure. As the illustrations below indicate, locating the sensing port above or below the flexible diaphragm facilitates these operational differences. The contact action is further described to convey whether the contacts will open or close when the pressure sensed is sufficient to activate the switch contacts, IE: “close on a fall in pressure.”

Pressure Switch Descriptions:

Air pressure switches are described and referred to by their Contact State and Contact Action. IE: the switch on the left side in the illustration below is a “normally open, close on a fall” pressure switch. See page 7 for more information about other types of switches.

Normally Open, Close on a Fall

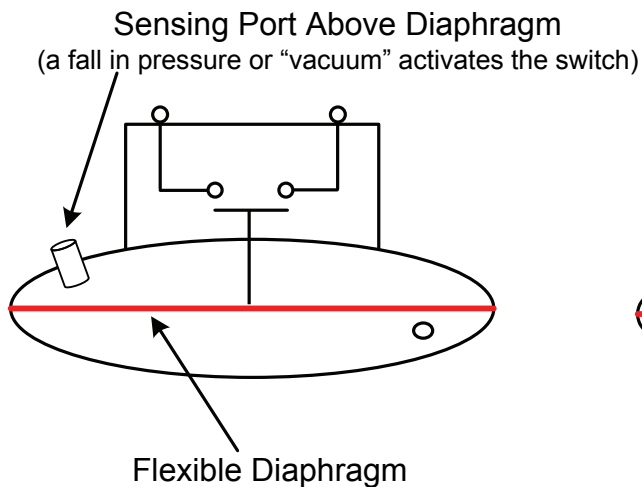

Normally Open, Close on a Rise

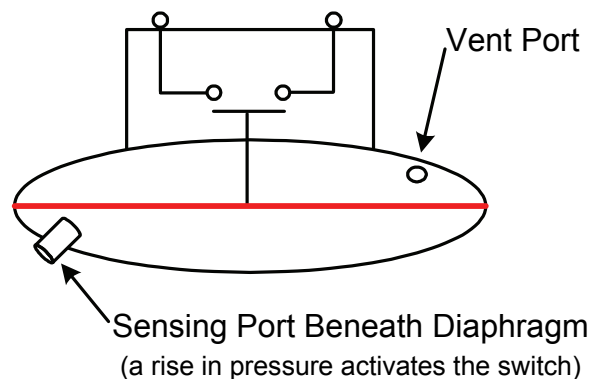

Service Note:

Because one of the two air chambers is vented to the atmosphere, the ambient (in the surrounding area) air pressure is critical. Ambient air pressure can push or pull on the diaphragm through the vent port. If the ambient air pressure is extremely high (positive) or low (negative) it may cause erratic pressure switch operation.

Direct vent installations will not eliminate this potential problem.

Tools Required for Testing

A volt/ohm multi-meter - Fieldpiece HS36 DMM (digital multi-meter) or equivalent.

A digital manometer is also required to measure pressure and perform conclusive diagnostic tests. Specifications: range; -15.0" W.C. to +15.0" W.C. resolution; 0.01" W.C. Brands/models recommended that meet these specifications include: UEI model EM-200 and Extech model 406850 dual pressure reading digital manometers.

Air Pressure Switch Testing



**Continuity Test With Ohm Meter
Power-Vent Residential Model**



**Continuity Test With Ohm Meter
BTH 120 - 250 Blocked Exhaust Switch**

Testing the performance of air pressure switches involves three procedures.

First Procedure is a normal state test to determine if the switch contacts are open or closed in the normal state (see page 2) without pressure applied. Power is turned off for this test. The wires to the switch are disconnected. A continuity test is then performed (ohm meter) between the wiring terminals on the switch. If the switch is a “normally open” switch (see page 2) the continuity test should indicate no continuity - open. If the result of this test indicated the contacts were closed, the switch must be replaced. Likewise if a “normally closed” switch’s contacts tested open in its normal state it would also have to be replaced. Note: gaining access to the switch and it’s wiring terminals may involve removing the switch, opening a control box etc.

THE SECOND AND THIRD PROCEDURES ARE PERFORMED WITH THE BLOWER RUNNING.

Second Procedure is an operational test to determine if the switch contacts are open or closed while the blower is running and pressure is applied to the switch. The wires to the switch remain disconnected and a continuity test is performed as in the first procedure above. Ensure the wires ends do not touch/short to ground. Ensure the sensing tube is properly connected at both ends and test for continuity with the blower running at full speed. Note the condition of the switch contacts; whether open or closed.

Normally open air pressure switches must close during operation and normally closed air pressure switches must remain closed throughout the heating cycle on A. O. Smith fan assisted water heaters. This information can usually be found in the sequence of operation section of the owner’s manual and/or service manual for the product. Contact the A. O. Smith technical information center (800 527-1953) for more information.

Normally open switches: If the air pressure switch being tested is a normally open switch, it must close it’s contacts (activate) before ignition can occur. If the continuity test indicates a normally open switch’s contacts have closed while the blower is running, the switch is operating correctly. If the continuity test indicates the switch contacts are remaining open while the blower is running the third “pressure test” procedure will have to be performed. This will determine if the switch is defective or if the switch contacts are failing to close because the pressure being sensed has not reached the “activation point” for the switch. This is covered on the next page.

Normally closed switches: If the air pressure switch being tested is a normally closed switch, the switch contacts must remain closed throughout the heating cycle. If the continuity test indicates a normally closed switch’s contacts remain closed while the blower is running, the switch is operating correctly. If the continuity test indicates the switch contacts are opening after the blower starts the third “pressure test” procedure will have to be performed. This will determine if the switch is defective or if the switch contacts are opening because the pressure being sensed has reached or exceeded the “activation point.” This will be covered on the next page.

Air Pressure Switch Testing (cont)



**Blocked Vent Switch - Pressure Test
Vertex Residential Power Vent Model**

The pressure activation point for the air pressure switch below is - 1.07" W. C. (inches water column)
This is a negative pressure value – in a vacuum.

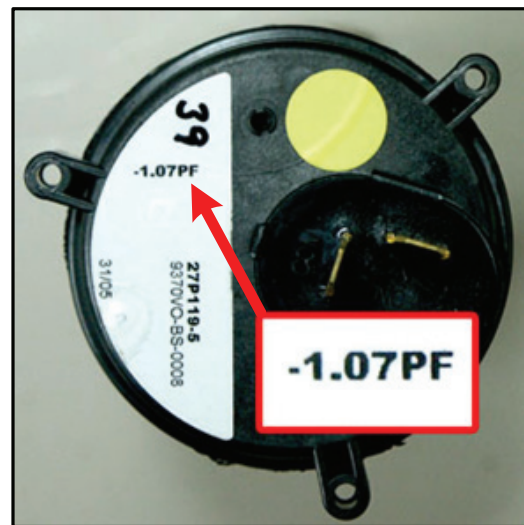

**Blocked Vent Air Pressure Switch
Residential Power Vent Model**

Third Procedure is a pressure test and requires a digital manometer capable of reading positive and negative pressures. A good range of operation would be +15.00 "W.C. to -15.00 "W.C. (inches water column) with a resolution of 0.01 "W.C. Recommend the UEI model EM-200 or Extech model 406850 dual pressure digital manometers, not shown here.

To determine if an air pressure switch is operating properly you must know the "pressure activation" point for the switch and whether it activates on a rise or a fall in pressure. The activation point is a given pressure value and may be a positive or negative (in a vacuum) pressure. This information is often provided on the switch label (see image above). Whether the switch activates on a rise or fall in pressure is the type of switch action, this information is available here (page 7) for most current residential and commercial fan assisted water heaters. Contact the technical information center 800 527-1953 when the activation point and/or switch action are not known. Have the complete water heater Model, Serial, and Series number on hand before calling.

Taking Air Pressure Readings: Disconnect the pressure sensing tube from the sensing port on the switch, leave the other end connected. Examine the sensing tube connection on the water heater, check for wear, leaks, kinks, or any kind of debris or condensate in the sensing tube, repair/replace as necessary. Connect a digital manometer to the pressure switch end of the sensing tube as shown above. Turn the power on and ensure a call for heat is active. When the blower starts and comes up to full speed, record the pressure reading.

Normally Open Switches: Normally open air pressure switches must close their contacts after the blower is energized, the pressure reading taken must reach or exceed the activation point (pressure value) for the pressure switch being tested or the contacts will not close.

Pressure reading taken DOES NOT reach activation pressure:

DO NOT replace the air pressure switch if the contacts do not close during second procedure. The switch is not defective. IE: Residential power vent product - the pressure switch on these products is a "normally open - closes on a fall in pressure" switch (see page 7). If the activation point for the switch is - 1.07" W.C. and the actual pressure reading taken was - 0.85" W.C., the actual pressure has not reached the activation point. The switch contacts will not close until the pressure reaches or exceeds - 1.07" W. C..



**Blocked Exhaust Switch Pressure Test
Cyclone - BTH 300/400 Models**



**Blocked Exhaust Switch Pressure Test
Cyclone - BTH 120 - 250 Models**

Air Pressure Switch Testing

Third Procedure - Normally Open Switches (cont):

Pressure reading taken DOES NOT reach the activation pressure (cont):

Ensure the sensing tube is connected securely and not blocked with any debris or condensate. Ensure the tube is not kinked or leaking. On residential power vent models check vent piping for excessive length or number of elbows, check for obstructions in the vent pipe. On Cyclone BTH models ensure the minimum vent pipe length requirement (7' BTH 120 - 250, 15' BTH 300/400) has been met. Ensure the blower wheel is clean on all models. This can become dirty over time or during construction on new water heaters and cause operational problems.

Pressure reading taken DOES reach the activation pressure:

If the test results for the second procedure indicated the normally open switch contacts did not close and the pressure reading taken during the third procedure indicated the pressure sensed by the switch did reach or exceed the activation point (pressure value) for the switch, the switch is defective and should be replaced.

Normally Closed Switches: Current design residential power-vent/power direct-vent and commercial BTI/ BTN models are not equipped with normally closed air pressure switches. Cyclone BTH 120 – 400 models are equipped with two normally closed air pressure switches; a blocked inlet and blocked exhaust switch (see pages 7 & 8). Normally closed switches should remain closed at all times unless there is an operational problem.

Pressure reading taken DOES NOT reach the activation pressure:

If the test results for the second procedure indicated a normally closed switches contacts were opening during blower operation AND the pressure reading taken DOES NOT reach or exceed the activation point (pressure value) for the switch, the switch is defective and should be replaced.

Pressure reading taken DOES reach the activation pressure:

If the test results for the second procedure indicated a normally closed switch contacts were opening during blower operation AND the pressure reading taken DOES reach or exceeds the activation point for the switch DO NOT replace the switch, it is not defective. Ensure the intake air or vent piping is not excessive and both are free of obstructions. Always check the owner's manual vent installation section for proper intake air and vent pipe installation requirements.

Air Pressure Switch Types

Contact States

Normally Open = NO
Normally Closed = NC

Contact Actions

Close on a rise in pressure
Close on a fall in pressure

Open on a rise in pressure
Open on a fall in pressure

Application

Normal State

Activated State

**Blocked Exhaust
Air Pressure Switch
Power-Vent & Power Direct
Vent Residential Models**

**Blower Prover
Air Pressure Switch
BTI/BTN 120 – 400 Models**

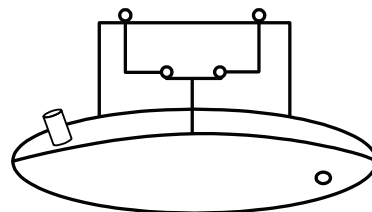
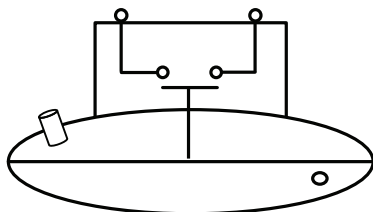

Normally open contacts, close on a fall in pressure.

**Blocked Intake
Air Pressure Switch
Cyclone BTH 120-400 Models**

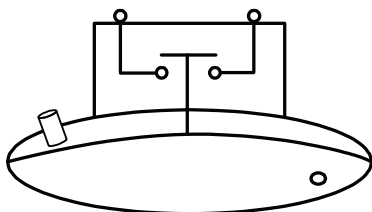
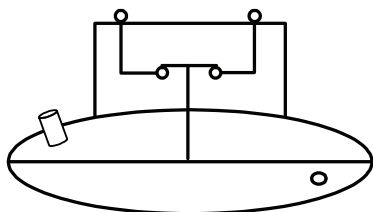

Normally closed contacts, open on a fall in pressure.

**Blower Prover
Air Pressure Switch
Cyclone BTH 120-400 Models**

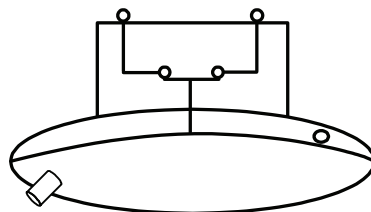
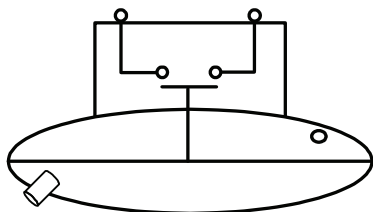

Normally open contacts, close on a rise in pressure.

**Blocked Exhaust
Air Pressure Switch
Cyclone BTH 120-400 Models**

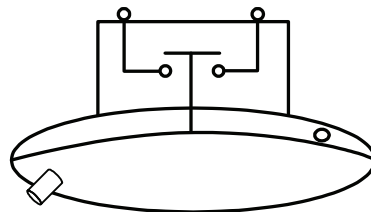
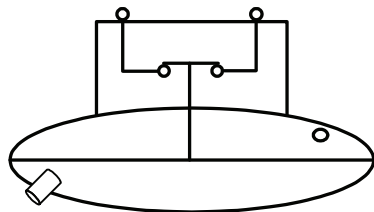

Normally closed contacts, open on a rise in pressure.

Air Pressure Switch Circuit Residential Power-Vent & Power-Direct-Vent Water Heaters

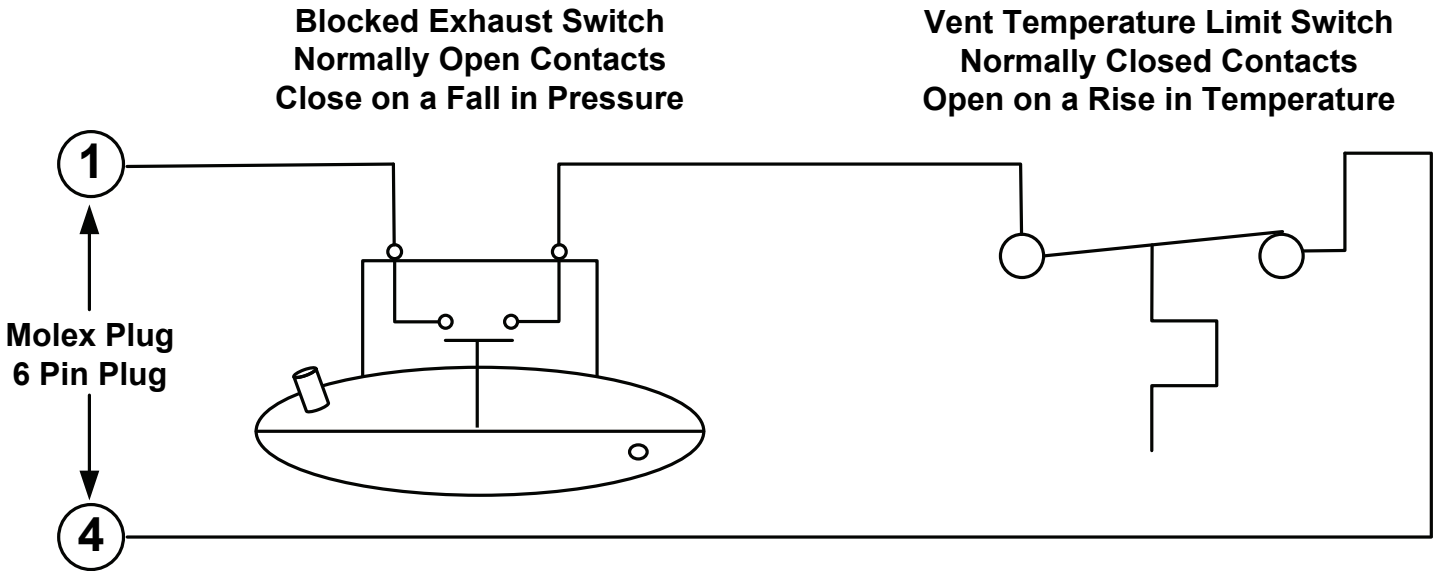

Air Pressure Switch Circuit Cyclone Water Heater

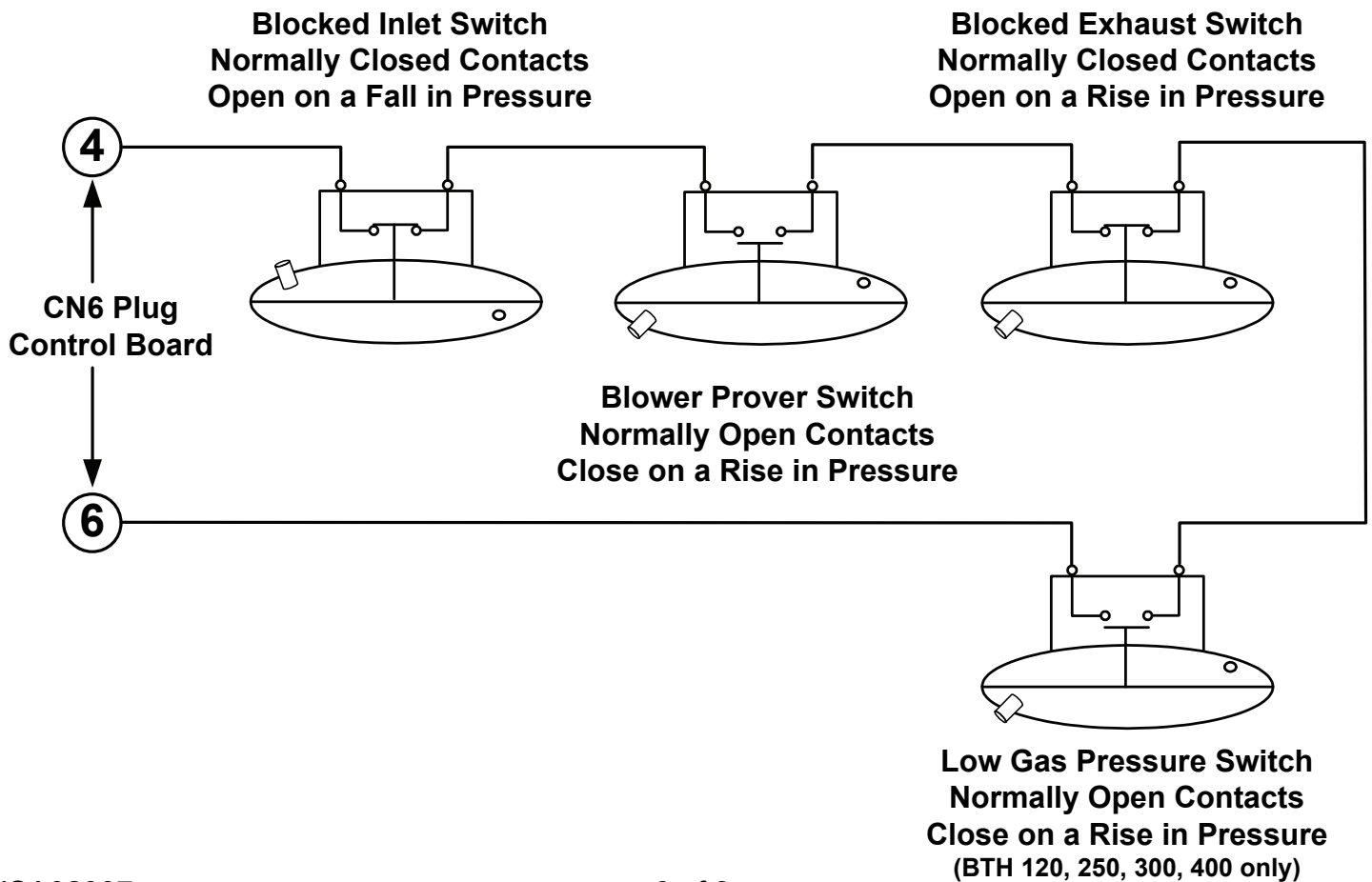

Intelli-Vent™ Sequence of Operation

