

# "SUPERFLUE"

# POWER VENTED GAS FIRED WATER HEATER

## INSTALLATION AND OPERATING INSTRUCTIONS

Read these instructions thoroughly before starting

### **⚠ WARNING:**

Improper installation, adjustment, alteration, service, or maintenance can cause injury or property damage. Refer to this manual. For assistance or additional information, consult a qualified installer, service agency, or the gas utility.

### **⚠ FOR YOUR SAFETY**

- Do not store or use gasoline or other flammable vapours and liquids in the vicinity of this or any other appliance.
- Installation and service must be performed by a qualified installer, service agency or the gas utility.

### **⚠ WARNING:**

If the information in these instructions is not followed exactly, a fire or explosion may result causing property damage, personal injury or death.

### **WHAT TO DO IF YOU SMELL GAS**

- Do not try to light any appliance.
- Do not touch any electrical switch; do not use any phone in your building.
- Immediately call your gas supplier from a neighbor's phone. Follow the gas supplier's instructions.
- If you cannot reach your gas supplier, call the fire department.



This page intentionally left blank. May be used for notes or to record other installation information.

TABLE OF CONTENTS

<b>Replacement Parts Listing/ Clearance to Combustibles</b> .....	<b>4</b>	Lighting Instructions (White-Rodgers Intelli-Vent™)	24
<b>I) INTRODUCTION</b> .....	<b>5</b>	Gas Control/Thermostat	
User Responsibilities	5	Putting the Heater into Service	
<b>II) SAFETY</b> .....	<b>6</b>	Temperature Adjustment	
For Installations in Canada:	6	Heater Shutdown	
For Installations in the United States:	6	System Error Codes	
Safety Warning (Flammable Vapours)	6	Intelli-Vent™ System Error Codes	
Safety Warning (Scalding)	6	<b>V) OPERATION</b> .....	<b>28</b>
Safety Warning (Carbon Monoxide)	6	Performance Checks	28
Relief Valve Requirements (T&P)	7	Burner Manifold Pressure	
<b>III) INSTALLATION</b> .....	<b>7</b>	Checking Input	
Unpacking the Water Heater	7	Checking burner flame	
Location Requirements	7	<b>VI) SERVICE AND MAINTENANCE</b> .....	<b>28</b>
In Earthquake Zones		Not Enough or No Hot Water	
Clearances and Accessibility	8	Energy Cut-off Control (ECO)	
Gas Supply	8	Water is Too Hot	
Gas Supply Pressure		Hot Water Odour	
Gas line purging		Discoloured Water	
Gas Leak Testing		Water Heater Makes Noise	
Gas Operating Pressures		Extended Non Use Service	
Air Requirements	9	Condensation	
General		Anode Maintenance	
Combustion Air "Supply" Ducts	9	To inspect or change an anode:	
Louvers and Grilles	9	Tank Flushing	
Air Requirements	10	Relief Valve Check	
Confined Space Air Requirements for Canadian Installations	10	Vent Maintenance	
Confined Space Air Requirements for U.S. Installations	11	Burner Maintenance	
Exhaust Venting	12	<b>VII) COMBO HEATING</b> .....	<b>31</b>
Important Notes and Warnings		System Requirements	31
Venting terminations and sizing		Installation	32
Venting instructions		Fan Coil	
Vent pipe connection to blower		Baseboard Radiator Heating	
Water Supply	16	Maintenance	32
Piping Installation		<b>VIII) TROUBLESHOOTING GUIDE</b> .....	<b>33</b>
Filling the Water Heater		SUPERFLUE™	33
Closed System/Thermal Expansion		White-Rodgers Intelli-Vent™	35
Temperature and Pressure (T&P) Relief Valve	17	<b>INSTALLATION RECORD</b> .....	<b>36</b>
The Temperature and Pressure Relief Valve:		<b>LIMITED WARRANTY</b> .....	<b>37</b>
The Discharge Line/Driptide:			
Electrical Supply	18		
Installation Checklist	19		
<b>IV) OPERATING INSTRUCTIONS</b> .....	<b>21</b>		
Temperature Regulation	21		
Mixing Valves	21		
Lighting Instructions (Robertshaw)	22		
Gas Control/Thermostat			
Putting the Heater into Service			
Temperature Adjustment			
Heater Shutdown			
Water Heater Operation			

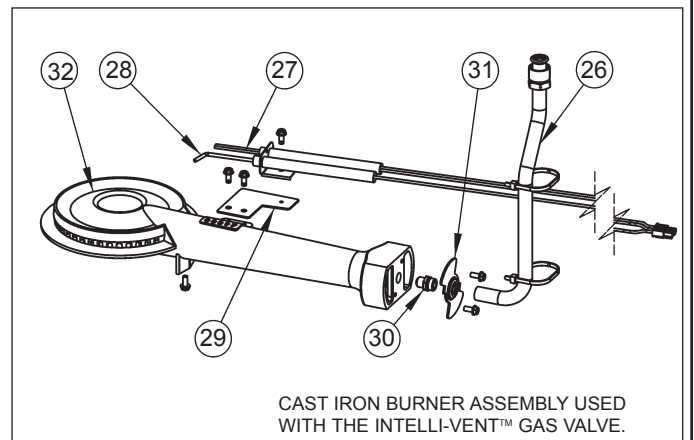
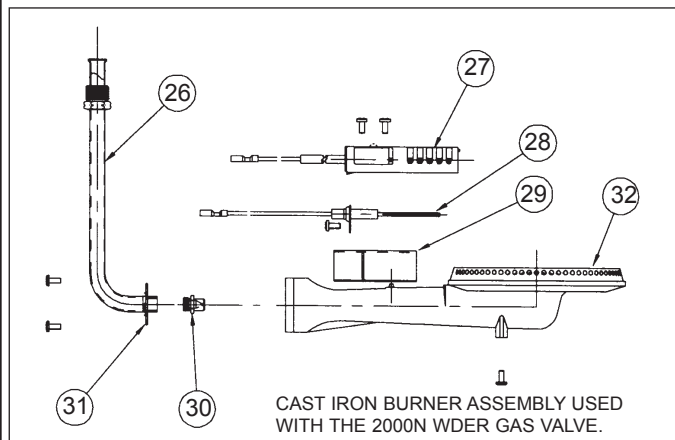
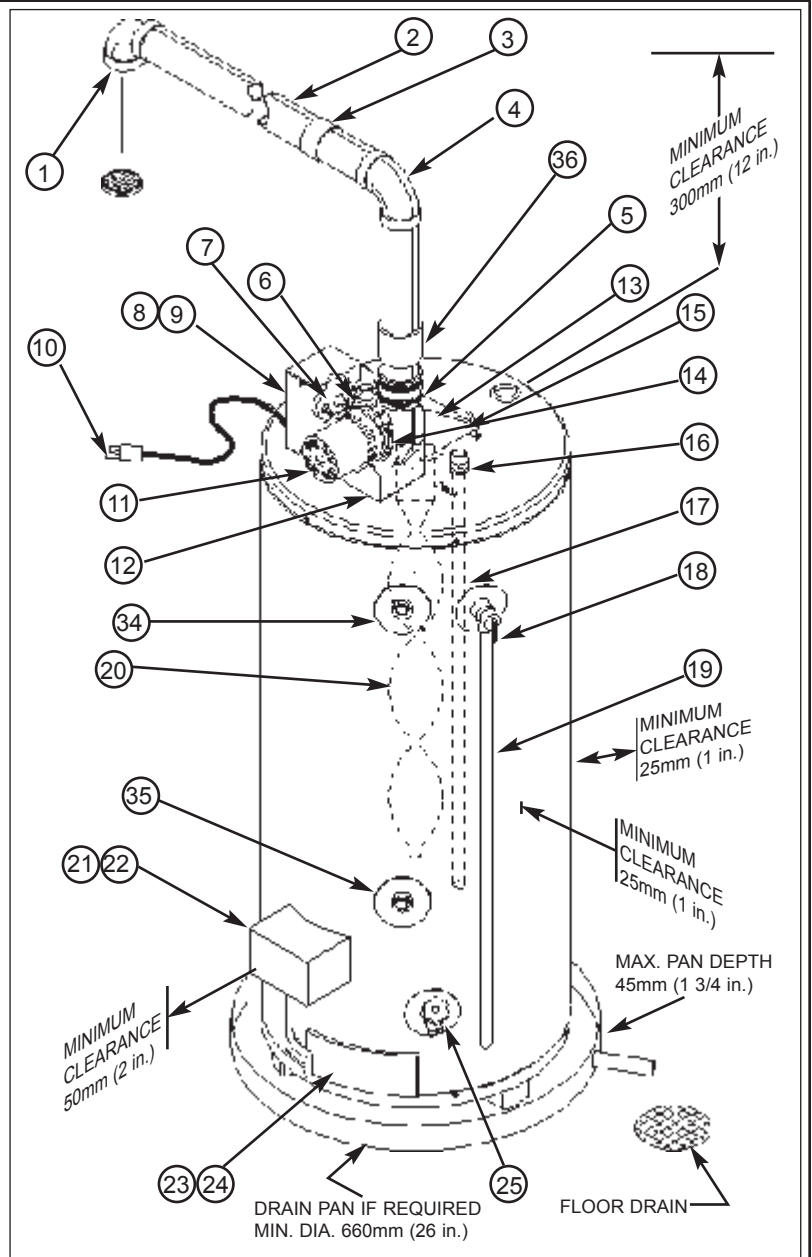
RETAIN THESE INSTRUCTIONS IN A SAFE LOCATION FOR FUTURE REFERENCE

# Replacement Parts Listing/Clearance to Combustibles

1. TERMINATION ELBOW WITH RODENT SCREEN
2. PIPE LENGTH \*
3. PIPE COUPLING \*
4. PIPE ELBOW \*
5. RUBBER COUPLING
6. AIR TUBING
7. AIR SWITCH
8. JUNCTION BOX
9. JUNCTION BOX COVER
10. POWER CORD
11. BLOWER
12. BLOWER SUPPORT BRACKET
13. DRAFT DIVERTER
14. HIGH LIMIT SWITCH
15. ANODE (UNDER CAP)
16. INLET NIPPLE
17. DIPTUBE
18. T&P VALVE
19. DRIPTUBE \*
20. BAFFLE ASSEMBLY
21. CONTROL VALVE (WHC)
22. CONTROL VALVE COVER (WHC)
23. INNER GAS DOOR
24. OUTER GAS DOOR
25. DRAIN VALVE
26. FLARE TUBE (GAS SUPPLY)
27. IGNITER ASSEMBLY
28. FLAME SENSOR
29. IGNITER BRACKET
30. ORIFICE
31. AIR SHUTTER
32. CAST IRON BURNER
- 33.
34. HEATING SYSTEM SUPPLY
35. HEATING SYSTEM RETURN
36. PVC ADAPTER

\* OWNER SUPPLIED

**Note:** Manifold Tube Connections at Control Valve;  
Right-Hand Threads for Natural Gas,  
Left-Hand Threads for Propane



**Figure 1** Water Heater and Burner Assemblies

## Your safety and the safety of others is very important.

We have provided many important safety messages in this manual and on your appliance. Always read and obey all safety messages.



This is the safety alert symbol.

This symbol alerts you to potential hazards that can kill or hurt you and others.

All safety messages will follow the safety alert symbol and either the word "DANGER" or "WARNING".



**DANGER** You can be killed or seriously injured if you don't immediately follow instructions.



**WARNING** You can be killed or seriously injured if you don't follow instructions.

All safety messages will tell you what the potential hazard is, tell you how to reduce the chance of injury, and tell you what can happen if the instructions are not followed.

## I) INTRODUCTION

We thank you for choosing a GSW/John Wood Water Heater. Your satisfaction with this product is very important to us. This gas-fired water heater has been developed to produce potable hot water and may also be used in combination with space heating applications. The "Superflue"™ series is designed to vent the products of combustion (flue gases) horizontally through an exterior wall or vertically through the roof using an integrated blower assembly and plastic piping, without the need for a conventional chimney.

### User Responsibilities

This manual has been prepared to acquaint you with the installation, operation and maintenance of your gas fired water heater and provide important safety information in these areas. It is your responsibility to ensure that your water heater is properly installed and cared for.

**FAILURE TO FOLLOW THE INSTRUCTIONS IN THIS MANUAL MAY RESULT IN SERIOUS BODILY INJURY AND/OR PROPERTY DAMAGE. THOROUGHLY READ AND UNDERSTAND ALL INSTRUCTIONS BEFORE YOU ATTEMPT TO INSTALL, OPERATE OR MAINTAIN THIS HEATER.**

Installation and service requires trade knowledge in the areas of plumbing, electricity, venting, air supply and gas supply. If you lack these skills or have difficulty understanding these instructions, you should not proceed. Enlist the help of a qualified service technician to install this water heater.

Examples of qualified service technicians include those trained in the plumbing and heating industry, local gas utility personnel or an authorized service person.

Service to the Power Vent System should only be performed by a qualified service technician.

The manufacturer and seller of this water heater will not assume any liability for any property damage, personal injury or death resulting from improper sizing, installation or failure to comply with these instructions.

The warranty on this water heater is in effect only when the water heater is installed and operated in accordance with these instructions. A data plate identifying your water heater can be found above the gas control/thermostat. When referring to your water heater, always have the information listed on the data plate readily available.

**Protect your warranty:** Regularly service your water heater as directed in the "Maintenance" section of this manual.

Retain your original receipt as proof of purchase.

**Do not discard this manual. You or future users of this water heater will need it for reference.**

## II) SAFETY

This water heater is design-certified by CSA International as a Category III, non-direct vented water heater that takes its combustion air either from the installation area or from air ducted to the unit from the outside.

In addition to the installation instructions found in this manual, the water heater must be installed in accordance with all local and provincial or state codes or, in the absence of such, with the latest editions of the following specifications.

### For Installations in Canada:

"Natural Gas and Propane Installation Code" CAN/CSA-B149.1 and "Canadian Electrical Code" (CAN/CSA C22.1), Part I available from:

Canadian Standards Association,  
5060 Spectrum Way,  
Mississauga, Ontario, Canada  
L4W 5N6

### For Installations in the United States:

"National Fuel Gas Code" ANSI Z223.1 (NFPA 54) and "National Electrical Code" (NFPA 70) available from:

American National Standards Institute,  
25 West 43rd Street,  
New York, NY 10036

**Massachusetts code** requires this water heater to be installed in accordance with Massachusetts Plumbing and Fuel Gas Code 248 CMR Section 2.00 and 5.00.

Check your phone listings for the local authorities having jurisdiction over your installation.

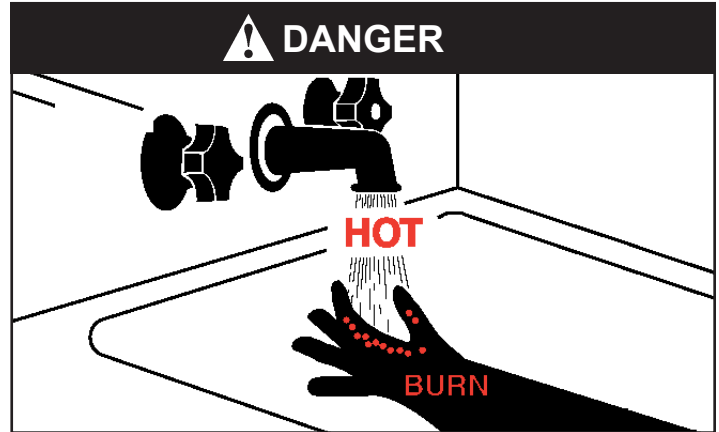
### Safety Warning (Flammable Vapours)



There is a risk of property damage, personal injury or death from the by-products of combustion (e.g., flue gases), in using fuel-burning appliances such as water heaters. Areas that may not be suitable for water heater installation include those where flammable liquids, gasoline, solvents, adhesives etc. are stored, or where engine-driven equipment or vehicles are stored, operated or repaired. These, and simi-

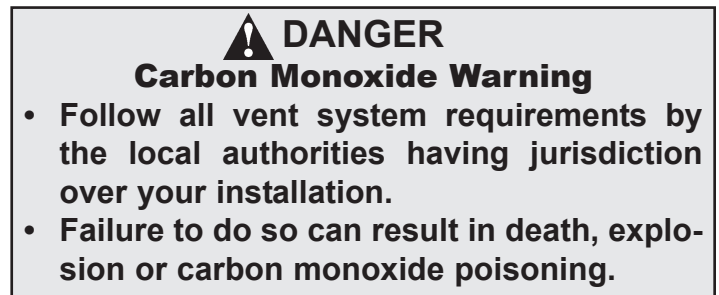
lar products, should not be stored or used near the water heater or air intake. Due to the nature of air movement, flammable vapours can be carried some distance from the point of storage. The gas-fired water heater igniter or burner flame can ignite these vapours causing a flashback, fire or explosion, which may result in severe property damage, serious personal injury or death. If flammable liquids or vapours have spilled or leaked in the area of the water heater, leave the area immediately and call the fire department from a neighbor's home. Do not attempt to clean the spill until all ignition sources have been extinguished.

### Safety Warning (Scalding)



Hot water produced by this appliance can cause severe burns due to scalding. The hazard is increased for young children, the aged or the disabled when water temperatures exceed 52°C (125°F). Use tempering valves, also known as mixing valves, in the hot-water system to reduce the risk of scalding at point-of-use such as lavatories, sinks and bathing facilities (see Figure 16). Such precautions must be followed when this heater is operated in combination with dishwashing or space heating applications.

### Safety Warning (Carbon Monoxide)



As with all fuel burning equipment, this heater requires an adequate supply of air for combustion and ventilation. An insufficient air supply can result in poor combustion or the re-circulation of the flue gases. Such a condition can cause soot build-up and present a fire hazard. Flow reversal of flue gases can cause an increase of carbon monoxide inside of the dwelling that could result in serious bodily harm or death from asphyxiation.

**MAKE SURE THE FLOW OF COMBUSTION AND VENTILATION AIR IS NOT RESTRICTED.**



## Relief Valve Requirements (T&P)

All water heaters must be fitted with a proper temperature and pressure relief valve. These valves must be certified as meeting the requirements of the "Standard For Relief Valves For Hot Water Supply Systems", ANSI Z21.22/CSA 4.4.

If this water heater has been exposed to flooding, freezing, fire or any unusual condition, do not put it into operation until it has been inspected and approved by a qualified service technician. **THESE CONDITIONS CAN RESULT IN UNSEEN INTERNAL DAMAGE** and are not subject to warranty coverage.

### CAUTION

Hydrogen gas can be produced in a hot water system served by this heater that has not been used for a long period of time (generally two (2) weeks or more). **Hydrogen gas is extremely flammable and can ignite when exposed to a spark or flame.** To reduce the risk of injury under these conditions, it is recommended that the hot water faucet be opened for several minutes at the kitchen sink before using any electrical appliance connected to the hot water system. Use caution in opening faucets. If hydrogen is present, there will probably be an unusual sound such as air escaping through the pipe as the water begins to flow. There should be no smoking or open flame near the faucet at the time it is open.

## III) INSTALLATION

### Unpacking the Water Heater



### WARNING Excessive Weight Hazard

**Use two or more people to move and install water heater. Failure to do so can result in back or other injury.**

**Important:** Do not remove any permanent instructions, labels, or the data label from outside of the water heater or on the inside of panels.

- Remove exterior packaging and place installation components aside.
- Inspect all parts for damage prior to installation and start-up.
- Completely read all instructions before attempting to assemble and install this product.

If you observe damage to the water heater or any of its components, **DO NOT ASSEMBLE OR INSTALL IT OR MAKE ANY ATTEMPT TO FIX THE DAMAGED PART(S)**. Contact the place of purchase for further instructions.

- After installation, dispose of packaging material in the proper manner.

### IMPORTANT:

This water heater must be installed strictly in accordance with the instructions enclosed, and local electrical, fuel and building codes. It is possible that connections to the water heater, or the water heater itself, may develop leaks. **IT IS THEREFORE IMPERATIVE** that the water heater be installed so that any leakage of the tank or related water piping is directed to an adequate drain in such a manner that it cannot damage the building, furniture, floor covering, adjacent areas, lower floors of the structure or other property subject to water damage. This is particularly important if the water heater is installed in a multi-story building, on finished flooring or carpeted surfaces. GSW **WILL NOT ASSUME ANY LIABILITY** for damage caused by water leaking from the water heater, pressure relief valve, or related fittings. Select a location as centralized within the piping system as possible. In any location selected, it is recommended that a suitable drain pan be installed under the water heater. This pan must limit the water level to a **MAXIMUM** depth of 45mm (1 3/4 in.) and have a diameter that is a minimum of 50mm (2 in.) greater than the diameter of the water heater. Suitable piping shall connect the drain pan to a properly operating floor drain. When used with a fuel-fired heater, this drain pan must not restrict combustion air flow.

### Location Requirements

The water heater must be installed indoors in an area not subject to freezing temperatures and in a vertical position on a level surface. Water heaters located in unconditioned spaces (e.g., attics, basements etc.) may require insulation of the water piping, drain piping and venting to protect against condensation. The power vented series of water heaters are designed to vent the products of combustion horizontally through the wall or vertically through the roof. The blower expels the products of combustion by means of plastic piping to the outdoors without the need for a conventional chimney.

Select a location as centralized within the piping system as possible. The heater should be located in an area where leakage of the tank or connections will not result in damage to the area adjacent to the water heater or to lower floors of the structure (see "IMPORTANT" notice above). Before installing this water heater, consideration and planning must be given to the following details:

- Proximity to walls and other objects (see "Clearance and Accessibility").
- Air supply (see "Air Requirements").
- Access to gas supply (see "Gas Supply").
- Routing and support of the vent piping and termination (see "Exhaust Venting").
- Position of water supply and placement of water piping and floor drain (see "Water Supply").

### In Earthquake Zones

**Note:** The water heater must be braced, anchored, or strapped to avoid moving during an earthquake. Contact local utilities for code requirements in your area.

**Note:** The water heater may be installed in a closet with a door off a bedroom or bathroom providing the units are installed and vented per the manufacturer's instructions.

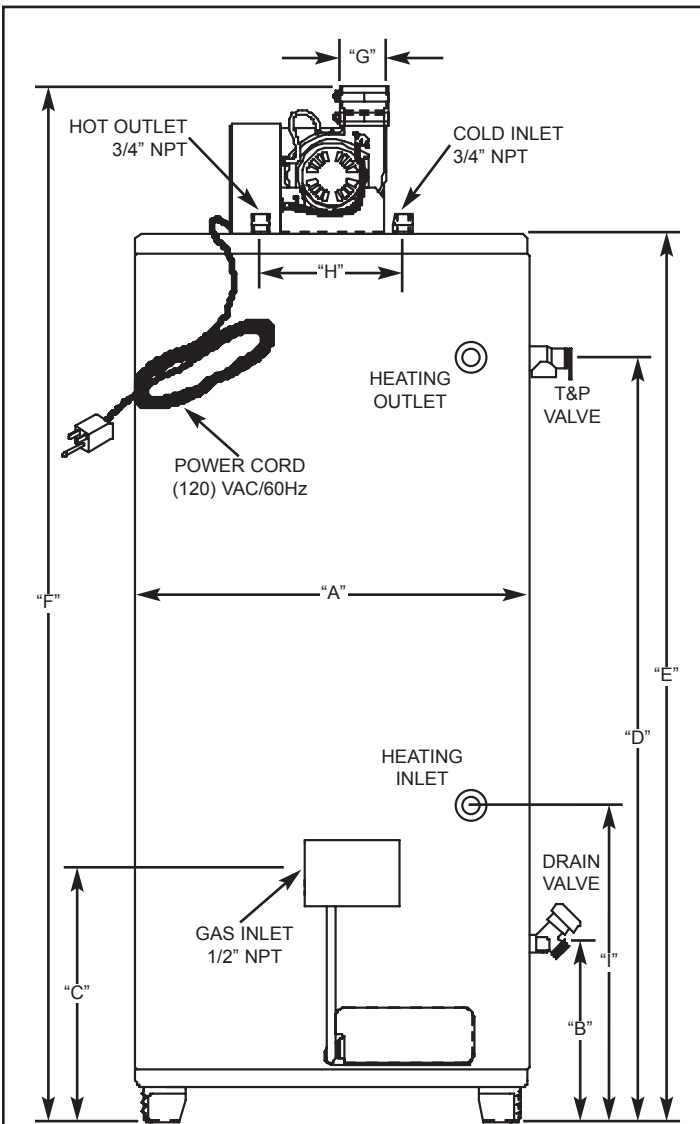
**Important:** If installing over carpeting, the carpeting must be protected by a metal or wood panel beneath the water heater. The protective panel must extend beyond the full width and depth of the water heater by at least 76mm (3 in.) in each direction or if in an alcove or closet installation, the entire floor must be covered by the panel.

**Clearances and Accessibility**

- The minimum clearances between the heater and combustible materials are:

Top	300mm (12 in.)
Front	100mm (4 in.)
Rear and Sides	25mm (1 in.)

**Note:** These requirements are also listed on the data plate located on the front of the water heater.



MODEL NO.	A	B	C	D	E	F	G	H	I	
G/JW75	mm	610	302	432	1388	1575	1826	76	305	537
	in.	24	11-7/8	17	54-5/8	62	71-7/8	3	12	21-1/8

**Figure 2** Rough-in Dimensions

- The water heater is certified for installation on a combustible floor.

Figure 2 may be used as a reference guide to locate the specific clearance locations. A minimum of 600mm (24 in.) of front clearance and 100mm (4 in.) on each side should be provided for inspection and service.

**Gas Supply**

**⚠ DANGER**

**Explosion Hazard**

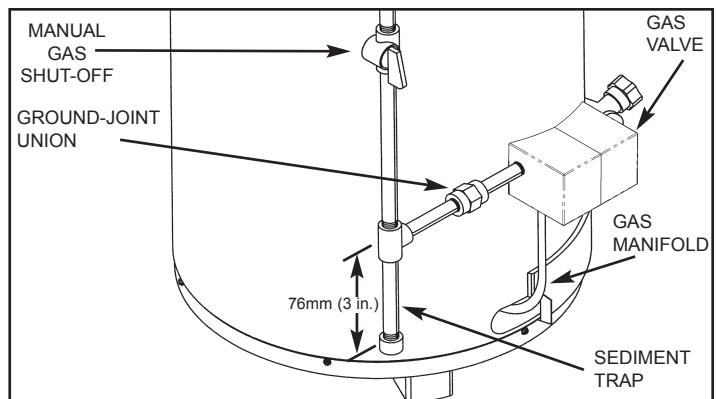
- Use a new CSA approved gas supply line.
- Install a gas supply shut-off valve.
- Do not connect a natural gas water heater to a L.P. gas supply.
- Do not connect a L.P. gas water heater to a natural gas supply
- Failure to follow these instructions can result in death, an explosion or carbon monoxide poisoning.

Read the data plate to be sure the water heater is made for the type of gas you will be using in your home. This information will be found on the data plate located above the gas control valve. If the information does not agree with the type of gas available, do not install or attempt to start. Call your dealer.

**Note:** An odourant is added by the gas supplier to the gas used by this water heater. This odourant may fade over an extended period of time. Do not depend upon this odourant as an indication of leaking gas.

This gas piping must be installed in accordance with all local and provincial or state codes or, in the absence of such, the latest edition of "Natural Gas and Propane Installation Code" CAN/CSA-B149.1 (Canada), or "National Fuel Gas Code" ANSI Z223.1 (NFPA 54) (U.S.A.).

Use properly sized gas piping and to ensure full gas input and a properly sized gas supply regulator to ensure ade-



**Figure 3** Gas Piping



quate gas supply pressure. The supply piping and regulator must be large enough to satisfy the requirements of all appliances connected to the gas service and when all appliances are operating simultaneously. Undersize piping and insufficient pressure can restrict the gas flow causing the water heater to perform poorly. Improperly sized piping may pose a safety hazard.

**Note:** When installing gas piping, apply sealing compounds approved for use with natural and propane gas.

1. Install a readily accessible manual shut-off valve in the gas supply line as recommended by the local utility. The owner/operator must be shown the location of this valve and be given instructions on how to use it to shut off the gas to the heater.
2. Install a drip leg (if not already incorporated as part of the water heater) as shown. The drip leg must be no less than 76mm (3 in.) long for the accumulation of dirt, foreign material, and water droplets.
3. Install a ground joint union between the gas control /thermostat and the manual shut-off valve. This is to allow easy removal of the gas control/thermostat.
4. Turn the gas supply on and check for leaks. Use a chloride-free soap and water solution (bubbles forming indicate a leak) or other approved method.

### Gas Supply Pressure

**WARNING**  
Exposure to a higher gas supply pressure may cause damage to the control, resulting in explosion or fire. Consult your local gas supplier and gas authorities. DO NOT PUT INTO SERVICE IF OVER-PRESSURIZATION HAS OCCURRED.

**Important:** The gas supply pressure must not exceed the maximum supply pressure as stated on the water heater's data plate.

#### Gas line purging

Air may be present in the gas lines and could prevent the burner from lighting on initial start-up. The gas lines should be purged of air by a qualified service technician after installation of the gas piping system.

#### Gas Leak Testing

**Important:** This water heater and its gas connection must be leak tested before placing the appliance in operation.

- If the code requires the gas lines to be tested at a pressure exceeding 14 in. w.c. (3.5 kPa), the water heater and its manual shut-off valve must be disconnected from the gas supply piping system and the line capped.
- If the gas lines are to be tested at a pressure less than 14 in. w.c. (3.5 kPa), the water heater must be isolated from the gas supply piping system by closing its manual shut-off valve.

### Gas Operating Pressures

The gas supply pressure and burner manifold pressure is listed on the data plate located on the front of the heater above the gas control/thermostat. Ensure the gas supply pressure to the water heater and the burner manifold pressure are properly adjusted while all appliances are in operation. Refer to Figure 20 for Gas Control/Thermostat Details.

U.L. and CSA recognized fuel gas and Carbon Monoxide (CO) detectors are recommended in all applications and should be installed using the manufacturer's instructions and local codes, rules or regulations.

### Air Requirements

**WARNING**  
Failure to properly install this heater may result in a fire hazard.

#### General

- An adequate air supply shall be provided for combustion and ventilation of this water heater. An insufficient supply can result in poor combustion and possible sooting of the burner, combustion chamber or flue passageway. This may present a potential fire hazard or could create a serious health hazard by producing carbon monoxide.

Where an exhaust fan or any other air consuming appliance (e.g., clothes dryer, furnace, etc.) is installed in the same space as the water heater, sufficient air openings must be available to provide fresh air when all appliances are operating simultaneously.

For buildings that are not well-sealed (do not have tight fitting doors and windows) natural air infiltration may provide sufficient air required for combustion and ventilation. For buildings using tight construction (newer and renovated structures), the air supply shall be introduced from the outdoors, regardless of whether the space is confined or unconfined.

#### Combustion Air "Supply" Ducts

Air supply ducts shall be of galvanized steel or equivalent corrosion resistant material. A single air duct may not be substituted when required for upper and lower air openings. Horizontal combustion air ducts shall not slope downward toward the air inlet.

#### Louvers and Grilles

Openings for air supply ducts must provide free unobstructed air movement. Louver and grille openings must be sized to ensure that the FREE OPEN AREA is never less than the area of the air duct.

## Air Requirements

**Important:** Air for combustion and ventilation must not come from a corrosive atmosphere. Any failure due to corrosive elements in the atmosphere is excluded from warranty coverage.

Installations in or for certain places including, but not limited to, those listed below will require outdoor air for combustion to reduce the risk of chemical exposure:

- Beauty shops
- Photo processing labs
- Buildings with indoor pools
- Water heaters installed in laundry, hobby or craft rooms
- Water heaters installed near chemical storage areas

In such circumstances, outdoor combustion air may reduce, but will not eliminate the presence of corrosive chemicals in the air. Combustion air must be free of acid-forming chemicals such as sulfur, fluorine and chlorine. These elements are found in aerosol sprays, detergents, bleaches, cleaning solvents, air fresheners, paint and varnish removers, refrigerants and many other commercial and household products. When burned, vapours from these products form highly corrosive acid compounds. These products should not be stored or used near the water heater or air inlet.

The area in which the heater is located is classified as either "an **unconfined space**" or "a **confined space**."

An **unconfined space** is defined as a space having a volume not less than 50 cubic feet per 1000 BTU/hour (4.8 cubic metres per kilowatt) of combined input rating of all appliances using the space. Adjacent open rooms may be included as part of the unconfined space, **provided there are no closeable doors between these rooms**. An example of this is an open basement.

A **confined space** is one smaller than described above. For buildings using tight construction (newer and renovated structures), the air supply shall be introduced from the outdoors, regardless of whether the space is confined or unconfined.

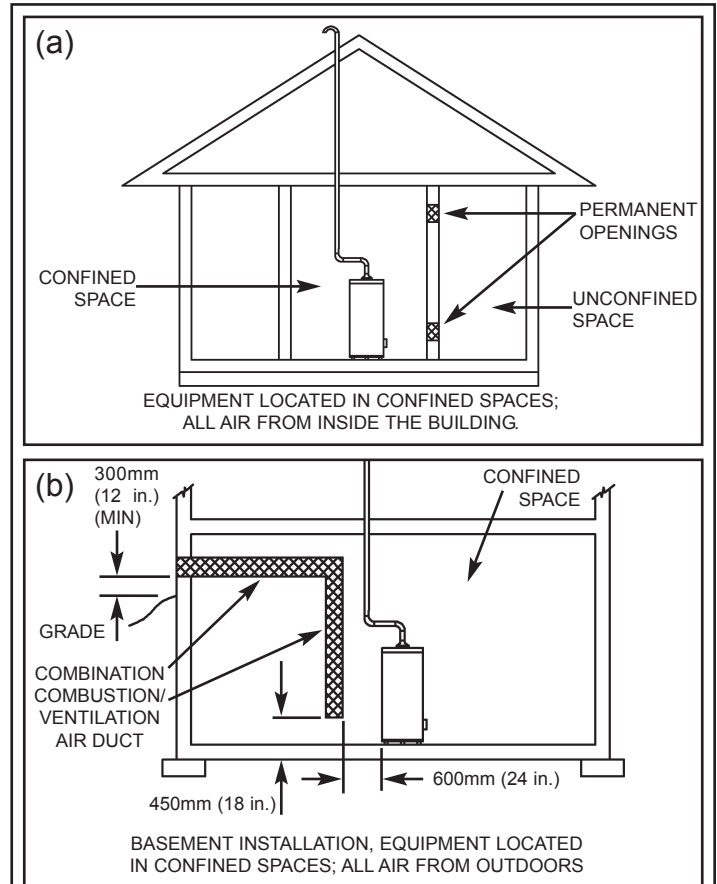
## Confined Space Air Requirements for Canadian Installations

Refer to Figure 4 (a), or (b), and Table 1 for proper sizing and location of combustion air ducts and openings. **CHECK LOCAL CODES.**

- a). Two permanent openings shall be provided connecting the confined space (e.g., closet, small room) with the unconfined space. Each opening shall have a free area of one square inch per 1,000 BTU/hour input (22 cm<sup>2</sup>/kW) of all appliances in the confined space. The top opening shall be located as close to the ceiling as practical but never lower than the top of the heater. (see Figure 4 (a)). The bottom opening shall be located neither more than 450mm (18 in.), nor less than 150mm (6 in.), above floor level.

**Note:** Ensure sufficient ventilation air to prevent elevated temperatures in closets and confined spaces.

- b). When using a single air supply, the duct shall terminate within 300mm (12 in.) above and within 600mm (24 in.) horizontally of the burner level of the appliance having the largest input. For example: GSW's water heaters' burners are 150mm (6 in.) from the floor, plus 300mm (12 in.) equals 450mm (18 in.) as shown in Figure 4 (b). All exterior vent openings are to be at least 300mm (12 in.) above the ground and clear of snow levels.



**Figure 4** Combustion Air Supply Openings And Ducts (Canada)

Combined Input of All Appliances in Confined Space*		Required Free Area		Acceptable Round Duct Size Diameter			
				A**		B***	
BTU / h	(kW / hr)	cm <sup>2</sup>	in. <sup>2</sup>	mm	in.	mm	in.
75,000	23	70	11	100	4	125	5
100,000	30	90	14	100	4	125	5
125,000	37	120	18	125	5	150	6
150,000	45	140	22	125	5	150	6

\* All appliances refers to, and includes, those appliances using the same air source (e.g. water heater, furnace, boiler, clothes dryer etc.).

\*\* Maximum allowable length of ductwork listed in column A is 6.1 equivalent metres (20 ft.).

\*\*\* Maximum allowable length of ductwork listed in column B is 15.2 equivalent metres (50 ft.).

**Table 1** Air Supply Sizing (Canada)

## Confined Space Air Requirements for U.S. Installations

Refer to Figure 5 (a), (b), (c) or (d) for proper sizing and location of combustion air ducts and openings. **CHECK LOCAL CODES.**

### (a) Equipment located in confined spaces; all air from inside the building.

Two permanent openings shall be provided connecting the confined space (e.g., closet, small room) with the unconfined space. Each opening shall have a free area of one square inch per 1,000 BTU/hour input ( $22 \text{ cm}^2/\text{kW}$ ) of all appliances in the confined space, but not less than 100 square inches ( $645 \text{ cm}^2$ ). The top opening shall commence within 300mm (12 in.) of the top of space and the bottom opening shall commence within 300mm (12 in.) of the bottom of the enclosure.

### (b) Basement installation, equipment located in confined spaces; all air from outdoors.

When supplying air directly from the outdoors, each opening shall have a minimum free area of one square inch per 4,000 BTU/hour input ( $5.5 \text{ cm}^2/\text{kW}$ ) of total input rating of all appliances in the confined space. The inlets shall be a minimum of 300mm (12 in.) above the grade (snow) line. The top opening shall commence within 300mm (12 in.) of the top of the confined space.

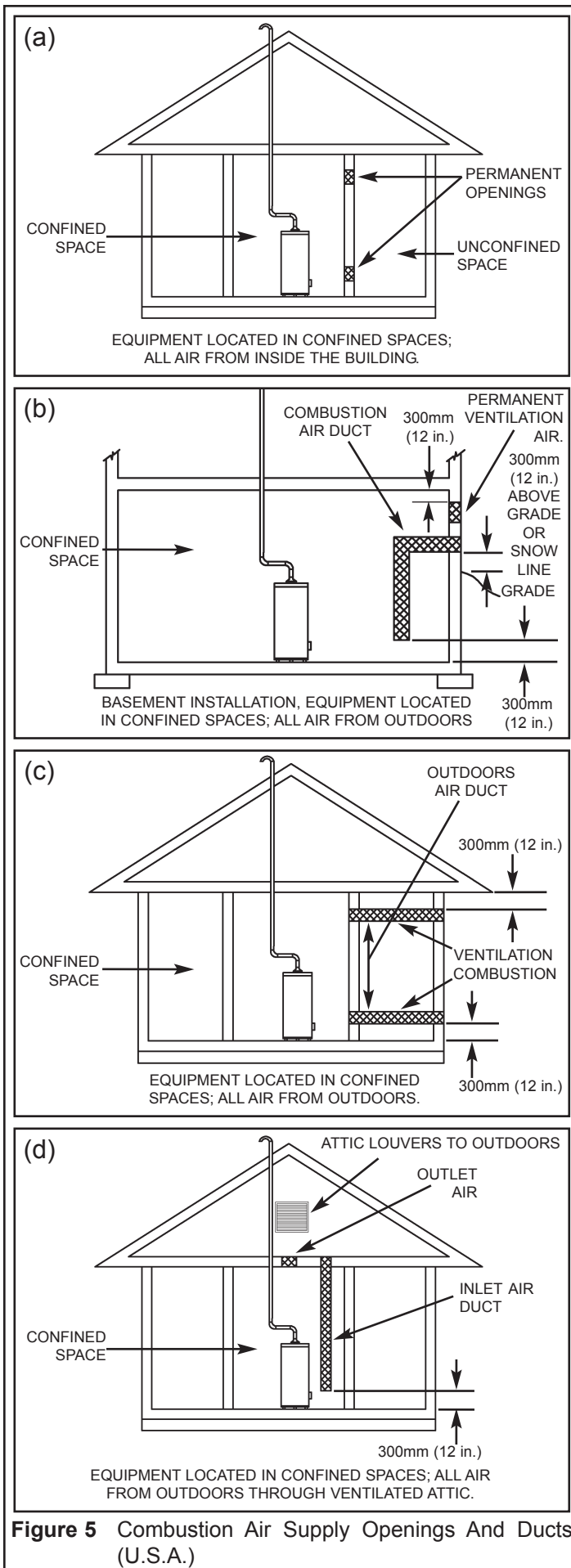
### (c) Equipment located in confined spaces; all air from outdoors.

When supplying air directly from the outdoors using horizontal ducting, each opening shall have a free minimum area of one square inch per 2,000 BTU/hour ( $11 \text{ cm}^2/\text{kW}$ ) of total input rating of all appliances in the confined space.

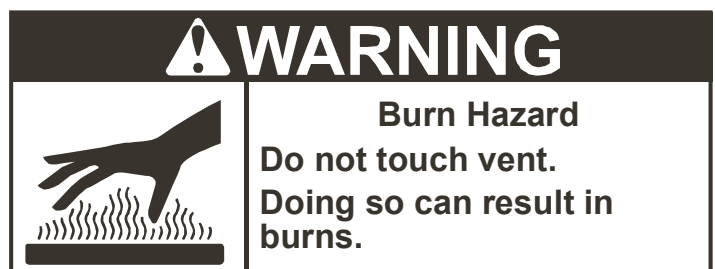
### (d) Equipment located in confined spaces; all air from outdoors through ventilated attic.

When supplying air directly through vertical ducting, each opening shall have a free minimum area of one square inch per 4,000 BTU/hour ( $5.5 \text{ cm}^2/\text{kW}$ ) of total input rating of all appliances in the confined space.

**Note:** Ensure sufficient ventilation air to prevent elevated temperatures in closets and confined spaces.



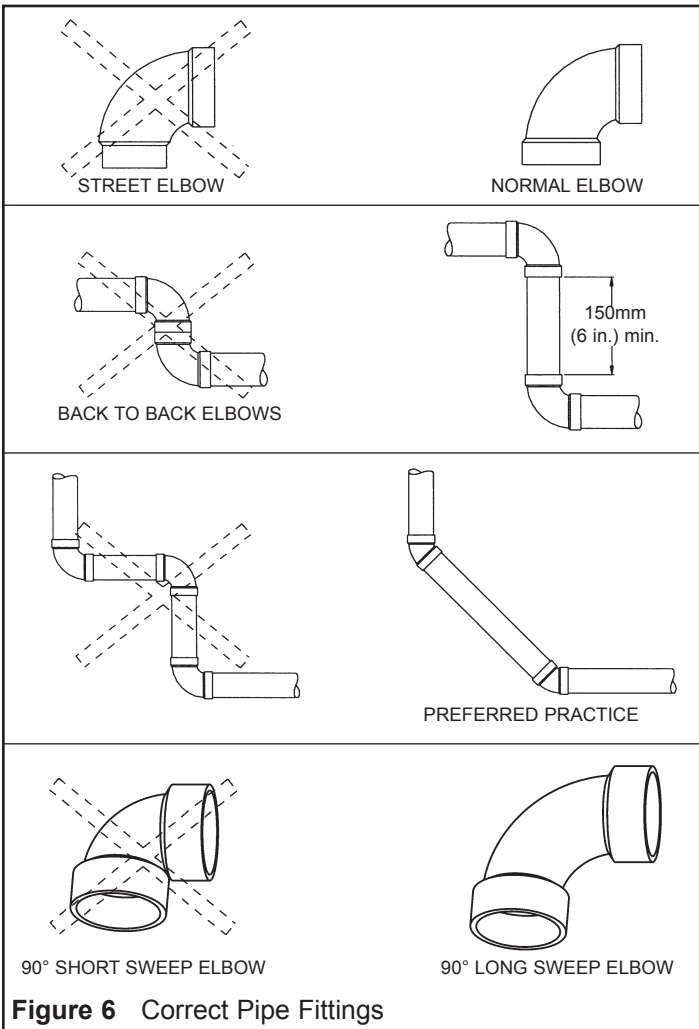
**Figure 5** Combustion Air Supply Openings And Ducts (U.S.A.)



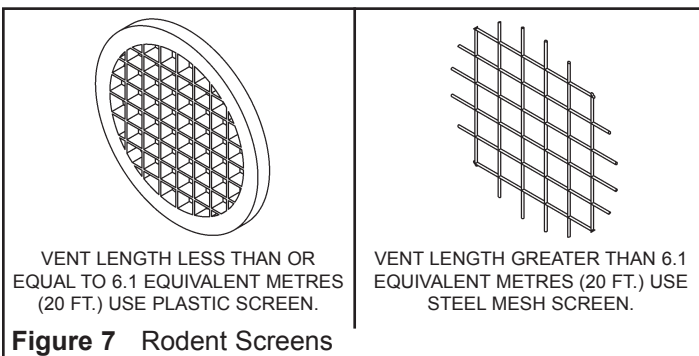
## Exhaust Venting

This heater is designed to exhaust the products of combustion (flue gases) to the outdoors using a sealed piping system. Table 2 lists the allowable vent materials and sizing information. Figure 8 shows the general venting layout while Figures 9-12 show various end termination details and clearances. Connection of the venting piping to the blower is shown in Figure 14.

Correct installation of the venting system is essential to the safe and efficient operation of this water heater. Vent piping must be installed in accordance with all applicable local and provincial or state codes. In the absence of such codes, all installation shall meet the requirements as stated in the latest edition of the **"Natural Gas and Propane Installation Codes" CAN/CSA-B149.1** (Canada) or **"National Fuel Gas Code" ANSI Z223.1 (NFPA 54)** (U.S.A.).



**Figure 6** Correct Pipe Fittings



**Figure 7** Rodent Screens

## Important Notes and Warnings

- This heater is certified to be installed using Schedule 40 PVC or CPVC plastic vent material. In Canada some jurisdictions require that this material be approved to ULC S636. ULC S636 mandates that components from different systems must not be mixed in the same vent runs. Check local codes to determine which materials are allowed in your area and only use approved material. All venting material and components must be joined with the approved primer/cleaner and solvent cement.
- Do not common vent this heater with any other appliance.
- During operation the plastic piping will expand as it heats up and contract as it cools down. This is normal for this type of venting. Rigidly fastening the vent piping can cause undue stress that may result in the cracking or fracturing the vent piping material. A fracture of the venting pipe poses a serious safety hazard. To prevent stressing of the vent system, all hangers and supports must allow the vent piping freedom to move.
- All power vented water heaters generate a certain amount of operational noise. In order to minimize noise transmission to the support structure, use isolation pads between the pipe hangers and the vent pipe.
- Most power vent installations develop some condensation in the vent piping. When using long runs of venting or when the venting passes through cold or unheated areas, considerable amounts of condensate from the flue gases can develop. Provision must be made for the condensate to drain freely from the system or to be collected in a condensate trap(s) that can be drained. Damage or fracture of the vent piping may occur if the condensate is allowed to collect and freeze. Pooling of condensate can restrict airflow and can cause nuisance failures of the system.
- Be aware of any concealed wiring or piping inside the walls.



## Venting terminations and sizing

- Refer to Figure 8 and Table 2 for vent pipe materials and sizing and Figure 11 for vent termination clearances. Examples of the vent terminations are shown in Figures 9 and 10. If the installation requires a vent riser, suitable drainage must be provided to ensure condensation does not accumulate. Termination through a roof is shown Figure 12.
- G/JW75 gallon models are supplied with a 76mm (3 in.) termination elbow that includes a steel mesh rodent screen and a 76mm (3 in.) plastic screen.
- The screen is required to keep foreign objects, rodents and small birds from entering the venting system and only one (1) screen is to be installed in the termination elbow. These screens have been sized to ensure maximum energy efficiency of the venting system based on the "equivalent length" of the vent piping. How to determine the equivalent length is shown in Figure 8. The appropriate screen is to be installed into the end of the termination elbow and secured with a small amount of silicone sealant. This will allow for easy removal for inspection and cleaning.

## Venting instructions

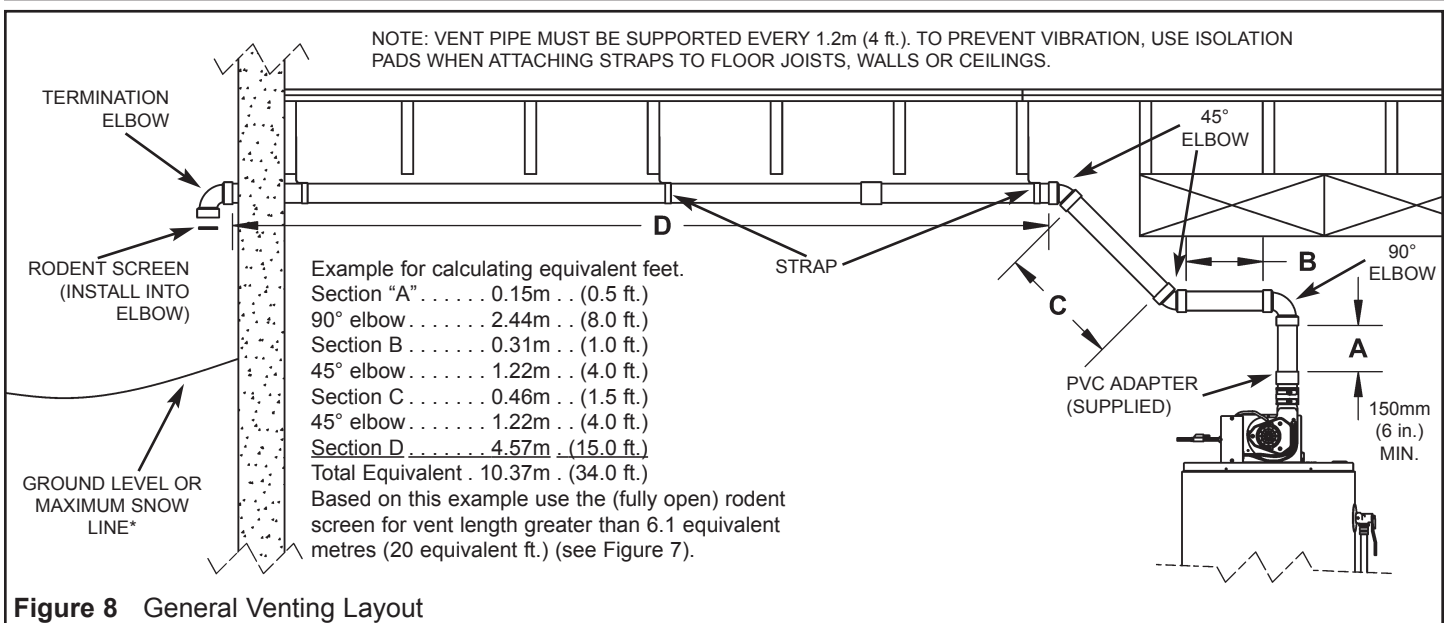
- Plan the venting layout starting at the vent termination and work back toward the heater. Take into consideration the style and position of the vent termination, the vent pipe routing, elbows and connectors required and the necessary support hangers.
- G/JW75 gallon heaters use 76mm (3 in.) schedule 40 venting material. Allowable venting length is determined using the "Equivalent vent length" method described in Table 2. See also section on "Vent pipe connection to blower".
- Venting should be as direct as possible with the fewest number of fittings. Use long radius 45-degree and long radius 90-degree elbows wherever possible.
- Do not use 90-degree elbows "back to back" and do not use street elbows. Maintain a minimum 150mm (6 in.) straight section between elbows. Closely coupled and short radius elbows reduce the venting capacity. Figure 6 shows examples of vent pipe connections.
- DO NOT USE AN ELBOW AS A SUPPORT POINT.** Elbows are not designed to carry the weight of the venting system.

WATER HEATER MODEL	SUFFIX	VENT PIPE SIZE	PRESSURE SWITCH SETTING	* VENT MATERIAL (SCHEDULE 40)	MAXIMUM EQUIVALENT VENT LENGTH	MINIMUM EQUIVALENT VENT LENGTH
G/JW75	SNV, SPV	76mm (3 in.)	- 0.50 in. w.c. (-.124 kPa)	PVC**, CPVC	15.2m (50 ft.) + termination elbow with steel mesh screen	0.91m (3 ft.) + one 90° elbow + termination elbow with plastic screen

### Notes:

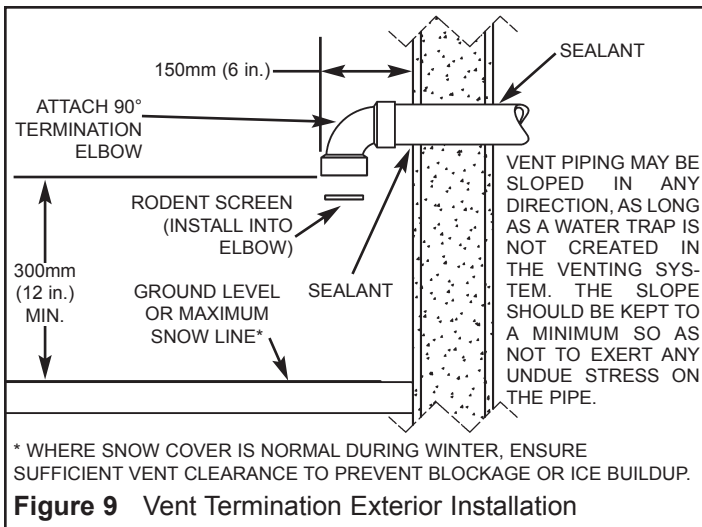
- Each 76mm (3 in.), 90° elbow is equivalent to 2.44m (8 ft.) of vent length.
- Each 76mm (3 in.), 45° elbow is equivalent to 1.22m (4 ft.) of vent length.
- Use long radius elbows. Minimum distance between elbows is 150mm (6 in.).
- Do not mismatch venting materials. \*Check local codes to determine which materials are allowed in your area.
- \*\*Pipe assembly adapter must be used with PVC venting material (see Figure 13).

**Table 2** Allowable Vent Lengths and Materials (Vert. and Horiz.).

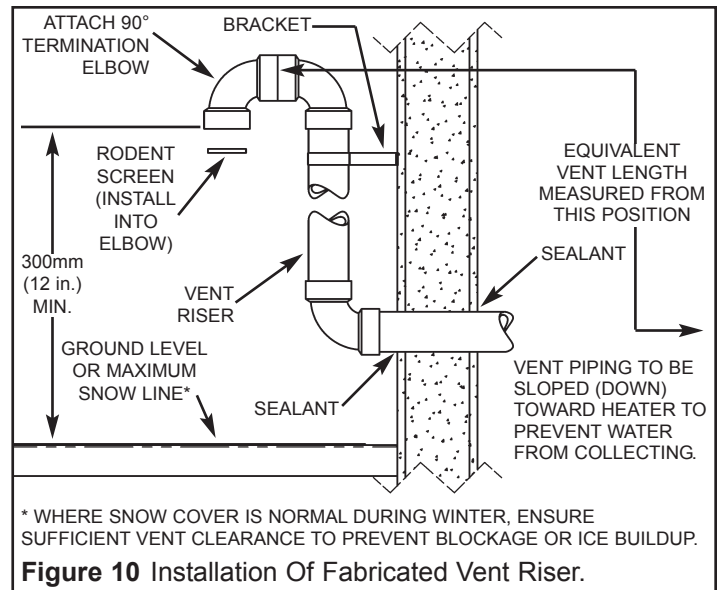


**Figure 8** General Venting Layout

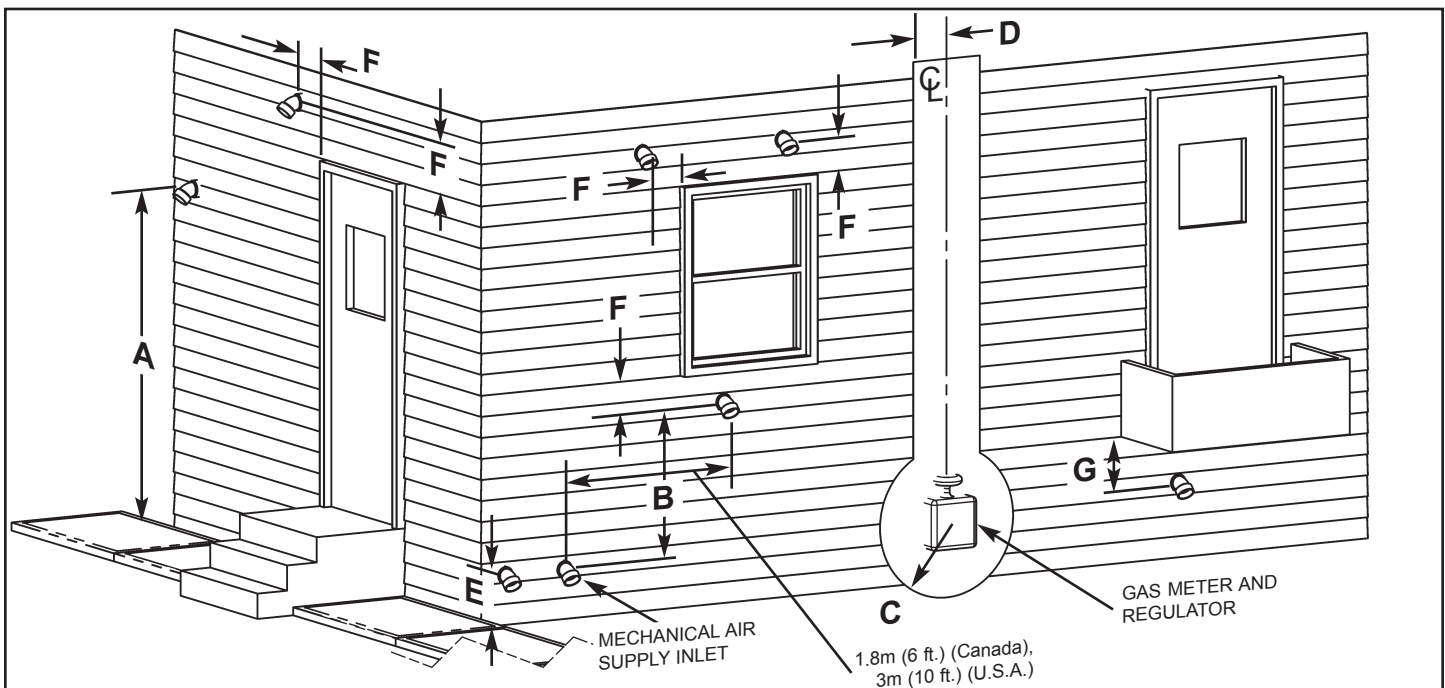




**Figure 9** Vent Termination Exterior Installation



**Figure 10** Installation Of Fabricated Vent Riser.



1. ("A") Minimum 2.1m (7 ft.) above a paved sidewalk or paved driveway that is located on public property.
2. ("B") Minimum 900mm (3 ft.) above any forced air or mechanical air supply inlet located within 1.8m (6 ft.) horizontally (Canada) or 3m (10 ft.) (U.S.A.).
3. ("C") Within 900mm (3 ft.) of any gas service regulator vent outlet.
4. ("D") Minimum 900mm (3ft) horizontally of the vertical centerline above the regulator vent outlet to a maximum vertical distance of 4.5m (15ft).
5. ("E") Minimum 305mm (1 ft.) above grade level or anticipated snow level.
6. ("F") Within 305mm (1 ft.) of any window or door that can be opened, of any non-mechanical air supply inlet or of the combustion air inlet of any other appliance.
7. ("G") Minimum 305mm (1 ft.) distance between the top of the vent termination and the underside of a veranda, porch or deck.
8. The manufacturer recommends the vent termination shall not be mounted directly above or within 900mm (3 ft.) horizontally from an oil tank or gas meter to avoid potential freeze-up or fouling from condensation.

**Figure 11** Horizontal Vent Terminal Installations

6. Calculate "Equivalent Vent Length" before starting. Do not exceed the values shown in Table 2. An example of how this length is determined is shown in Figure 8. The value from your calculations should also be used to determine which rodent screen to install into the vent termination elbow.
7. Measure the vent piping and cut to required lengths. Pipes must be cut at right angles and deburred to ensure a good smooth fit with sufficient overlap for the glue joints. Correct any interference conditions.
8. Provide support hangers for horizontal vent piping every 1.2m (4 ft.) to prevent sagging and stress. Provide a minimum of 3mm (1/8 in.) rise per 1.2m (4 ft.) of vent piping to ensure adequate drainage. Horizontal vent piping must not sag to form valleys where condensate may collect. Vertical venting shall be supported every 1.5m (5 ft.). Use appropriate support straps and vibration isolators (foam pads) on straight sections only. Do not use elbows as support points. Allow sufficient clearance for expansion and contraction of the venting system.
9. At the point where the vent pipe exits the building, cut a 90mm (3-1/2 in.) hole for 76mm (3 in.) venting.
10. Insert the vent piping through this hole and secure into position. Connect the vent pipe to the end termination elbow as shown in Figures 9-12.
11. Dry fit all vent pipes, elbows, connectors and fittings before joining any parts with solvent cement. PARTS MUST FIT WITHOUT STRESS OR BENDING OF ANY SECTION and each connection must overlap a minimum of 13mm (1/2 in.). Do not force fit any of the connections. Use only the appropriate solvent cement.
12. Install the properly sized rodent screen into the outlet elbow and secure with a small quantity of silicone sealant.
13. Do not seal the vent piping to the wall until the venting is properly connected to the blower assembly.

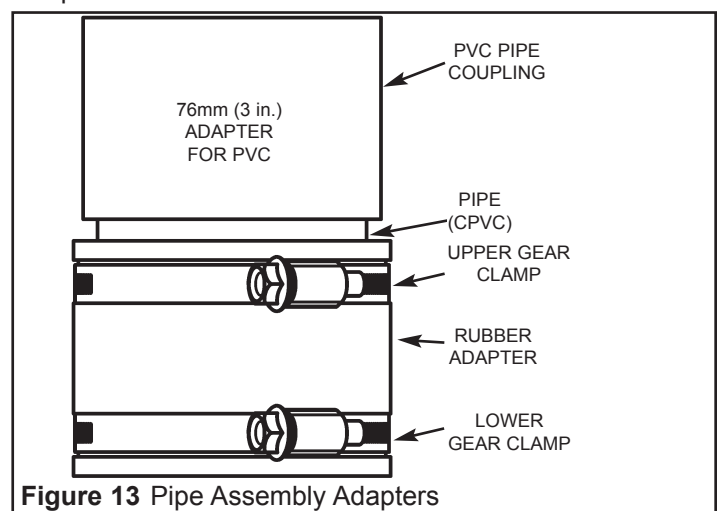
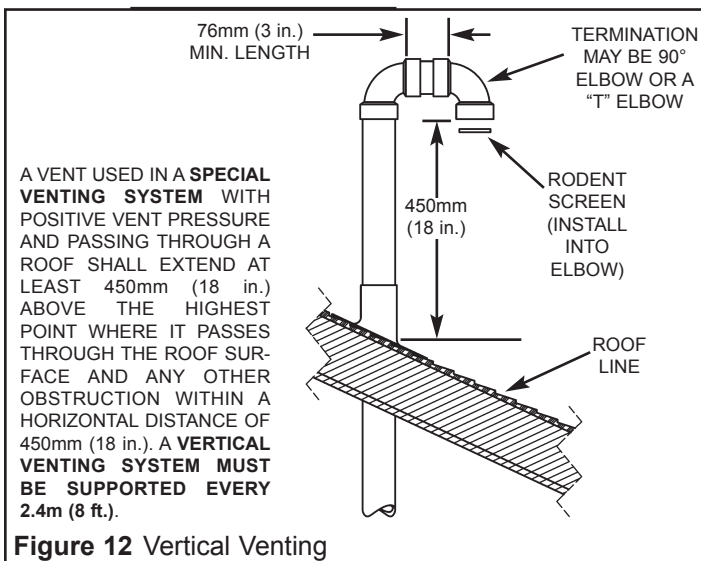
### Vent pipe connection to blower

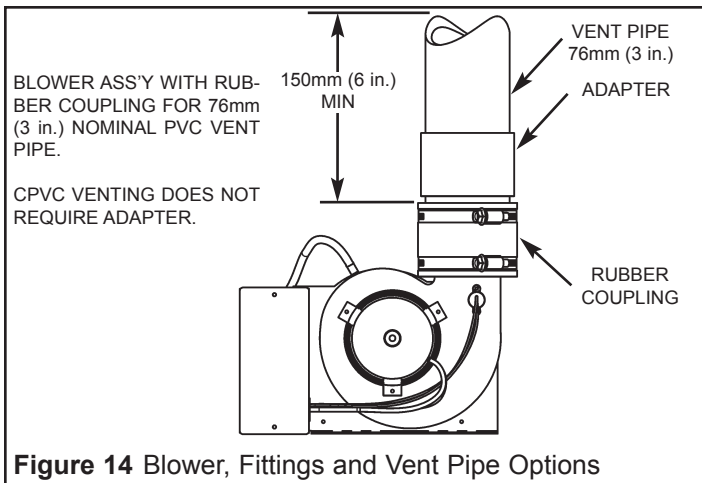
1. The plastic vent piping connects into the rubber coupling located on the top of the blower assembly. This coupling includes gear clamps to connect the venting to the blower. These connections must be properly seated and tightened to prevent the leakage of flue gases into the area. See Figures 13 & 14.
2. G/JW75 gallon heaters are supplied with a 76mm (3 in.) adapter for installations using PVC vent piping. This adapter must be used when using PVC piping. Securely attach the PVC adapter to the first section of PVC vent piping using the proper solvent cement before installation into the blower coupling.
3. G/JW75 gallon heaters using CPVC vent piping may be connected directly into the rubber coupling.
4. Clean and lightly sand the end of the CPVC plastic vent piping or PVC adapter that will connect into the rubber coupling.
5. Loosen the upper clamp on the rubber coupling and insert the sanded end of the CPVC vent piping or the PVC adapter a full 32mm (1-1/4 in.). Do not use glue or sealant in the rubber coupling. Check that there is no stress on the connection or the vent piping that may be caused by twisting or bending.
6. Tighten the upper clamp so that the vent piping is firmly secured in the coupling and is gas tight. Do not over tighten or cause distortion of any of the parts. Ensure that the bottom of the rubber coupling is firmly seated on the blower outlet and that the lower gear clamp is also secure. Check to ensure that there is no distortion or movement of the clamped assembly once it is completed.

### CAUTION:

#### Use of Solvent Cement and Primer

- Use only in well-ventilated areas.
- Do not use near flame or open fire.
- Use only the Solvent Cement and Primer appropriate for the venting material being used.
- Solvent cements for plastic pipe are flammable liquids and must be kept away from all sources of ignition.





**Figure 14** Blower, Fittings and Vent Pipe Options

**CAUTION:**

- Do Not Overtighten The Top And Bottom Gear Clamps Of The Rubber Coupling.
- Do Not Apply Solvent Cement Or Silicone To The Rubber Coupling Connection.

7. Complete the venting installation by sealing around the termination assembly where it passes through the outside wall, inside and out, with silicone or other suitable sealant.

**Water Supply Piping Installation**

Piping, fittings, and valves should be installed according to the installation drawing (Figure 15). A pressure-reducing valve and/or an expansion tank may be required for installations where the water pressure is high. The pressure-reducing valve should be located on the supply to the entire building in order to maintain equal hot and cold water pressure.

**Important:**

- Do not apply heat to the water fittings on the heater as they may contain nonmetallic parts. If solder connections are used, solder the pipe to an adapter before attaching the adapter to the hot and cold water fittings.
  - Some models may contain energy saving heat traps to prevent the circulation of hot water within the pipes. Do not remove the inserts within the heat traps.
  - Always use a proper grade of joint compound and be certain that all fittings are drawn up tight.
1. Install the water piping and fittings as shown in Figure 15. Connect the cold water supply to the fitting (3/4" NPT) marked "COLD" (or "C"). Connect the hot water supply to the fitting (3/4" NPT) marked "HOT" (or "H").
  2. The installation of unions in both the hot and cold water supply lines is recommended.
  3. The manufacturer of this water heater recommends installing a tempering valve in the domestic hot-water line as shown in Figure 16. These valves reduce the point-of-use water temperature by mixing cold and hot water. Contact a licensed plumber or the local plumbing authority.

4. If installing the water heater in a closed water system, install an expansion tank in the cold water line as specified under "Closed System/Thermal Expansion".
5. Install a shut-off valve in the cold-water inlet line. It should be located close to the water heater and be easily accessible. The owner/operator must be shown the location of this valve and be given instructions on how to use it to shut off the water to the heater.

**Filling the Water Heater**

Do not insert the power cord into the electrical receptacle until all the following steps have been completed.

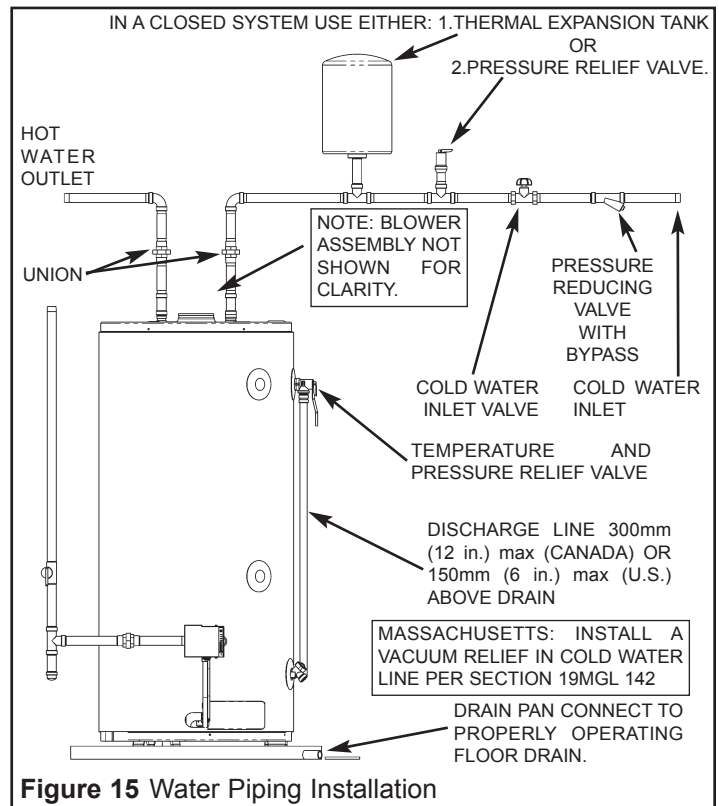
1. Make sure the drain valve is closed.
2. Open all hot-water faucets served by the system to allow air to escape from the tank.
3. Open the cold-water inlet valve.

**Note:** When filling, avoid water leakage. Do not allow the insulation of the water heater to get wet as water can reduce the effectiveness of the insulation.

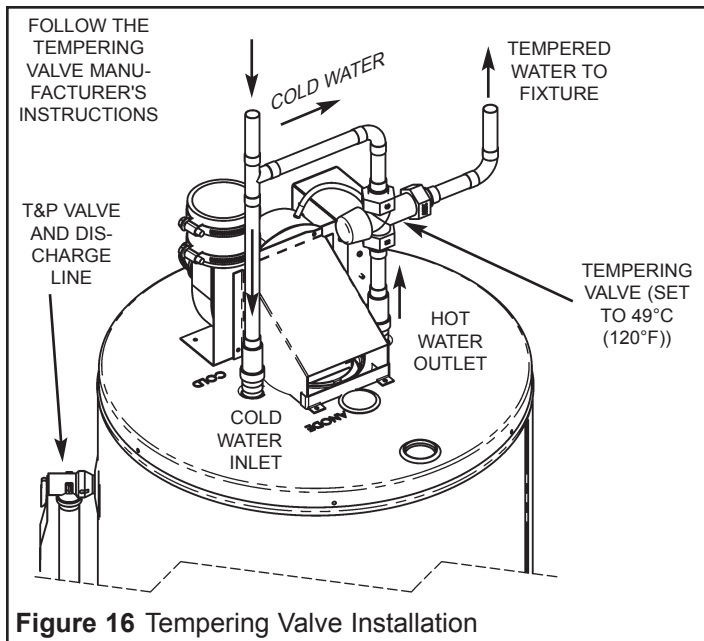
4. When an uninterrupted stream of water, without apparent air bubbles, flows from the open hot-water faucets, the tank is full.
5. Close the hot-water faucets and check the system for leaks. Repair as required and retest.

Please note the following:

- DO NOT** install this water heater with iron piping. The system should be installed only with piping that is suitable for potable (drinkable) water such as copper, CPVC, PEX or polybutylene. **DO NOT** use PVC water piping.
- DO NOT** use any pumps, valves, or fittings that are not compatible with potable water.
- DO NOT** use valves that may cause excessive restriction to water flow. Use full flow ball or gate valves only.



**Figure 15** Water Piping Installation

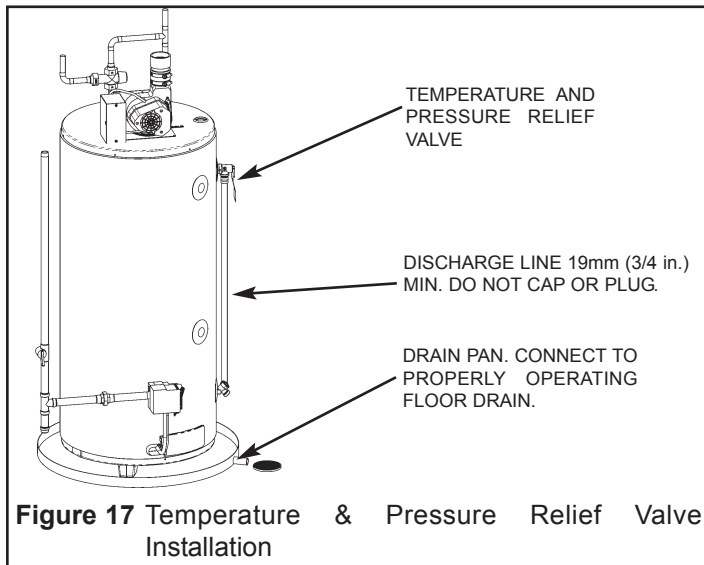


**Figure 16** Tempering Valve Installation

**DO NOT** use any lead based solder in potable water lines. Use appropriate tin-antimony or other equivalent material.  
**DO NOT** tamper with the gas control/thermostat, igniter or temperature and pressure relief valve. Tampering voids all warranties. Only qualified service technicians should service these components.  
**DO NOT** use with piping that has been treated with chromates, boiler seal, or other chemicals.  
**DO NOT** add any chemicals to the system piping which will contaminate the potable water supply.

### Closed System/Thermal Expansion

Periodic discharge of the temperature and pressure relief valve may be due to thermal expansion in a closed water supply system. The water utility supply meter may contain a check valve, backflow preventer or water pressure-reducing valve. This will create a closed water system. During the heating cycle of the water heater, the water expands causing pressure inside the water heater to increase. This may cause the temperature and pressure relief valve to discharge small quantities of hot water. To prevent this, it is recommended that a diaphragm-type expansion tank (suit-



**Figure 17** Temperature & Pressure Relief Valve Installation

able for potable water) be installed on the cold water supply line. The expansion tank must have a minimum capacity of 5.6 litres (1.5 US gallons) for every 190 litres (50 US gallons) of stored water and be rated at the working pressure of the water heater. Contact the local water supplier or plumbing inspector for information on other methods to control this situation.

**Important:** Do not plug or remove the temperature and pressure relief valve.

### Temperature and Pressure (T&P) Relief Valve

**WARNING**



#### Explosion Hazard

- If the temperature and pressure relief valve is dripping or leaking, have a licensed plumber repair it.
- Do not plug valve.
- Do not remove valve.
- Failure to follow these instructions can result in death or an explosion.

For protection against excessive pressures and temperatures, a temperature and pressure relief valve must be installed in the opening marked "T&P RELIEF VALVE" (see Figure 17). This valve must be design certified by a nationally recognized testing laboratory that maintains periodic inspection of the production of listed equipment or materials as meeting the requirements of the "**Standard For Relief Valves For Hot Water Supply Systems**", ANSI Z21.22/CSA 4.4. The function of the temperature and pressure relief valve is to discharge water in large quantities in the event of excessive temperature or pressure developing in the water heater. The valve's relief pressure must not exceed the working pressure of the water heater as stated on the data plate.

**Important:** Only a new temperature and pressure relief valve should be used with your water heater. Do not use an old or existing valve, as it may be damaged or not adequate for the working pressure of the new water heater. Do not place any valve between the relief valve and the tank.

#### The Temperature and Pressure Relief Valve:

- Must not be in contact with any electrical part.
- Must be connected to an adequate discharge line.
- Must not be rated higher than the working pressure shown on the data plate of the water heater.

#### The Discharge Line/Driptube:

- Must not be smaller than the pipe size of the relief valve or have any reducing coupling installed in the discharge line.




- Must not be capped, blocked, plugged or contain any valve between the relief valve and the end of the discharge line.
- Must terminate a maximum of 300mm (12 in.) (Canada) or 150mm (6 in.) (U.S.A.) above the floor.
- Must be capable of withstanding 121°C (250°F) without distortion.
- Must be installed to allow complete drainage of both the valve and discharge line.

## Electrical Supply

**⚠ WARNING**

**Electrical Shock Hazard**



- **Disconnect power before servicing.**
- **Replace all parts and panels before operating.**
- **Failure to do so can result in death or electrical shock.**

A three-wire cord and plug is provided with this water heater. The plug shall be connected into an electrically grounded, 120 VAC, 60 Hz, 15 Amps, fused receptacle.

**Important:** The electrical controls used inside the gas control/thermostat of this water heater are **polarity sensitive**. Ensure the electrical supply is connected correctly in the receptacle box. Failure to connect correctly will prevent the unit from functioning properly. Before performing any elec-

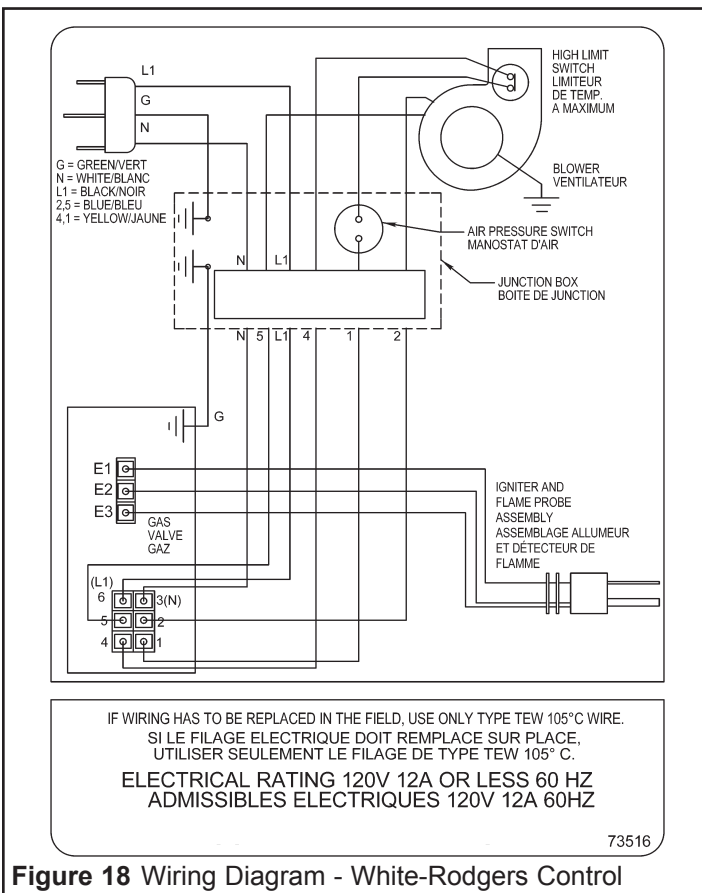


Figure 18 Wiring Diagram - White-Rodgers Control

**⚠ WARNING**

**When the unit is plugged in, 120VAC is present at the electric connections of the gas control/thermostat.**

trical service work, label all wires to avoid connection errors. If wiring has to be replaced, use only **TYPE TEW 105°C** wire, (except igniter wires). If there is a problem with igniter wires, replace igniter assembly in its entirety. In locations where a sump pump failure, flooding or exposure to water may be present, a ground fault receptacle is recommended. **Important:** Do not use an extension cord to connect the water heater to an electrical outlet.

- Ensure that the water heater and the outlet are properly grounded. Failure to properly ground the heater can prevent the unit from operating.
- Ensure that the water heater is installed in accordance with prevailing provisions of local codes, or, in the absence of such, the latest edition of "**Canadian Electrical Code**" (CAN/CSA C22.1), Part I (Canada) or "**National Electrical Code**" (NFPA 70) (U.S.A.).

Before applying power to the water heater, always make sure:

- The voltage and frequency correspond to that specified on the water heater wiring diagram.
- The electrical outlet has the proper overload fuse or breaker protection.

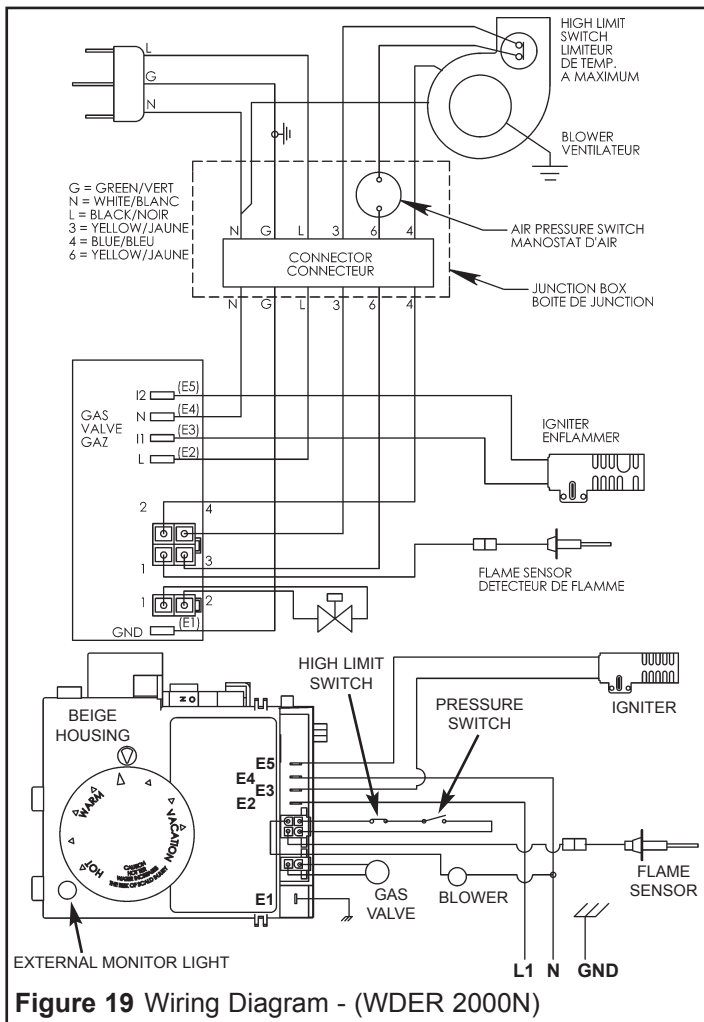
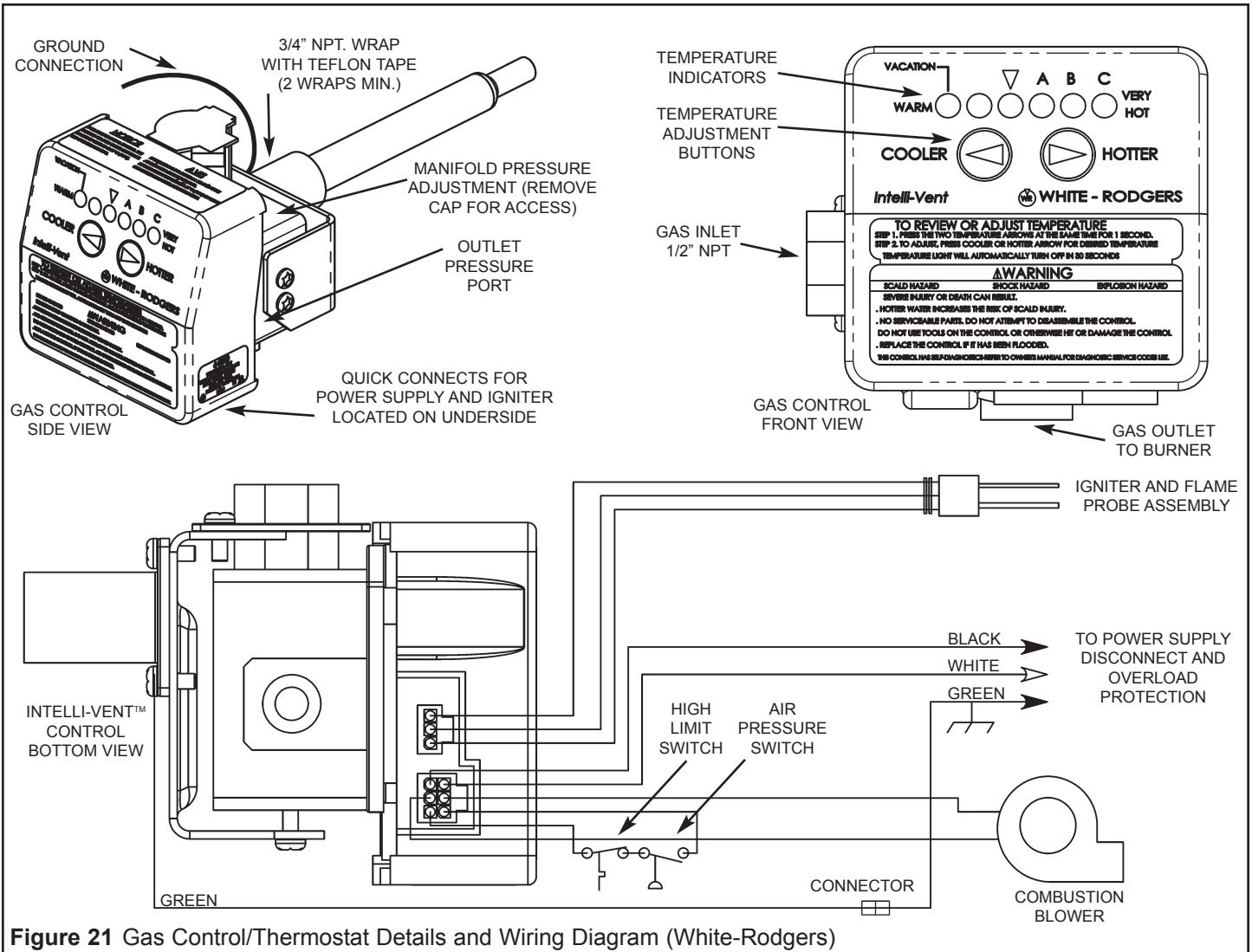
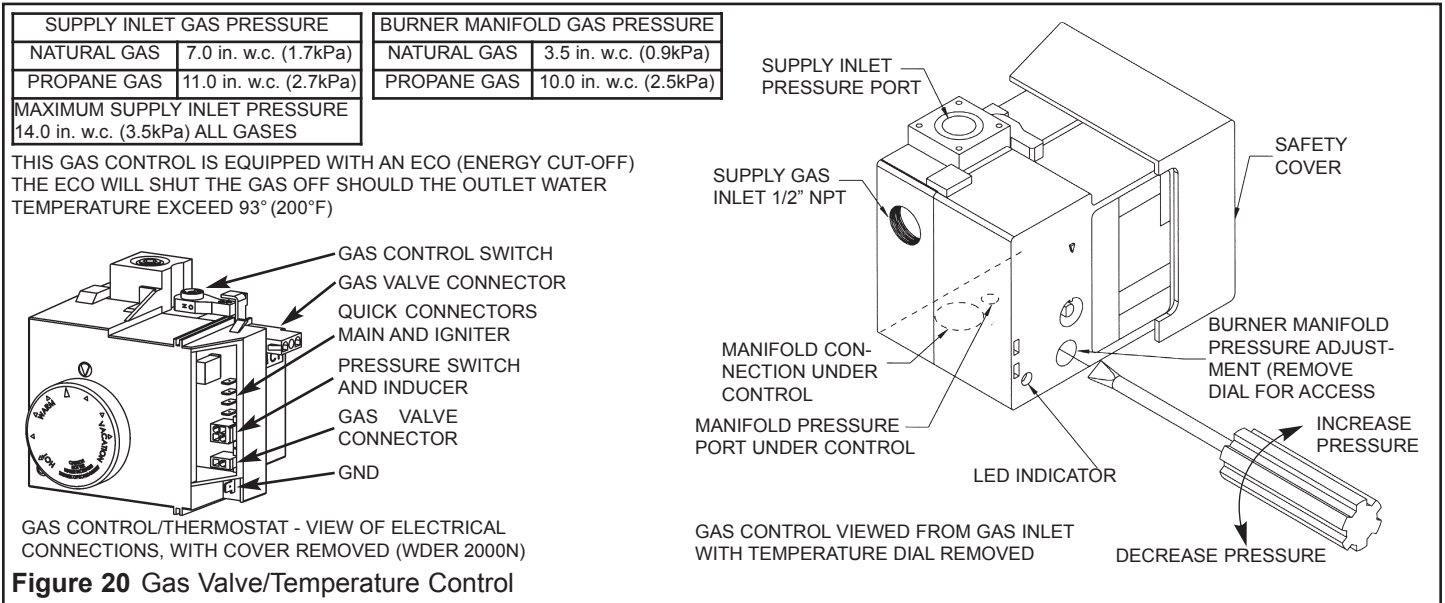


Figure 19 Wiring Diagram - (WDER 2000N)



- Fill the tank with water and check all connections for leaks. Open the nearest hot-water faucet and let it run for 3 minutes to purge the water lines of air and sediment and to ensure complete filling of the tank. The electrical power may then be turned on. Verify proper operation after servicing.

**Note:** Always reference the wiring diagram for the correct electrical connections.



## Installation Checklist

Check Here

1. Have the safety precautions described in this manual been implemented?
2. Does the gas piping conform to the recommendations of your Gas Utility Company?
3. Has the gas piping been tested?
4. Is the supply pressure correct?
5. Is the water heater connected to the correct gas supply as shown on the rating plate (Natural Gas/Propane)
6. Is the clearance between the water heater and combustible construction as per specifications?
7. Is the water piping correctly connected? Are you certain that there are no leaks?
8. Is the water heater filled with water?
9. Is the cold water supply valve open?
10. Is the vent pipe installed properly and are the vertical and horizontal runs properly supported?
11. Is the vent hood air intake opening unobstructed?
12. Is the T&P valve installed? Is the drain pipe from the T&P valve unobstructed?
13. Is a drain pan installed (if required) with a proper overflow pipe, directed to a drain?
14. Have you taken steps to prevent water damage in case of leaks?
15. Is the electric supply a 120V, electrically grounded, 15A fused, correct polarity circuit?
16. Does the area around the water heater have adequate ventilation?

**If the answer to all of the questions above is “Yes”, read the Operating Instructions and proceed with lighting the heater.**

## IV) OPERATING INSTRUCTIONS

### **⚠ CAUTION:**

**Read before proceeding. If you do not follow these instructions exactly, a fire or explosion may result, causing property damage, personal injury or loss of life.**

**This appliance is equipped with an ignition device that automatically lights the burner. Do not try to light manually with a match or flame.**

### **Temperature Regulation**

This water heater's intended purpose is to heat water. Hot water is needed for cleaning and sanitizing (bodies, dishes, clothing etc.). Untempered hot water can present a scald hazard. Depending on the time element and the people involved (adults, children, elderly, infirm etc.) scalding may occur at different temperatures.

It is recommended that lower temperatures be used to avoid the risk of scalding. It is further recommended that the water temperature be set for the lowest temperature that will satisfy your hot-water needs. This will also provide the most energy efficient operation of the water heater.

Short, repeated heating cycles caused by small water uses can cause temperatures at the point-of-use to exceed the thermostat setting by up to 17°C (30°F). This condition is referred to as "stacking". If you experience this type of use you should consider using lower temperature settings to reduce scald hazards.

Valves for reducing the point-of-use temperature by mixing cold and hot water are available.

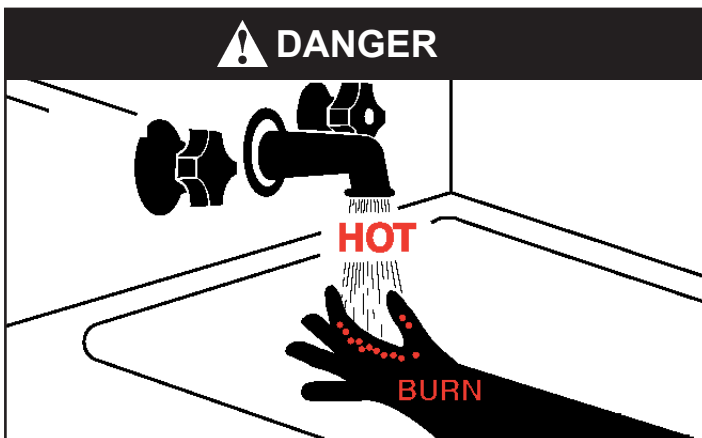
### **Mixing Valves**

**Hot water can scald:** Water heaters are intended to produce hot water. Water heated to a temperature that will satisfy space heating, clothes washing, dish washing, and other sanitizing needs can scald and permanently injure you upon contact. Some people are more likely to be permanently injured by hot water than others. These include the elderly, children, the infirm, and physically/mentally handicapped.

If any one using the hot water fits into one of these groups or if there is a provincial, state or local code requiring a certain temperature water at the hot water faucet, then you must take special precautions. In addition to using the lowest possible temperature setting that will satisfy your hot-water needs, a means such as a mixing valve, should be used at the hot-water faucets or at the water heater. Mixing valves are available at plumbing supply or hardware stores. Follow manufacturer's instructions for installation of these valves. Before changing the factory settings on the thermostat, read the "Temperature Regulation" section in this manual.

### **⚠ WARNING**

**Never allow small children to use a hot-water faucet, or to draw their own bath water. Never leave a child or impaired person unattended in a bathtub or shower. Scald burns can result.**



Water temperature over 52°C (125°F) can cause severe burns instantly or death from scalds.

Children, disabled and elderly are at highest risk of being scalded.

Feel water before bathing or showering.

Temperature limiting valves are available.

### **⚠ WARNING**

**Scald burns occur in under one second with 71°C (160°F) water, which the thermostat will deliver if the temperature is set at "VERY HOT". Lower settings of the temperature will reduce the risk of scald and will reduce your fuel bill.**

### **⚠ WARNING**

#### **Risk of scalding**

**Hot water can produce third degree burns**  
in 6 seconds at .....60°C (140°F)  
in 30 seconds at .....54°C (130°F)  
in 5 minutes at .....49°C (120°F)

## Lighting Instructions (Robertshaw)

### FOR YOUR SAFETY READ BEFORE OPERATING

**WARNING:** If you do not follow these instructions exactly, a fire or explosion may result causing property damage, personal injury or loss of life.

- A. This appliance does not have a pilot. It is equipped with an ignition device which automatically lights the burner. Do not try to light the burner by hand.
- B. **BEFORE OPERATING** smell all around the appliance area for gas. Be sure to smell next to the floor because some gas is heavier than air and will settle on the floor.

#### WHAT TO DO IF YOU SMELL GAS

- Do not try to light any appliance.
  - Do not touch any electric switch; do not use any phone in your building.
  - Immediately call your gas supplier from a neighbor's phone. Follow the gas supplier's instructions.
  - If you cannot reach your gas supplier, call the fire department.
- C. Use only your hand to push in or turn the gas control switch. Never use tools. If the switch will not push in or turn by hand, do not try to repair it, call a qualified service technician. Force or attempted repair may result in a fire or explosion.
- D. Do not use this appliance if any part has been under water. Immediately call a qualified service technician to inspect the appliance and to replace any part of the control system and any gas control which has been under water.

### POUR VOTRE SÉCURITÉ, LISEZ AVANT DE METTRE EN MARCHÉ


**ATTENTION:** Quiconque ne respecte pas à la lettre les instructions dans la présente notice risque de déclencher un incendie ou une explosion entraînant des dommages, des blessures ou la mort.

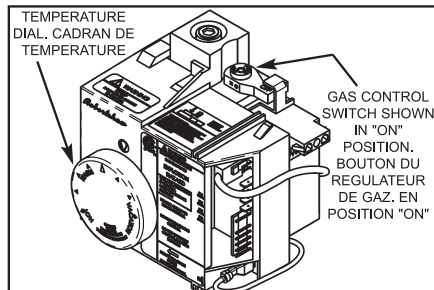
- A. Cet appareil ne comporte pas de veilleuse. Il est muni d'un dispositif d'allumage qui allume automatiquement la brûleur. Ne tentez pas d'allumer le brûleur manuellement.
- B. **AVANT DE FAIRE FONCTIONNER**, reniflez tout autour de l'appareil pour détecter une odeur de gaz. Reniflez près du plancher, car certains gaz sont plus lourds que l'air et peuvent s'accumuler au niveau du sol.

#### QUE FAIRE SI VOUS SENTEZ UNE ODEUR DE GAZ:


- Ne pas tenter d'allumer d'appareil.
  - Ne touchez à aucun interrupteur; ne pas vous servir des téléphones se trouvant dans le bâtiment.
  - Appelez immédiatement votre fournisseur de gaz depuis un voisin. Suivez les instructions du fournisseur.
  - Si vous ne pouvez rejoindre le fournisseur, appelez le service des incendies.
- C. Ne poussez ou tournez le manette d'admission du gaz qu'à la main; ne jamais utiliser d'outil. Si la manette reste coincée, ne pas tenter de le réparer; appelez un technicien qualifié. Le fait de forcer la manette ou de la réparer peut déclencher une explosion ou un incendie.
- D. N'utilisez pas cet appareil s'il a été plongé dans l'eau, même partiellement. Faites inspecter l'appareil par un technicien qualifié et remplacez toute partie du système de contrôle et toute commande qui ont été de plongés dans l'eau.

### OPERATING INSTRUCTIONS

1. **STOP!** Read the safety information above (to the left) on this label.
2. Set the thermostat to the lowest setting.
3. Turn off all electric power to the appliance.
4. This appliance is equipped with an ignition device which automatically lights the burner. Do not try to light the burner by hand.
5. Press gas control switch. It will automatically turn to "OFF."
6. Wait five (5) minutes to clear out any gas. Then smell for gas, including near the floor. If you then smell gas, **STOP!** Follow "B" in the safety information above (to the left) on this label. If you do not smell gas, proceed to the next step.
7. Turn gas control switch counterclockwise  to "ON".
8. Turn on all electric power to the appliance.
9. Set thermostat dial to desired setting.
10. If the appliance will not operate, follow the instructions "To Turn Off Gas To Appliance" and call your service technician or gas supplier.



### INSTRUCTIONS DE MISE EN MARCHÉ

1. **ARRÊTEZ!** Lisez les instructions de sécurité sur la portion supérieure (à gauche) de cette étiquette.
2. Réglez le thermostat à la température la plus basse.
3. Coupez l'alimentation électrique de l'appareil.
4. Le present appareil est muni dispositif d'allumage qui allume automatiquement la brûleur. **NE PAS TENEZ D'ALLUMER LA BRÛLEUR MANUELLEMENT.**
5. Tourner le bouton du regulateur de gaz vers la droite jusqu'à la position "OFF".
6. Attendre cinq (5) minutes pour laisser échapper tout le gaz. Reniflez tout autour de l'appareil, y compris près du plancher, pour détecter une odeur de gaz. Si vous sentez une odeur du gaz, **ARRÊTEZ!** Passez à l'étape "B" des instructions de sécurité sur la portion supérieure (à gauche) de cette étiquette. S'il n'y a pas d'odeur de gaz, passez à l'étape suivante.
7. Tourner le bouton du regulateur de gaz vers la gauche  jusqu'à la position "ON".
8. Mettez l'appareil sous tension.
9. Réglez le thermostat à la température désirée.
10. Si l'appareil ne se met pas en marche, suivez les instructions intitulées "Comment Couper L'admission De Gaz De L'appareil" et appelez un technicien qualifié ou le fournisseur de gaz.

### TO TURN OFF GAS TO APPLIANCE

1. Set the thermostat dial to lowest setting.
2. Turn off all electric power to the appliance if service is to be performed.
3. Press gas control switch. It will automatically turn to "OFF."

### COMMENT COUPER L'ADMISSION DE GAZ DE L'APPAREIL

1. Réglez le thermostat à la température la plus bas.
2. Coupez l'alimentation électrique de l'appareil s'il faut procéder à l'entretien.
3. Tourner le bouton du regulateur de gaz vers la droite a la position "OFF".

**CAUTION:**  
 Read before proceeding. If you do not follow these instructions exactly, a fire or explosion may result, causing property damage, personal injury or loss of life.

**Gas Control/Thermostat**

This heater may be equipped with a Robertshaw WDER 2000N gas control/thermostat and a hot-surface igniter. This control is a combination gas valve, thermostat and ignition controller for use on this power vented water heater. The valve contains a micro-controller that supervises the ignition sequence and monitors the temperature settings and operation of the heater.

**This heater is equipped with a hot-surface ignition system that automatically ignites the burner. Do not attempt to light this heater manually with a match or flame-producing device.**

**Putting the Heater into Service**

1. Turn the manual gas shut-off valve for the heater to the "ON" position.
2. Turn the gas control switch to "ON".
3. Follow the Lighting Instructions (Robertshaw) given on the side of the water heater and also depicted in this manual. See also "Gas Supply", "Water Heater Operation" and "Sequence of Operation".

**Temperature Adjustment**

The temperature dial is adjusted to its lowest temperature position when shipped from factory.

- The temperature of the water can be selected by adjusting the temperature dial located on the front of the control (see Figure 20).
- The large arrow position of the thermostat is the preferred starting point.
- Each division on the thermostat dial represents a 3°C (5°F) water temperature change.

**Note:** To avoid scald injury, set the control to the lowest setting that will supply your hot-water needs.

There is a hot-water scald potential if the thermostat is set too high. In households with children, disabled or the elderly, select a lower temperature setting. Tempering valves (mixing valves) for reducing point-of-use water temperatures are available and may be required by your local authority. Consult a licensed plumber or your local plumbing authority.

**WARNING**  
**Risk of scalding**  
 Hot water can produce third degree burns  
 in 6 seconds at .....60°C (140°F)  
 in 30 seconds at .....54°C (130°F)  
 in 5 minutes at .....49°C (120°F)

**Heater Shutdown**

1. Turn the thermostat dial to the lowest setting.
2. If the heater is running let it shut down first.
3. Turn off all electrical power to the heater or unplug the power cord from the receptacle.
4. a) For WDER 2000N controls, press the gas control switch located on the top of the control. It will automatically turn to the "OFF" position.
5. Turn the manual gas supply valve to the water heater to the "OFF" position.

**Water Heater Operation**

Figure 22 shows the water heater's sequence of operation when a call for heat is initiated. The ignition control module will attempt to light the burner three times. If the ignition control does not detect ignition it will enter lockout mode and flash the error code.

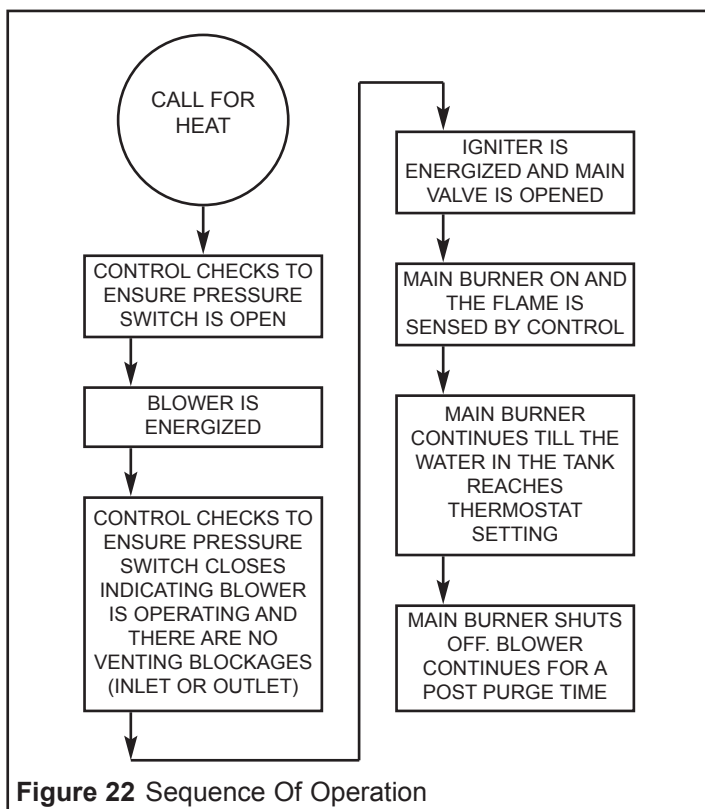


Figure 22 Sequence Of Operation



# Lighting Instructions (White-Rodgers Intelli-Vent™)

## FOR YOUR SAFETY READ BEFORE OPERATING

**WARNING:** If you do not follow these instructions exactly, a fire or explosion may result causing property damage, personal injury or loss of life.

- A. This appliance does not have a pilot. It is equipped with an ignition device which automatically lights the burner. Do not try to light the burner by hand.
  - B. BEFORE OPERATING smell all around the appliance area for gas. Be sure to smell next to the floor because some gases are heavier than air and will settle on the floor.
- WHAT TO DO IF YOU SMELL GAS**
- Do not try to light any appliance.
  - Do not touch any electric switch; do not use any phone in your building.
  - Immediately call your gas supplier from a neighbour's phone. Follow the gas supplier's instructions.
  - If you can't reach your gas supplier, call fire department.
- C. Use only your hand to push in the gas control buttons. Never use tools. If the control buttons will not push in by hand, do not try to repair them, call a qualified service technician. Force or attempted repair may result in a fire or explosion.
  - D. Do not use this appliance if any part has been under water. Immediately call a qualified service technician to inspect the appliance and to replace any part of the control system and any gas control which has been under water.

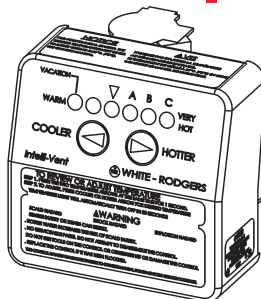
## POUR VOTRE SÉCURITÉ LISEZ AVANT DE METTRE EN MARCHÉ

**AVERTISSEMENT:** Tout manquement aux présentes directives peut causer un incendie ou une explosion pouvant se traduire par des dommages matériels, des blessures ou la mort.

- A. Cet appareil ne comporte pas de veilleuse. Il est muni d'un dispositif d'allumage automatique du brûleur. Ne tentez pas d'allumer le brûleur manuellement.
  - B. AVANT D'UTILISER L'APPAREIL: humez l'air tout autour de l'appareil afin d'y déceler une éventuelle odeur de gaz. Assurez-vous de sentir au niveau du sol, car certains gaz sont plus lourds que l'air et s'accumulent au niveau du sol.
- QUE FAIRE SI VOUS SENTEZ UNE ODEUR DE GAZ:**
- Ne pas tenter d'allumer d'appareil.
  - Ne touchez à aucun interrupteur; ne pas vous servir des téléphones se trouvant dans le bâtiment.
  - Appelez immédiatement votre fournisseur de gaz depuis un voisin. Suivez les instructions du fournisseur.
  - Si vous ne pouvez joindre le fournisseur, appelez le service des incendies.
- C. Ne vous servez que de vos mains pour appuyer sur les boutons de réglage du gaz. N'utilisez jamais d'outil. Si vous n'arrivez pas à actionner les boutons avec vos doigts, ne tentez pas de les réparer. Faites plutôt appel à un technicien d'entretien qualifié. Le recours à la force ou une tentative de réparation infructueuse pourrait causer un incendie ou une explosion.
  - D. N'utilisez pas cet appareil s'il a été plongé dans l'eau, même partiellement. Faites inspecter l'appareil par un technicien qualifié et remplacez toute partie du système de contrôle et toute commande qui ont été plongés dans l'eau.

## LIGHTING INSTRUCTIONS

1. STOP! Read the safety information above (to the left) on this label.
2. This appliance is equipped with an ignition device which automatically lights the burner. Do not try to light the burner by hand.
3. Turn off all electrical power to the appliance.
4. Wait five (5) minutes to clear out any gas. Then smell for gas, including near the floor. If you then smell gas, STOP! Follow "B" in the safety information above (to the left) on this label. If you do not smell gas, proceed to the next step.
5. Make sure that both the inner and outer doors are in place. These doors are located where the burner tube enters the water heater at the bottom. Both doors must be in place for safe operation. Fill water heater with water.
6. Plug in water heater to power source.
7. Set gas control to the desired temperature by:
  - holding down both the "COOLER" and "HOTTER" temperature adjustment buttons at the same time for one second and release,
  - press the "COOLER" or "HOTTER" button repeatedly until the desired temperature is indicated by the LEDs (see instruction manual for temperature setting indicators).
8. If the appliance will not operate, follow the instructions "TO TURN OFF GAS TO APPLIANCE" and call your service technician or gas supplier.



## INSTRUCTIONS DE MISE EN MARCHÉ

1. ARRÊTEZ! Lisez les directives de sécurité sur la portion supérieure droite de cette étiquette.
2. Le brûleur de cet appareil est muni d'un dispositif d'allumage automatique. Ne tentez pas d'allumer le brûleur manuellement.
3. Coupez l'alimentation électrique de l'appareil.
4. Afin de laisser se dissiper tout gaz ayant pu s'accumuler, attendez cinq (5) minutes. Humez l'air tout autour de l'appareil, y compris près du plancher, afin d'y déceler une éventuelle odeur de gaz. Si vous sentez une odeur de gaz, ARRÊTEZ! Passez au point "B" des directives de sécurité présentées ci-dessus. Si vous ne détectez pas d'odeur de gaz, passez à la prochaine étape.
5. Assurez-vous que le couvercle d'accès externe soit en place et que la glissière interne soit refermée. Le couvercle et la glissière se trouvent là où le tube du brûleur se dirige sous le chauffe-eau. On doit laisser le couvercle et la glissière en place pour que l'appareil fonctionne de façon sécuritaire. Procédez au remplissage du chauffe-eau.
6. Alimentez le chauffe-eau en électricité.
7. Pour régler la commande du gaz à la température désirée:
  - Appuyez simultanément sur les boutons d'ajustement "COOLER" et "HOTTER" pendant une seconde, et relâcher,
  - Appuyez de façon répétitive sur les boutons "COOLER" et "HOTTER", jusqu'à ce que la température désirée s'affiche (le manuel contient des directives sur le choix de la température de consigne).
8. Si l'appareil ne se met pas en marche, suivez la directive "COMMENT COUPER L'ADMISSION DE GAZ DE L'APPAREIL" ci-dessous et appelez un technicien qualifié ou le fournisseur du gaz.

## TO TURN OFF GAS TO APPLIANCE

Set thermostat to vacation or un-plug water heater for servicing. The Intelli-Vent™ control will remember the temperature setting. Turn off gas and water.

## COMMENT COUPER L'ADMISSION DE GAZ DE L'APPAREIL

Ajustez le thermostat à "Vacation" ou débranchez le chauffe-eau. La commande du gaz Intelli-Vent™ retournera à la même température de consigne lors du rebranchement de l'appareil. Fermez les robinets des canalisations du gaz et d'eau.

73514

**CAUTION:**  
Read before proceeding. If you do not follow these instructions exactly, a fire or explosion may result, causing property damage, personal injury or loss of life.

### Gas Control/Thermostat

Alternatively, this heater may be equipped with the White-Rodgers Intelli-Vent™ gas control/thermostat and a hot-surface igniter. This control is a combination gas valve, thermostat and ignition controller for use on this power vented water heater. The valve contains a microcomputer that supervises the ignition sequence and monitors the temperature settings and operation of the heater. The computer also monitors the flammable vapour safety features of this heater.

This heater is equipped with a White-Rodgers Silicon Nitride Igniter system that automatically ignites the burner. Do not attempt to light this heater manually with a match or flame-producing device.

### Putting the Heater into Service

1. Turn the manual gas shut-off valve for the heater to the "ON" position.
2. Follow the Lighting Instructions (White-Rodgers) given on the side of the water heater and also depicted in this manual. See also "Gas Supply", "Water Heater Operation" and "Sequence of Operation".
3. Upon start up all the indicator lights on the front of the control will come on and then turn off. This indicates that the control has completed a self-diagnostic test and is ready for operation.

**Note:** If any of the indicator lights remain on, this indicates a system fault that needs correcting. See the "System Error Codes" and "Troubleshooting Guide (White-Rodgers)" for corrective action.

### Temperature Adjustment

The control is adjusted to its lowest temperature setting (approximately 21°C (70°F)) when shipped from factory.

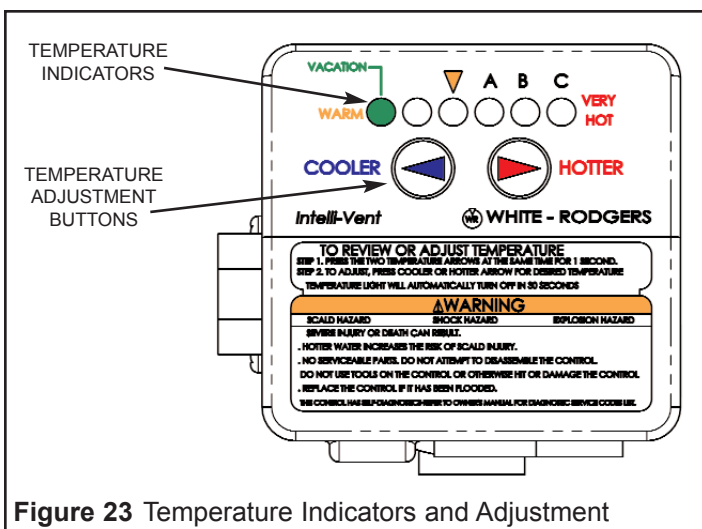


Figure 23 Temperature Indicators and Adjustment

The temperature of the water can be selected by using the temperature adjustment buttons on the front of the gas control (see Figure 18) as follows:

1. "Wake up" the temperature indicators by holding down both the "COOLER" and "HOTTER" temperature adjustment buttons at the same time for one second. One or two of the temperature indicators will light up. After 30 seconds, if no other buttons are pushed, the control will go back to "Sleep" mode and both buttons will again have to be pressed to see the water temperature setting.
2. Release both of the temperature adjustment buttons.
3. The current water temperature setting will be indicated. See Table 3 for an explanation of the temperature indicators.
  - a. To decrease the temperature press and release the "COOLER" button once. The temperature indicators will now display the new temperature setting. Press and release the "COOLER" button until you have reached the desired setting.
  - b. To increase the temperature press and release the "HOTTER" button once. The temperature indicators will now display the new temperature setting. Press and release the "HOTTER" button until you have reached the desired setting.

**Note:** Holding down the button will not continue to lower the setting. The button must be pressed and released for each temperature change desired.

**Note:** To avoid scald injury, set the control to the lowest setting that will supply the hot water for your needs. Refer to Table 3 to determine the approximate temperature setting, and the approximate time for scald injury at that temperature.

4. When you have completed setting the control wait 30 seconds for the temperature indicators go off and the control to enter "Sleep" mode.

DISPLAY	APPROXIMATE TEMPERATURE °C (°F)
	21°C (70°F) (VACATION)
	43°C (110°F)
	46°C (115°F)
	49°C (120°F)
	52°C (125°F)
	54°C (130°F)
	57°C (135°F)
	60°C (140°F)
	63°C (145°F)*
	65°C (150°F)*
	71°C (160°F)*

\* These settings are not available on Hi-input models.

Table 3 Temperature Settings

## ⚠ WARNING

**Scald burns occur in under one second with 71°C (160°F) water, which this thermostat will deliver if the temperature is set at “VERY HOT”. Lower settings of the temperature will reduce the risk of scald and will reduce your fuel bill.**

**Note:** All the temperature indicators will be off during normal operation. If any time you see the indicators on, there may be a system error and you should consult the “Troubleshooting Guide” section of this document, or contact a trained service professional.

There is a hot-water scald potential if the thermostat is set too high. In households with children, disabled or the elderly, select a lower temperature setting. Valves for reducing point-of-use temperature by mixing hot and cold water are available. Consult a licensed plumber or the local plumbing authority.

### Heater Shutdown

1. Turn off all electrical power to the heater or unplug the power cord from the receptacle.
2. Turn the manual gas supply valve to the water heater to the “OFF” position.








### System Error Codes

The computer inside the gas control monitors the ignition sequence, temperature settings and overall operation of the heater. If any of these parameters does not operate properly the computer will shut down the water heater and flash an error code. See the “Intelli-Vent™ System Error Codes” and “Troubleshooting Guide” to diagnose the problem before attempting corrective action. See also “Resettable Lockout”.

### Intelli-Vent™ System Error Codes

SYMPTOM	POSSIBLE CAUSE(S)	CORRECTIVE ACTION
<p style="text-align: center;">Error 1</p>	An open earth ground circuit to the ignition system.	<ol style="list-style-type: none"> <li>1. Check that the earth ground conductor is properly connected at the fuse box or breaker panel and the water heater.</li> <li>2. Check that the grounding conductors on the water heater are properly connected and secure.</li> </ol>
<p style="text-align: center;">Error 2</p>	The self diagnostic test detected a wiring error, reversed polarity or a high resistance to earth ground.	<ol style="list-style-type: none"> <li>1. Check for proper connection of the line neutral and line hot wires.</li> <li>2. Check that the appliance is securely connected to earth ground.</li> </ol>
<p style="text-align: center;">Error 3</p>	The pressure switch remained closed longer than 5 seconds after the call for heat began. Blower does not start.	<ol style="list-style-type: none"> <li>1. The pressure switch wiring is incorrect.</li> <li>2. The pressure switch is defective and must be replaced.</li> </ol>
<p style="text-align: center;">Error 4</p>	The pressure switch remained open longer than 5 seconds after the combustion blower was energized.	<ol style="list-style-type: none"> <li>1. The pressure switch wiring is incorrect.</li> <li>2. The pressure switch tubing is not connected correctly.</li> <li>3. Obstructions or restrictions in the water heater air intake or exhaust flue.</li> <li>4. Check the high temperature limit switch.</li> </ol>
<p style="text-align: center;">Error 5</p>	The self diagnostic test has detected an error in the hot-surface igniter circuit.	<ol style="list-style-type: none"> <li>1. Check that all wiring is correct and secure.</li> <li>2. Disconnect the igniter connector and measure the igniter resistance with an accurate ohmmeter between pins 1 and 2. Resistance should be between 11.5 and 18.8 ohms. If the reading is incorrect, replace the hot-surface igniter.</li> <li>3. If the above checks are good, replace the control.</li> </ol>
<p style="text-align: center;">Error 6</p>	The maximum number of ignition retries or recycles has been reached and the system is in lockout for an hour. Cycle the power to the water heater off and on to reset.	<ol style="list-style-type: none"> <li>1. Ensure the igniter is positioned correctly.</li> <li>2. Ensure the voltage to the water heater is 115-125 VAC.</li> <li>3. Clear any obstructions or restrictions in the water heater air intake or exhaust flue.</li> </ol>

**Table 4** Intelli-Vent™ System Error Codes.

SYMPTOM	POSSIBLE CAUSE(S)	CORRECTIVE ACTION
Error 7 	The self-diagnostic test found a problem with the gas valve driver circuit.	<ol style="list-style-type: none"> <li>1. Cycle power to the water heater "OFF" for 10 seconds and then back "ON".</li> <li>2. If the above step did not clear the error, the control must be replaced.</li> </ol>
Error 8 	The self-diagnostic test has detected a problem with the internal microcomputer.	<ol style="list-style-type: none"> <li>1. Cycle the external power "OFF" for 10 seconds and then back "ON".</li> <li>2. If the above step does not clear the error, the control must be replaced.</li> </ol>
Error 9 	The self-diagnostic test has detected a problem with the internal circuit.	<ol style="list-style-type: none"> <li>1. Cycle the external power "OFF" for 10 seconds and then back "ON".</li> <li>2. If the above step does not clear the error, the control must be replaced.</li> </ol>
Error 10 	Flame signal sensed out of proper sequence.	<ol style="list-style-type: none"> <li>1. Insure flame sensor ceramic insulator is not cracked.</li> <li>2. Turn power off for 10-20 seconds, and then on again to clear the error code.</li> <li>3. Replace the control.</li> </ol>
Error 11 	The high temperature thermal cutoff is open.	<ol style="list-style-type: none"> <li>1. Turn the power off for 10-20 seconds then on again to clear the error code.</li> <li>2. Replace the control.</li> </ol>
Error 12 	The self-diagnostic test has detected one of the temperature adjust buttons stuck closed.	<ol style="list-style-type: none"> <li>1. Make sure that there are no objects leaning against the front of the control.</li> <li>2. Lightly press and release each of the buttons once.</li> <li>3. If the above actions do not clear the error, the control will continue to regulate water temperature at the last setting, but you will not be able to change settings unless you replace the control.</li> </ol>
Error 13 	The self-diagnostic test has detected that the water temperature sensor is either open or short circuited.	<ol style="list-style-type: none"> <li>1. Turn the power off for 10-20 seconds then on again to clear this error code.</li> <li>2. If no wiring problems are found the control must be replaced.</li> </ol>

**Table 4 (cont'd)** Intelli-Vent™ System Error Codes.



## V) OPERATION

### Performance Checks

#### Burner Manifold Pressure

The burner operates at a manifold gas pressure of 3.5 in. w.c. (0.9kPa) for natural gas and 10.0 in. w.c. (2.5kPa) for propane gas. A 1/8" NPT port is provided on the gas valve control for connection to a gauge to measure the pressure (See Figure 20). The control valve has an internal pressure regulator. Do not confuse the manifold pressure with the supply inlet pressure. Return port plug upon completion of tests.

#### Checking Input

Never exceed input shown on the rating plate. Ask your gas supplier for the heating value of the gas you are using. Check the input by "clocking" the gas meter. Make sure no other appliances are operating when the test is being done. To ensure accuracy, clock enough gas so that the time is greater than 60 seconds. Use the following formula to check input. Check that your gas pressures are as previously stated.

Input in BTU/Hour =

$$\frac{\text{Gas Heating Value} * \times \text{Cubic Feet/Meters clocked}}{\text{Seconds clocked}/3600}$$

\*Gas Heating Value in BTU/cubic feet or cubic meters

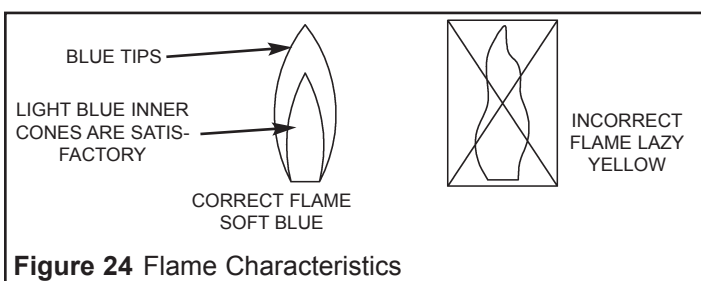
1 cubic meter = 35.31 cubic feet

#### Checking burner flame

Superflue™ Water Heaters uses a cast iron burner. Access the burner by lifting off the outer gas door and sliding open the inner door located at the bottom of the water heater.

- For units with cast iron burners, the flame presentation should be as shown in Figure 24. Adjustment is possible by changing the air shutter position on the burner inlet. If the flame needs adjusting, loosen the two screws and move the shutter (see Figure 25). If it is too far open, the flame will lift or will be noisy; if it is closed too far, the flame will be luminous and yellow. Once proper flame is obtained, tighten the screws to secure the air shutter.

**Important:** Always return the burner doors to their original position.



## VI) SERVICE AND MAINTENANCE

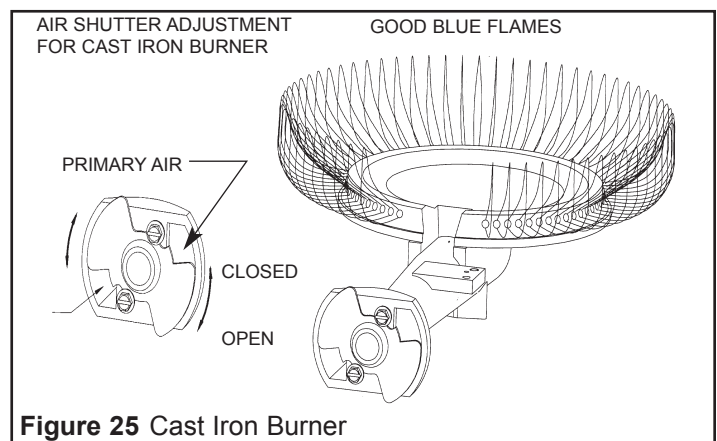
This section describes the routine service instructions to properly maintain your heater and venting system.

#### Not Enough or No Hot Water

- Check that the water heater is operational.
- Check that the thermostat is set high enough.
- Check that you have not just run out of hot water due to heavy demand. If this is a routine problem, it may indicate an under-sized water heater.
- Have your gas company check input rate and water heater operation.
- The ECO may have tripped open (LED indicator on constantly). See ECO below.

#### Energy Cut-off Control (ECO)

This water heater is equipped with a control that has a built in ECO (Energy Cut-Off). The ECO will shut the gas off, should the outlet water temperature exceed 93° (200°F). If the ECO has tripped, the entire gas control must be replaced. For gas control replacement, contact your local gas utility, or a qualified service technician. The replacement control must be an identical model to the control that has been removed.





### **Water is Too Hot**

- Check that thermostat setting is not too high.
- Water heaters used for dishwashers, space heating or laundry facilities generally require higher temperatures than domestic use. Install anti-scald tempering valves as instructed in the safety warnings.
- See also “Temperature Regulation”.
- If the problem persists, contact your dealer or gas supplier.

### **Hot Water Odour**

On occasion, and depending on your location, hot water may develop a strong odour. This can be especially problematic in regions where the water contains some sulphur, which results in hot water having a “rotten egg” smell.

If this occurs, drain the system completely, flush thoroughly and refill. If the problem persists, the anode rod may need to be changed from magnesium to one made of aluminum. In certain cases chlorination and flushing of the water heater may be required. Contact you dealer or water supplier.

### **Discoloured Water**

- Water rich in iron or other minerals can produce red or brown staining. Heating water generally worsens this situation.
- Black water can be an indication of organic contaminants in the water supply. This can be problematic in areas where the water is obtained from surface or contaminated sources. Organic particles can develop bacterial growth, causing potential health hazards. Contact your water supplier for proper filtration or water conditioning equipment. For bacterial problems contact your local health authority. See also “Hot Water Odour”
- A sudden appearance of rusty water can indicate the anode rod has been depleted. The remaining steel core wire may be corroding, releasing iron particles into the water. Inspect and replace as necessary.

### **Water Heater Makes Noise**

- During start up or under heavy use, condensation can drip on the burner causing a sizzling noise as the water is evaporated. This is normal and will stop once temperatures rise.
- Sediment, sand or scale can accumulate resulting in “rumbling” noises. Water heaters need to be flushed regularly to minimize buildup. Severe accumulations can cause premature failure of the water heater and will void the warranty.
- Vent piping can vibrate if it is not supported properly. Ensure hangers and vibration isolators are properly installed.

### **Extended Non Use Service**

Hydrogen gas can be produced by water heaters in service but on standby for long periods of time (generally two weeks or more). See safety warnings in the front of the manual. Hydrogen gas is extremely flammable. Use caution in opening faucets.

### **Condensation**

Water vapor in the flue gases can condense on the cooler surfaces of the water heater, especially during the start of a cold tank, during heavy use, or if the water heater is undersized. Condensation can also be produced in the vent piping if the vent piping becomes chilled (e.g. going through unheated areas) or if the dilution air is very cold.

Condensation may give the false impression that there is a tank leak as significant amounts can drip out of the bottom of the water heater. Once the water heater is operating at normal temperatures tank condensation should disappear. See “Venting” section for dealing with condensation in the vent piping.

### **Anode Maintenance**

Your water heater has been supplied with an anode rod that protects the tank from corrosion. As the rod works, it slowly dissolves over time and must be replaced when it becomes totally consumed. Depending on water conditions, an anode can last several years. Most localities treat their water, which can have significant effect on the life of your heater. Water conditioning such as over softening can accelerate the rate at which the anode rod is consumed. Rapid depletion can leave a heater unprotected causing a premature failure. As with any water heater, it is good practice to check the anode annually to see if it needs replacing (Figure 1, Item No. 15).

#### **To inspect or change an anode:**

- turn off the water heater
- close the cold inlet supply valve
- open a hot water tap supplied by the heater.
- drain the water heater enough to empty the piping system.
- using a 1 1/16” socket, remove anode and inspect or replace as required.
- refill system with water and restore water heater to operation.

**Warning:** Operating a water heater without an actively working anode rod will void the warranty.

### **Tank Flushing**

Periodically (monthly) drain approximately 8 liters (2 gallons) from the tank through the drain valve. This will minimize sediment buildup on the tank bottom.

**Caution:** WATER WILL BE HOT.

If scale removal is being considered, contact your dealer for proper procedures. DO NOT USE HYDROCHLORIC ACID (HCL) based cleaners. Thoroughly flush after any chemical cleaning.

## Relief Valve Check

**WARNING**



### Explosion Hazard

- If the temperature and pressure relief valve is dripping or leaking, have a licensed plumber repair it.
- Do not plug valve.
- Do not remove valve.
- Failure to follow these instructions can result in death or an explosion.

Inspect the relief valve annually to ensure proper operation. This involves opening the valve to check that it is flowing freely and that there are no blockages. Provide a bucket or drainage for the expelled water. Lift the lever and let it snap shut. The water should stop instantly.

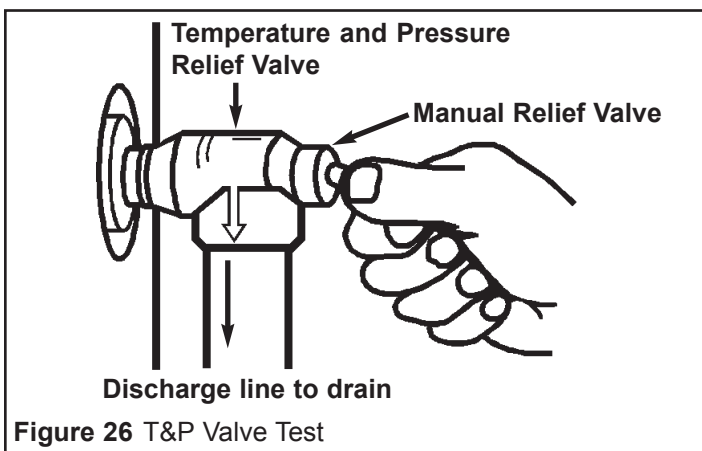


Figure 26 T&P Valve Test

**Warning:** WATER WILL BE HOT and water flow can be forceful. If the valve does not function properly, it must be replaced.

In systems where the relief valve discharges periodically, this may be due to thermal expansion or to a thermostat that is operating at too high a temperature. In a closed water system, an expansion tank may be required. Contact your local plumbing inspector. For a malfunctioning thermostat, contact your gas supplier.

Manually operate the temperature and pressure relief valve at least once a year to make sure it is working properly (see Figure 26). To prevent water damage, the valve must be properly connected to a discharge line that terminates at an adequate drain. Standing clear of the outlet (discharged water may be hot), slowly lift and release the lever handle on the temperature and pressure relief valve to allow the valve to operate freely and return to its closed position. If the valve fails to completely reset and continues to release water, immediately shut off the manual gas valve and the cold-water inlet valve and call a qualified service technician.

## Vent Maintenance

- Inspect the venting system periodically (minimum twice annually) to make certain that the vent passageways, vent terminal and blower assembly are free and unobstructed. Ensure that any condensate is draining freely. Clean as necessary.
- Inspect the vent piping, elbows and connections for signs of stress cracking or deterioration. Make certain the venting is free to move and that all pipe hangers and isolation supports are properly positioned and securely attached. Replace any broken components and rectify any installation problems.
- In areas that have a high level of airborne particulate (e.g. lint, sawdust, process smoke, laundry areas, etc.) inspection and cleaning may need to be done more frequently. This can be problematic, especially where condensation is present, as particles can adhere to the venting surfaces. Particles, especially lint can also clog the vent blower wheel. These conditions can reduce the venter performance resulting in nuisance failures.
- Inspect the flue collector area for signs of corrosion. This can be an indication of contaminated air, a wet environment, poor burner set up, or high levels of condensation occurring at the flue collector. Determine and correct any poor operating conditions.

## Burner Maintenance

Annually inspect the burner and combustion chamber area to ensure that no debris has fallen on the burner and that no foreign material has found its way into the combustion chamber. Observe the flame for proper operation. ALWAYS KEEP THE AREA AROUND THE WATER HEATER CLEAR OF COMBUSTIBLE MATERIALS. NEVER RESTRICT THE FLOW OF AIR TO THE WATER HEATER.

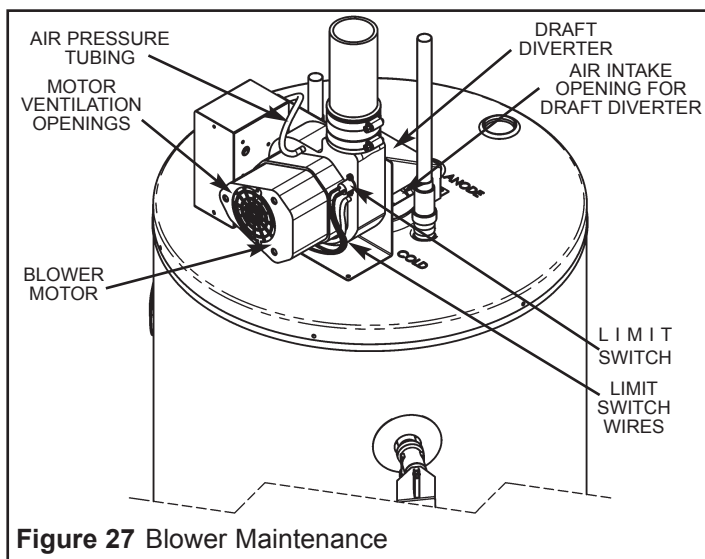


Figure 27 Blower Maintenance

## VII) COMBO HEATING

This section serves as a guide for the installation and use of “Combo” heating systems utilizing a domestic water heater that has been specifically approved for such use. It is written for those knowledgeable in the required trades and professionals involved in the design and installation of Combo Heating Systems.

**It is the responsibility of the installer/designer to follow all applicable codes to ensure the effectiveness and safety of the installation.**

### System Requirements

The following requirements must be met for the installation of Combo Heating Systems:

1. All components used for the distribution of water in the heating loop must be suitable for potable water. These include all piping, fittings, solder and fluxes, pumps for circulation of water, valves, etc.
2. The water heater must not be connected to a hydronic heating system that has been used previously.
3. No boiler treatment chemicals of any kind shall be introduced into the system.
4. The Combo System components must be selected and sized to meet and maintain the total calculated demands for both domestic service hot water and space heating requirement. The sizing and installation must be performed in accordance with good engineering practice such as “ASHRAE Handbooks”, HRAI, “Hydronics Institute Manuals”, CGA B149, NFPA 54, ANSI Z223.1, CSA F280, National/Provincial Building Codes, CSA C22.1, ANSI/NFPA 70, CSA B51 and/or codes having jurisdiction.
5. The air handler (fan coil) and/or the circulating pump in a baseboard hydronic loop will require a dedicated 120V circuit. This must be provided and identified for this purpose.
6. All piping between the water heater and the air handler or hydronic baseboard loop must be adequately insulated to reduce heat loss.
7. If the local jurisdiction requires a back-flow preventer in the cold water line, an expansion tank of adequate size must be installed.
8. "Combo" Heating Systems require higher water temperatures than other applications. When the system is used to supply water for Combo Heating applications, a means, such as mixing valve, must be installed to temper the water in order to reduce scald hazard potential (see Figures 28 & 29).

## Installation

The heating mode may be one of the following options:

- A A fan coil (air handler)
- B A hydronic baseboard (finned tube) loop/In-floor heating

### Fan Coil

The following is a list of requirements for the installation of the heating loop to the water heater (see Figure 28).

1. Install shut-off valves and unions so that the water heater can be isolated from the heating module should servicing of the water heater become necessary.
2. Install a drain valve at the lowest point of the heating loop so that water can be drained from the heating module without affecting the water heater.
3. If the air handler does not have a venting means at the highest point of the piping arrangement, install an air bleed at the highest point of the plumbing arrangement.

## Baseboard Radiator Heating

The following is a list of requirements for the installation of the heating loop to the water heater (see Figure 29).

1. Install shut-off valves and unions so that the water heater can be isolated from the heating module should servicing of the water heater become necessary.
2. A drain valve must be installed at the lowest point of the heating loop so that water can be drained from the heating module without affecting the water heater.
3. Install air bleed valves at the highest points to purge air from the system.

## Maintenance

The installation and maintenance of the water heater must follow all of the instructions described in sections I to VII of this manual. Heater failure that is a result of the heating system is not covered by warranty.

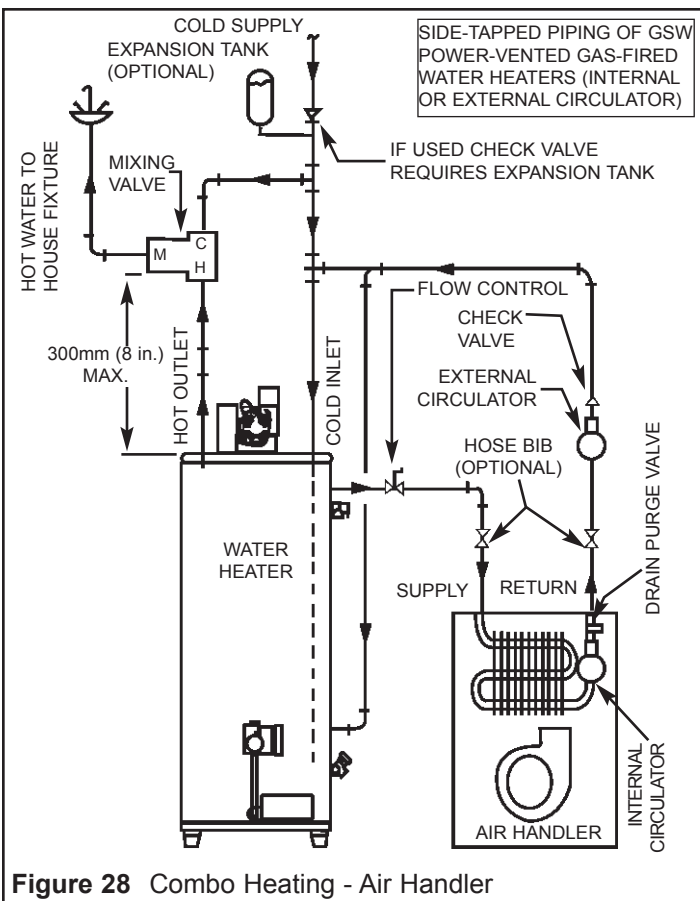


Figure 28 Combo Heating - Air Handler

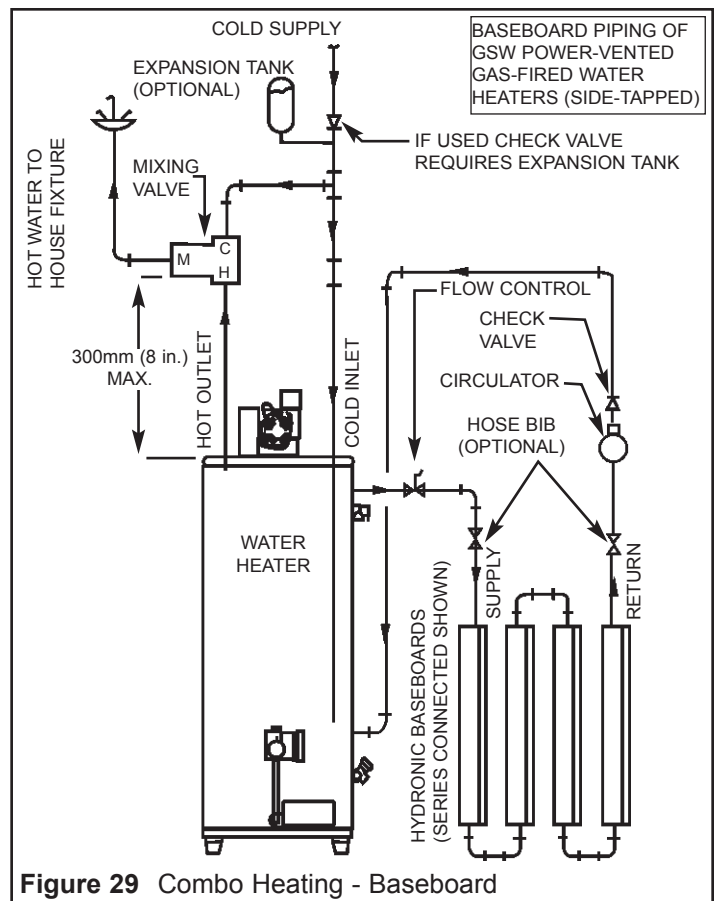


Figure 29 Combo Heating - Baseboard

## VIII) TROUBLESHOOTING GUIDE

### SUPERFLUE™

**Note:** Troubleshooting must be done by qualified service personnel familiar with the start up and check out procedure. See also Sequence Of Operation (Figure 22).

STEP	CHECK THAT:	POSSIBLE PROBLEM	CORRECTION
1.	All steps on installation check list have been followed	Incomplete installation	Review installation check list
2.	Gas supply matches heater rating plate	Wrong gas / Wrong heater model	Match gas to heater type
3.	Gas supply is "ON" Gas control is "ON"	No gas	- Turn on gas supply - Check and adjust pressure accordingly
4.	Heater is plugged into properly fused circuit	- No power - Incorrect polarity at power source	- Check power supply - Check fuses - Plug in heater
5.	Thermostat is set to call for heat	Thermostat set too low	Rotate dial to higher setting
6.	Gas control performs start up diagnostic, LED flashes 3-4 times	- Gas control may be damp from excessive humidity or condensation. Steady red LED light may show on - Continuous flashing red light indicates safety lockout. - Steady red LED light, possible Energy Cut-Off (ECO) failure from excessive water temperature, power surge or internal failure	- Disconnect power, remove safety cover and dry control see Figure 20 - Disconnect power, wait 10 sec. and re-energize - Continue troubleshooting to find source of failure - Replace control*
7.	Power vent blower starts	- Incorrect or broken wire connection - Blower defective - Air pressure switch stuck closed	- Correct wiring conditions - Replace blower* - Replace pressure switch*
8.	Air pressure switch closes (with sufficient vent draft)	- Vent piping blocked or frozen - Vent piping too long - Blower wheel clogged - Pressure tube pinched or broken - Faulty pressure switch	- Remove blockage - Reduce vent length - Clean wheel of dirt and debris - Correct condition - Replace pressure switch*
9.	High limit switch closed (with normal operating temperatures)	- Switch opened from excessive vent temperature due to over-firing, flue collector blockage or insufficient air supply - Faulty switch	- Check and adjust firing rate - Remove blockages - Correct air supply conditions - Replace switch*
10.	Igniter energizes	- No power to igniter - Flashing red LED light from: - debris fallen on igniter or flame rod - igniter cracked or broken - Air pressure switch open - High limit switch open	- Check power supply to control and igniter - Disconnect power, wait for 10 sec. and re-energize - Clear away debris - Replace igniter - See step 8 - See step 9



STEP	CHECK THAT:	POSSIBLE PROBLEM	CORRECTION
11.	Gas valve opens, main burner comes on	<ul style="list-style-type: none"> <li>- Poor electrical connection on control</li> <li>- Flashing red LED light from: insufficient gas pressure</li>   <li>- flame rod out of position</li>   <li>- flame rod oxidized (low signal) or broken (no signal)</li>   <li>- Safety shut down by pressure switch or high limit switch. Blower continues to run but heater will not operate</li> </ul>	<ul style="list-style-type: none"> <li>- Check power supply and terminal connections</li> <li>- Correct gas supply and burner manifold pressures</li>   <li>- Reposition rod (rod tip should be level with or slightly above the top of the burner)</li> <li>- Unplug flame sensor wire and connect micro amp meter. Current should be greater than 0.7 micro amps. Remove oxidation (if present) with steel wool. Replace rod if broken or signal insufficient.</li> <li>- See above information on pressure switch or high limit switch</li> <li>- Check for debris that have may entered combustion chamber or venting</li> </ul>

# White-Rodgers Intelli-Vent™

SYMPTOM	POSSIBLE CAUSE(S)	CORRECTIVE ACTION
BLOWER WILL NOT START.	<ol style="list-style-type: none"> <li>1. No Power to unit.</li> <li>2. Thermostat setting too low.</li> <li>3. Defective air pressure switch (must be open at start-up before blower is energized).</li> <li>4. Defective blower.</li> <li>5. Disconnected or loose wire.</li> <li>6. Control locked-out.</li> </ol>	<ol style="list-style-type: none"> <li>1. Plug in power cord, check fuses/supply voltage.</li> <li>2. Increase thermostat temperature setting.</li> <li>3. Replace air pressure switch.</li> <li>4. Replace blower.</li> <li>5. Repair/reconnect wires.</li> <li>6. Reset – determine cause of lockout.</li> </ol>
BLOWER RUNS CONTINUOUSLY.	<ol style="list-style-type: none"> <li>1. Air pressure switch not closing due to insufficient draft - check for:               <ol style="list-style-type: none"> <li>a) vent piping blocked,</li> <li>b) piping length too long,</li> <li>c) frozen vent termination,</li> <li>d) clogged/dirty blower.</li> </ol> </li> <li>2. Disconnected, torn or blocked pressure sensing tubing from air pressure switch to blower housing.</li> <li>3. Air pressure switch not closing due to defective switch.</li> <li>4. High limit switch open due to excessive vent temperature or defective switch.</li> </ol>	<ol style="list-style-type: none"> <li>1. Determine cause of insufficient draft. Check draft with manometer at pressure switch (refer to Table 2 for minimum acceptable draft settings).               <ol style="list-style-type: none"> <li>a) remove blockage,</li> <li>b) reduce vent length/increase vent size,</li> <li>c) clear termination of snow/ice,</li> <li>d) clean blower wheel.</li> </ol> </li> <li>2. Reconnect or replace pressure sensing tubing.</li> <li>3. Replace defective pressure switch.</li> <li>4. Determine cause of overheating check for: overfiring, insufficient air supply, high ambient air temperature (once activated high limit must be replaced).</li> </ol>
HOT SURFACE IGNITER NOT GLOWING FOLLOWING WARM-UP PERIOD.	<ol style="list-style-type: none"> <li>1. 120VAC polarity reversed at 120VAC outlet receptacle.</li> <li>2. Defective hot surface igniter.</li> <li>3. Defective Control.</li> </ol>	<ol style="list-style-type: none"> <li>1. Reverse polarity at 120VAC outlet receptacle.</li> <li>2. Replace igniter (Check for 120VAC across I1 &amp; I2, Robertshaw only).</li> <li>3. Replace control.</li> </ol>
CONTROL LOCKED-OUT.	<ol style="list-style-type: none"> <li>1. No gas supply.</li> <li>2. Gas control switch in “OFF” position.</li> <li>3. Insufficient gas supply.</li> <li>4. Incorrect manifold gas pressure.</li> <li>5. Incorrect gas type.</li> <li>6. Defective igniter/loose or disconnected wire.</li> <li>7. Improperly positioned, dirty, or defective flame rod/loose or disconnected wire.</li> <li>8. Burner orifice clogged.</li> <li>9. Blocked water heater flue.</li> <li>10. Defective control.</li> </ol>	<ol style="list-style-type: none"> <li>1. Check/turn on gas supply.</li> <li>2. Turn control switch to “ON” position (Robertshaw only).</li> <li>3. Ensure correct supply pressure for gas type (Nat Gas 7.0 in. w.c. (1.74 kPa)) (Propane 11.0 in. w.c. (2.74 kPa)).</li> <li>4. Check/adjust for correct manifold gas pressure (NG 3.5 in. w.c.(0.87 kPa)), (Propane 10.0 in. w.c. (2.49 kPa)).</li> <li>5. Ensure correct gas type for water heater model.</li> <li>6. *Replace defective igniter/reconnect wiring.</li> <li>7. *Reposition, clean, or replace defective flame rod/reconnect wiring.</li> <li>8. Remove obstruction.</li> <li>9. Remove blockage/clean flue.</li> <li>10. Replace Control.</li> </ol> <p>* See Figure 1</p>
CONTROL LOCKED-OUT. *SOLID GREEN LED.	<ol style="list-style-type: none"> <li>1. Internal control fault.</li> <li>2. ECO failure – excessive water temperature.</li> <li>3. Excessive humidity/damp environment.</li> </ol>	<ol style="list-style-type: none"> <li>1. Replace control.</li> <li>2. Replace control.</li> <li>3. Allow control to dry.</li> </ol>

**\*Note:** Items that are damaged by power surges, improper gas pressures, freezing, flooding or improper handling, installation or over-firing are not covered by warranty.

GSW Water Heating  
599 Hill Street West  
Fergus, ON Canada N1M 2X1  
Should you have any questions please  
Email us at [techsupport@gsw-wh.com](mailto:techsupport@gsw-wh.com)  
or  
Visit our websites: [www.gsw-wh.com](http://www.gsw-wh.com)  
or  
[www.johnwoodwaterheaters.com](http://www.johnwoodwaterheaters.com)  
or  
Call our Technical Support line at  
1-888-GSW-TECH (479-8324)

### **INSTALLATION RECORD**

This water heater is protected by a multi-year warranty against leaks.  
Record key data here for future reference and prompt service

INSTALLED BY:	
INSTALLATION DATE:	
LOCATION OF GAS SHUT-OFF VALVE:	
MODEL NUMBER:	
SERIAL NUMBER:	

## LIMITED WARRANTY

See Rating Label Serial Number prefix for  
Warranty Code.

Warranty Code: P R S T U V W Y  
Warranty Years: 3 5 6 7 8 9 10 12

### RESIDENTIAL STORAGE TANK TYPE WATER HEATER FOR INSTALLATION IN A SINGLE FAMILY DWELLING

#### A. WHO IS COVERED.

GSW WATER HEATING AND ITS SUPPLIERS, (herein collectively referred to as "Manufacturer") warrants only to the original consumer purchaser (hereinafter "Owner") of the water heater, within the boundaries of continental United States, or Canada, or their territories, so long as he or she continuously occupies the single family dwelling in which this water heater is initially installed for the period specified below. This warranty is not transferable. This warranty is reduced to one year if the water heater is used in a commercial, or industrial application, or if the water heater is used to supply more than one dwelling unit. Consumers must retain point-of-sale proof of purchase to validate warranty entitlement.

#### B. WHEN IT IS COVERED.

The water heater is warranted only when it is installed, operated and maintained in accordance with the printed instructions accompanying the water heater. The water heater shall/must be installed in such a manner that, if the tank or any connection thereto should leak, the resulting flow of water will not cause damage to the area in which it is installed. The water heater's temperature and pressure relief valve must be piped to the nearest drain to avoid damage in the event the valve is actuated. For detailed instructions read the manual accompanying the water heater and review drawings in the manual.

#### C. WHAT THE MANUFACTURER WILL DO AND THE PERIOD OF COVERAGE.

- The Inner Tank.** If the inner tank leaks within the warranty period shown in the table at the top of this page after the original installation, Manufacturer will furnish a new water heater of Manufacturer's then prevailing comparable model. If industry standards, regulatory changes, product improvements or product obsolescence prohibits Manufacturer from furnishing an identical model replacement water heater under this warranty, the Owner will be furnished with a new water heater of comparable capacity; however, the Owner will be charged for the additional value of the item(s) which Manufacturer has incorporated in the replacement water heater. A prior authorization number must be obtained from the Manufacturer before replacing the water heater. This warranty is limited to one replacement water heater at the original installation site.
- Component Part.** If any component part other than the inner tank proves to Manufacturer's satisfaction to be defective in material or workmanship within one (1) year, the Manufacturer will furnish the Owner with a replacement for the defective part(s). This warranty is limited to one replacement component part for each original part.
- Return of Defective Water Heater and Component Parts.** Manufacturer reserves the right to examine the alleged defect in the water heater or component part(s), and it will be the Owner's obligation (See paragraph D.5) to return the water heater and/or component part(s) to the Manufacturer.
  - When returning a water heater it must include all component parts and the data plate label.
  - When returning component part(s), they must be individually tagged and identified with the water heater's product number, model number, serial number, date of purchase and date of installation.
  - THERE ARE NO WARRANTIES WHICH EXTEND BEYOND THE DESCRIPTION ON THE FACE HEREOF. THIS EXPRESS WARRANTY IS, WHERE PERMITTED BY LAW, IN LIEU OF AND EXCLUDES AND REPLACES ALL OTHER CONDITIONS, WARRANTIES, GUARANTEES, REPRESENTATIONS, OBLIGATIONS OR LIABILITIES OF THE MANUFACTURER OF ANY NATURE OR KIND, EXPRESS OR IMPLIED, HOWEVER ARISING (WHETHER BY CONTRACT, CONDUCT, STATEMENT, STATUTE, NEGLIGENCE, PRINCIPLES OF MANUFACTURER'S LIABILITY, OPERATION OF LAW OR OTHERWISE) WITH RESPECT TO THE UNIT OR ITS FITNESS FOR A PARTICULAR PURPOSE, MERCHANTABILITY, INSTALLATION, OPERATION, REPAIR OR REPLACEMENT. THE MANUFACTURER EXPRESSLY DISCLAIMS ANY AND ALL IMPLIED WARRANTIES. IN NO EVENT WILL THE MANUFACTURER'S LIABILITIES EXCEED THE COST OF THE DEFECTIVE PART(S) OR UNIT.

#### D. WHAT THIS WARRANTY DOES NOT COVER.

- The Unit must not be installed where water damage can result from a leak, while provision(s) shall be made for directing any water escaping from the Unit, to a properly operating drainpipe. As all units of this type may eventually leak, you must protect against any potential water damage. The Manufacturer accepts no responsibility for such damage, nor any incidental or consequential loss, nor damage(s) related thereto, suffered by the Owner of the Unit nor by any third party.
- Manufacturer shall not be liable under this warranty and this warranty shall be void and have no effect if the following events occur:
  - The water heater or any of its component parts have been subject to misuse, alteration, neglect or accident; or
  - The water heater has not been installed in accordance with the applicable local plumbing and/or building code(s) and/or regulations or in their absence, with the latest edition of the Natural Gas and Propane Installation Code, and/or the Canadian Electrical Code; or
  - The water heater is not installed, operated and maintained in accordance with the Manufacturer's instructions; or

- d. The water heater or any of its component parts are damaged or fails from operation with an empty or partially empty tank (such as, but not limited to elements burned out in a dry tank); or
  - e. The water heater or any part has been under water; or
  - f. The water heater is exposed to highly corrosive atmospheric conditions. No warranty extends, for example, and without limitation of the foregoing, to Units exposed to: salts, chemicals, exhausts, pollutants or contaminants; or
  - g. The water heater is not continuously supplied with potable water; or
  - h. The water heater replacement is requested for reasons of noise, taste, odor, discoloration and/or rust; or
  - i. The water heater is operated at temperatures exceeding the maximum setting of the thermostat and/or high limit control provided by the Manufacturer, or at water pressures exceeding the pressure reading stated on the Unit; or
  - j. The water heater is operated without an operating anode; or
  - k. The water heater is supplied or operated with deionized water; or
  - l. The water heater is removed from its original installation location; or
  - m. The water heater is installed outdoors (this water heater is intended only for indoor installation); or
  - n. The water heater is converted, or is attempted to be converted, from one voltage or wattage to another, if an electric water heater, or from one type gas to another, if a gas water heater; or
  - o. The water heater has not been fired at the factory rated input and fuel for which it was factory built; or
  - p. The water heater or any of its component parts fail due to sediment build-up; or
  - q. The water heater does not have installed a properly operating temperature and pressure relief valve, certified to ANSI Z21.22/CSA "Requirements for Relief Valves for Hot Water Supply Systems"; or
  - r. The water heater or any of its component parts fail because of fire, floods, lightening, or any other act of God, or any other contingency beyond the control of the Manufacturer; or
  - s. The water heater is installed in a closed system without adequate provision for thermal expansion.
3. Except when specifically prohibited by the applicable law, the Owner, and not the Manufacturer, shall be liable for and shall pay for all charges for labour or other expenses incurred in the removal, repair or replacement of the water heater or any component part(s) claimed to be defective or any expense incurred to remedy any defect in the product. Such charges may include, but are not necessarily limited to:
- a. All freight, shipping, handling and delivery costs of forwarding a new water heater or replacement part(s) to the Owner.
  - b. All costs necessary or incidental in removing the defective water heater or component part(s) and installing a new water heater or component part(s).
  - c. Any material required to complete, and/or permits required for, installation of a new water heater or replacement part(s), and
  - d. All costs necessary or incidental in returning the defective water heater or component part(s) to a location designated by the Manufacturer.
4. The terms of this Limited Warranty cannot be modified by any person, whether or not he/she claims to represent or act on behalf of the Manufacturer.
- E. HOW THE ORIGINAL OWNER CAN MAKE A WARRANTY CLAIM.
- 1. The Owner should submit the warranty claim directly to Manufacturer's Service Department, at the address or phone number listed below, and Manufacturer will arrange for the handling of the claim.
  - 2. Whenever any inquiry or request is made, be sure to include the water heater's catalogue number, model number, serial number, date of purchase, date of installation, and location of installation.

This warranty and the Manufacturer's obligations shall be construed and determined in accordance with the laws of both the Province of Ontario, and of Canada in force therein. This Warranty does not affect specific legal rights of a consumer under applicable law, except to the extent that such rights may be waived or replaced, and the provisions hereof are deemed to be amended to the extent necessary. The unenforceability of any provision, in whole or in part, of this Certificate shall not affect the remaining provisions. Any and all repair and/or replacement of part(s) or Unit are the sole and exclusive remedy available against the Manufacturer.

GSW Water Heating  
 599 Hill Street West  
 Fergus, ON Canada N1M 2X1  
 Should you have any questions please  
 Email us at [techsupport@gsw-wh.com](mailto:techsupport@gsw-wh.com) or  
 Visit our websites: [www.gsw-wh.com](http://www.gsw-wh.com) or  
[www.johnwoodwaterheaters.com](http://www.johnwoodwaterheaters.com) or  
 Call our Technical Support line at  
 1-888-GSW-TECH (479-8324)

GSW Water Heating is a division of A.O.Smith Enterprises Ltd.