

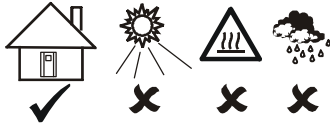

by Schneider Electric

# Installation and Operation Back-UPS™ BE750G Series

## Safety



This UPS is intended for indoor use only.

Do not operate this UPS in direct sunlight, in contact with fluids, or where there is excessive dust or humidity.

Be sure the air vents on the UPS are not blocked. Allow adequate space for proper ventilation.

The battery typically lasts for two to five years. Environmental factors impact battery life. Elevated ambient temperatures, poor quality utility power, and frequent short duration discharges will shorten battery life.

Connect the Back-UPS power cable directly to a wall outlet. Do not use surge protectors or extension cords.

## Specifications

<b>Input</b>	Voltage	120 Vac Nominal
	Frequency	50 Hz/60 Hz auto sensing
	Brownout Transfers	92 Vrms Typical
	Over-voltage Transfer	139 Vrms Typical
<b>Output</b>	UPS Capacity (5 battery backup outlets)	750 VA, 450 W
	Total Amperage (all outlets)	12 A (including UPS output)
	Voltage - On Battery	115 Vrms $\pm$ 8% step approximated sine wave
	Frequency - On Battery	50 Hz/60 Hz $\pm$ 1 Hz
	Transfer Time	6 ms Typical, 10 ms maximum
<b>Protection and Filtering</b>	AC Surge Protection	Full time, 354 Joules
	Phone/DSL/FAX surge protection	Single line (2 wire)
	Cable/CAT V/DSS surge protection	One coax input/output
	Network surge protection	10/100 Base -T ethernet
	EMI/RFI Filter	Full time
	AC Input	Resettable circuit breaker
<b>Battery</b>	Type	Sealed, maintenance-free, lead acid Replacement battery cartridge RBC17
	Average Life	3 - 5 years depending on the number of discharge cycles and environmental temperature
<b>Physical</b>	Net Weight	11 lb (5 kg)
	Dimensions Length x Width x Height	14 in x 7 in x 4 in 36 cm x 18 cm x 9 cm
	Operating Temperature	32° F to 104° F (0° C to 40° C)
	Storage Temperature	5° F to 113° F (-15° C to 45° C)
	Operating Relative Humidity	0 to 95% non-condensing humidity
	Operating Elevation	0 to 10,000 ft (0 to 3000 m)
<b>EMC Compliance</b>	This device complies with part 68 and part 15 of the FCC rules. Operation is subject to the following two conditions: (1) This device may not cause harmful interference, and (2) This device must accept any interference received, including interference that may cause undesired operation.	

# Connect the Battery

The Back-UPS is shipped with one battery cable disconnected. Remove the “*Stop! Connect the Battery*” label that covers the outlets. Prior to connecting any equipment to the unit, connect the battery cable to the unused battery terminal. It is normal for small sparks to be seen when the battery cable is connected to the battery terminal.

- 1 Press the battery compartment cover release tab located on the rear side of the unit. Slide the battery cover off.
- 2 Connect the battery cable securely to the battery terminal.
- 3 Reinstall the battery compartment cover. Be sure that the release tab locks into place.

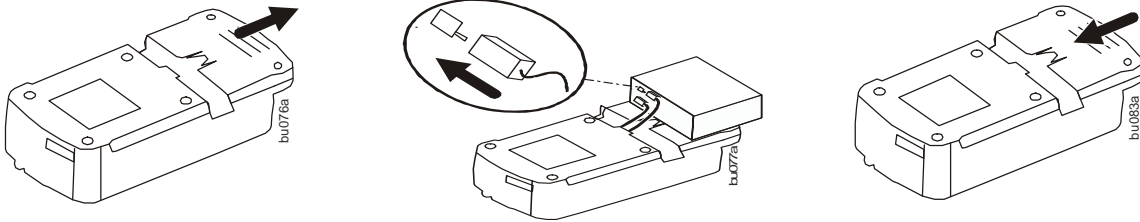

# Wall Mount Installation

- Horizontal installation, use 2 screws 5.9" (150 mm) apart.
- Vertical installation, use 2 screws 5.5" (140 mm) apart.
- Allow 5/16" (8 mm), of the screw to protrude from the wall.

# Connect Equipment

## Battery Backup + Surge Protection Outlets

Battery backup outlets provide protection to connected equipment when the Back-UPS is turned on and connected to utility power.

Battery backup outlets receive power from the Back-UPS for a limited period of time when a power outage, or brownout condition occurs.

Battery backup outlets provide protection from power surges or spikes.

Connect a computer, monitor and other peripheral devices to the outlets.

## Surge Protection Outlets

Surge protection outlets provide protection to connected equipment when the Back-UPS is connected to utility power, and is switched on or off.

Surge protection outlets provide protection from power surges or spikes.

Connect a printer, scanner or other peripheral devices to the surge protection outlets.

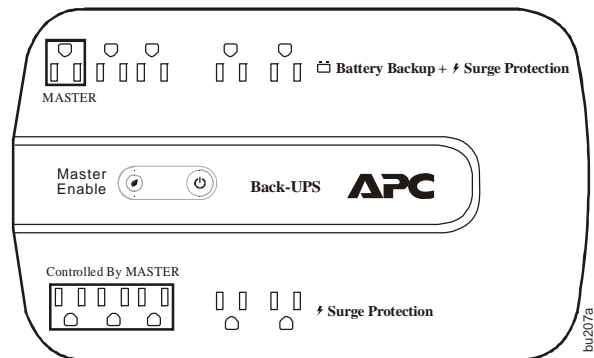

## Connect Modem/Telephone/DSL/FAX/10/100 Base-T Network Cable

The Back-UPS protects a single line, 2 wire telephone line, including a Digital Subscriber Line (DSL), a modem, a 10/100 Base-T ethernet, or a FAX machine from power surges when connected through the Back-UPS coaxial connectors.

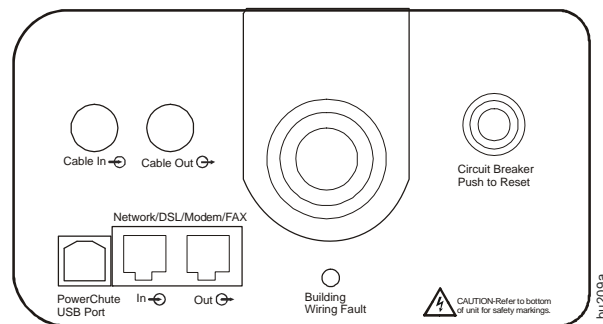

# PowerChute™ Personal Edition Software

## Overview

PowerChute Personal Edition Software allows you to use your computer to access additional power protection and management features of the Back-UPS.

Using PowerChute, you can:

- Preserve work in progress during a power outage by putting your computer into Hibernate mode. When the power returns, the computer will appear exactly as it did before the power outage.
- Configure the Back-UPS management features, such as power-saving outlets, shutdown parameters, audible alarms, and more.
- Monitor and view the status of the Back-UPS, including the estimated runtime, power consumption, power event history, and more.

Available features will vary by Back-UPS model and operating system.

If you choose not to install PowerChute, the Back-UPS will still provide backup power and power protection to connected equipment. However, you will only be able to configure a limited number of features using the display interface.

## Compatibility

PowerChute is compatible with Windows operating systems only. For a detailed list of supported operating systems, go to [www.apc.com](http://www.apc.com), select **Software & Firmware**.

For Mac operating systems, we recommend using the native shutdown application (within System Preferences) which recognizes your battery backup and allows you to configure shutdown of your system during power outages. To access this application, connect a USB cable from the Back-UPS DATA PORT (POWERCHUTE PORT) to a USB port on your computer, and see the documentation provided with your computer.

## Installation

Connect the Back-UPS to a computer using a USB cable. Plug one end into the POWERCHUTE PORT on the rear panel of the Back-UPS and the other into a USB port on your computer.

Insert the PowerChute CD into your computer and follow the on-screen instructions. If your Back-UPS did not come with a PowerChute CD, download the software from [www.apc.com](http://www.apc.com), select **Software & Firmware**.

# Turn On the Back-UPS

Press the **Power ON** button located on the top of the Back-UPS. The **Power On/Replace Battery** LED will illuminate green and a single short beep will be audible to indicate that the Back-UPS is providing protection for connected equipment.

The Back-UPS battery charges fully during the first 16 hours while connected to utility power. The Back-UPS battery will charge while the Back-UPS is switched on or off and is connected to utility power. Do not expect full battery run capability during the initial charge time.

If the red **Building Wiring Fault** LED located on the side of the Back-UPS illuminates, do not operate the Back-UPS. Have a qualified electrician correct the building wiring fault.

## Operation

### Energy Saving Master and Controlled by Master Outlets

When this feature is enabled, a device plugged into the **MASTER** outlet will act as the master on/off switch for devices plugged into the **CONTROLLED BY MASTER** outlets. Turn off or place in Standby mode the device plugged into the **MASTER** outlet and automatically all devices plugged into the **CONTROLLED BY MASTER** outlets will turn off. When the device plugged into the **MASTER** outlet is turned on or is taken out of standby mode, all devices plugged into the **CONTROLLED BY MASTER** outlets will automatically turn on.

Press and hold the **Enable Master** button for one second to enable or disable the feature. The **Enable Master** LED will illuminate green when the feature is enabled. There is no LED illumination when the feature is disabled.

### Program the Threshold Settings

Some computers consume so much power that the **MASTER** outlet does not recognize the reduced power level of standby mode. In this case the **CONTROLLED BY MASTER** outlets will not shut off power to connected devices. When this occurs the threshold setting should be adjusted. Before adjusting the threshold setting verify that the **Enable Master** LED is illuminated green.

If the devices connected to the **CONTROLLED BY MASTER** outlets do not shut down when the **MASTER** device goes into Standby mode, increase the threshold setting to high.

To change the threshold setting:

1. Plug the Back-UPS into a wall outlet. Do Not turn on the Back-UPS. The Back-UPS will be in Standby mode and no LEDs will be illuminated.
2. Press and hold the **ENABLE MASTER** button for 10 seconds, after which all the LEDs will flash. The Back-UPS is now in Threshold Program mode.
3. Release the **ENABLE MASTER** button and the LEDs that remain illuminated indicate the current threshold setting.
4. Press the **ENABLE MASTER** button to change the threshold setting.

Refer to the table below for threshold settings.

<b>Illuminated LED Flashes</b>	<b>Threshold Setting</b>	<b>Input wattage Range in Standby/Sleep Mode</b>
Master Enable LED	Low	10 Watts
Master Enable LED, OnLine LED	Medium (factory default setting)	25 Watts
Master Enable LED, OnLine LED, Replace Battery LED	High	60 Watts

# Status Indicators

Status	LED Indicator	Audible Indicator On	Audible Indicator Terminates
<b>Power On</b> The Back-UPS is supplying utility power to connected equipment.	The green LED illuminates.	None	N/A
<b>On Battery</b> Back-UPS supplying battery power to battery backup outlets.	The green LED illuminates. The LED is not illuminated during the beeps.	Back-UPS beeps 4 times every 30 seconds.	Beeping stops when utility power is restored or the Back-UPS is turned off.
<b>Low Battery warning</b> The Back-UPS is supplying battery power to the battery backup outlets and the battery is near a total discharge state.	The green LED illuminates with rapid green flashes every 1/2 second.	The Back-UPS emits rapid beeping every 1/2 second.	Beeping stops when utility power is restored or the Back-UPS is turned off.
<b>Replace Battery</b> <ul style="list-style-type: none"> <li>• The battery is disconnected.</li> <li>• The battery needs to be charged, or replaced.</li> </ul>	<ul style="list-style-type: none"> <li>• <b>Power On/Replace Battery</b> LEDs flash alternately green/red.</li> <li>• <b>Replace Battery LED</b> flashes red.</li> </ul>	Constant tone  Constant tone	Back-UPS is turned off.
<b>Overload Shutdown</b> While on battery power an overload condition has occurred in one or more of the battery backup outlets while the Back-UPS is operating on battery power.	None	Constant tone	Back-UPS is turned off.
<b>Overload Alarm</b> While on utility power the online power exceeds the Back-UPS capacity.	<b>Power On LED</b> illuminates green.	Constant tone	Beeping stops when equipment power plugs are moved from battery backup outlets to surge protection outlets.
<b>Sleep Mode</b> While on battery power the battery is completely discharged. The Back-UPS will “awaken” once utility power is restored.	None	The Back-UPS beeps once every four seconds.	Beeping stops when: <ul style="list-style-type: none"> <li>• Utility power is restored</li> <li>• If utility power is not restored within 32 seconds</li> <li>• The Back-UPS is turned off</li> </ul>
<b>Building Wiring Fault</b> The building wiring presents a shock hazard that must be corrected by a qualified electrical.	<b>Building Wiring Fault LED</b> illuminates red	None	The Back-UPS is unplugged from the wall outlet or is plugged into an improperly wired outlet.

# Voltage Sensitivity Adjustment

The Back-UPS detects and reacts to line voltage distortions by transferring to battery backup power to protect connected equipment. In situations where either the Back-UPS or the connected equipment is too sensitive for the input voltage level it is necessary to adjust the transfer voltage setting.

1. Connect the Back-UPS to a wall outlet. The Back-UPS will be in **Standby** mode, no indicators will be illuminated.
2. Press and hold the ON/OFF button for 10 seconds. The ON/OFF button will illuminate alternately green-red, to indicate that the Back-UPS is in **Program** mode.
3. The **Power On/Replace Battery** LED will flash either green, or red to indicate the current sensitivity level. Refer to the table for an explanation of the transfer voltage sensitivity levels.
4. To select LOW sensitivity, press and hold the ON/OFF button until the LED flashes green.
5. To select MEDIUM sensitivity (factory default), press and hold the ON/OFF button until the LED flashes red.
6. To select HIGH sensitivity, press and hold the ON/OFF button until the LED flashes green and red simultaneously.
7. To exit **Program** mode wait five seconds and all LED indicators will extinguish. **Program** mode is no longer active.

LED Flashes	Sensitivity Setting	Input Voltage Range for Utility Operation	Recommended Use
Green	LOW	88 Vac to 142 Vac	Use this setting with equipment that is less sensitive to fluctuations in voltage or waveform distortions.
Red	MEDIUM (factory default)	92 Vac to 139 Vac	Use this setting under normal conditions.
Green and red simultaneously	HIGH	96 Vac to 136 Vac	Use this setting when connected equipment is sensitive to voltage and waveform fluctuations.

# Troubleshooting

Problem and Possible Cause	Solution
<b>The Back-UPS will not turn on</b>	
The Back-UPS has not been turned on.	Press the POWER ON button.
The Back-UPS is not connected to utility power, there is no utility power available at the wall outlet, or the utility power is experiencing a brownout or over voltage condition.	Make sure the power cord is securely connected to the wall outlet, and that there is utility power available at the wall outlet. Where applicable, check that the wall outlet is switched on.
The battery is not connected.	Connect the battery. Refer to “Connect the Battery” on page 2 of this manual. In the event the Back-UPS receives no utility power and the battery is connected, a cold-start can be initiated. Press and hold the <b>Power On</b> button until the Back-UPS emits two beeps.
<b>The Back-UPS is on, the Power On/Replace Battery LED flashes and the unit emits a constant tone</b>	
The battery is disconnected.	Refer to the “Connect the Battery” on page 2 in this guide.
<b>Connected equipment loses power</b>	
A Back-UPS overload condition has occurred.	Remove all nonessential equipment connected to the outlets. One at a time reconnect equipment to the Back-UPS.
The Back-UPS battery is completely discharged.	Connect the Back-UPS to utility power and allow the battery to recharge for eight hours.
PowerChute software has performed a shutdown due to a power failure.	This is normal Back-UPS operation.
Connected equipment does not accept the step-approximated sine waveform from the Back-UPS.	The output waveform is intended for computers and peripheral devices. It is not intended for use with motor driven equipment.
The Back-UPS may require service.	Contact APC Technical Support for more in depth troubleshooting.
<b>The Power On LED is illuminated and the Back-UPS beeps 4 times every 30 seconds</b>	
The Back-UPS is operating on battery power.	The Back-UPS is operating normally on battery power. At this point the user should save all open files, and shutdown the computer. When utility power is restored the battery will recharge.
<b>The Power On LED flashes once every second while the Back-UPS beeps once every second</b>	
The Back-UPS battery has approximately two minutes of remaining runtime.	The Back-UPS battery is near a total discharge state. At this point the user should save all open files, and shutdown the computer. When utility power is restored the battery will recharge.
<b>The Back-UPS has an inadequate battery runtime</b>	
The battery is not fully charged.	Leave the Back-UPS connected to utility power for 16 hours while the battery charges to full capacity.
The battery is near the end of useful life and should be replaced.	As a battery ages, the runtime capability decreases. Contact APC at the Web site <a href="http://www.apc.com">www.apc.com</a> , to order replacement batteries.
<b>The Building Wiring Fault LED illuminates</b>	
The building wiring presents a shock hazard that must be corrected by a qualified electrical.	Do not operate the Back-UPS. Call a qualified electrician to correct the building wiring fault.
<b>The connection from the Back-UPS to the Network/DSL/Modem/FAX is lost</b>	
There is no network/DSL/FAX/ modem signal from the Back-UPS.	Verify that the data line from the wall outlet is connected to appropriate port on the Back-UPS.
The internet connection is lost during a power outage.	Connect the utility power cord from the modem into one of the Battery Backup+Surge Protection outlets on the Back-UPS.

# Replace Battery

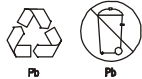

Use only approved APC replacement battery cartridge.

Deliver used batteries to a battery replacement facility in the packaging provided by APC with the replacement battery cartridge.

To order replacement battery cartridges contact APC through the Web site [www.apc.com](http://www.apc.com).

## Warranty

The standard warranty is 3 years in the USA and Canada, 2 years in all other regions from the date of purchase. APC standard procedure is to replace the original unit with a factory reconditioned unit. Customers who must have the original unit back due to assigned asset tags and set depreciation schedules must declare such a need at first contact with APC Technical Support. APC will ship the replacement unit once the defective unit is received by the repair department or cross-ship upon the provision of a valid credit card number. The customer pays for shipping to APC, and APC pays ground freight transportation costs back to the customer.

## Service

If the unit requires service, do not return it to the dealer. Follow these steps:

1. Review the *Troubleshooting* section of the manual to eliminate common problems.
2. If the problem persists, contact APC Customer Support through the Web site, [www.apc.com](http://www.apc.com).
  - a. Note the model number and serial number and the date of purchase. The model and serial numbers are located on the rear panel of the unit and are available through the LCD display on select models.
  - b. Call APC Customer Support and a technician will attempt to solve the problem over the phone. If this is not possible, the technician will issue a Returned Material Authorization Number (RMA#).
  - c. If the unit is under warranty, the repairs are free.
  - d. Service procedures and returns may vary internationally. Refer to the APC Web site for country specific instructions.
3. Pack the unit properly to avoid damage in transit. Never use foam beads for packaging. Damage sustained in transit is not covered under warranty.

**Note: When shipping within the United States, or to the United States always DISCONNECT A UPS BATTERY before shipping in compliance with U.S. Department of Transportation (DOT) and IATA regulations. The internal batteries may remain in the UPS.**
4. Write the RMA# provided by Customer Support on the outside of the package.
5. Return the unit by insured, pre-paid carrier to the address provided by Customer Support.

### APC Customer Support Worldwide

**Internet** <http://www.apc.com>

**Telephone** 888 272 3858