

# *the Fast Slow Cooker™*

Instruction Book - BPR650



**Breville®**



## Contents

2	Breville Recommends Safety First
10	Components
16	Quick Start Guide
18	Functions
37	Care & Cleaning
40	Troubleshooting

## BREVILLE RECOMMENDS SAFETY FIRST

At Breville we are very safety conscious. We design and manufacture consumer products with the safety of you, our valued customer, foremost in mind. In addition we ask that you exercise a degree of care when using any electrical appliance and adhere to the following precautions.

## IMPORTANT SAFEGUARDS

### READ ALL INSTRUCTIONS BEFORE USE AND SAVE FOR FUTURE REFERENCE

- Remove and safely discard any packaging material and promotional labels before using the Breville Fast Slow Cooker for the first time.
- To eliminate a choking hazard for young children, remove and safely discard the protective cover fitted to the power plug of this appliance.
- Do not immerse appliance base, power cord or plug in water or any other liquid.

- Always insert the connector end of the power cord into appliance inlet inserting power plug into power outlet and switching on appliance. Ensure the appliance inlet is completely dry before inserting the connector end of the power cord.
- This appliance cooks under pressure. Improper use may result in injury. When using this appliance for any function other than sauté, ensure the lid is properly assembled and locked into position before use.
- Do not place Breville Fast Slow Cooker near the edge of a bench or table during operation. Ensure that the surface is level, clean and free of water and other substances.
- Do not operate Breville Fast Slow Cooker on a sink drain board.
- We recommend the slow cooker is not placed on a stone bench top when it's cooking. This is due to bench tops being sensitive to uneven heat and may crack if heated locally. If you would like to cook with the slow cooker on the bench top, place a chopping board or heat proof mat underneath the slow cooker.
- Never move the Pressure Cooker when in use or whilst the cooker is still under pressure. Movement may result in inadvertent movement of the pressure release valve/ release valve resulting in unexpected steam or hot liquid being released from the pressure release valve or the side of the lid which may cause scalding.

- Do not place this appliance on or near a hot gas burner, electric element or where it could touch a heated oven. Position Breville Fast Slow Cooker at a minimum distance of 20cm away from walls and provide adequate space above and all sides for air circulation.
- Keep the Breville Fast Slow Cooker clear of walls, curtains and other heat or steam sensitive materials.
- Do not touch hot surfaces. Use handles on the sides of appliance and on lid. Use the button to release steam pressure.
- Always ensure Breville Fast Slow Cooker is properly assembled before use. Follow the instructions provided in this book.
- Before placing removable cooking bowl into stainless steel base ensure base of bowl and base of appliance is dry by wiping with a dry soft cloth.
- Do not place food or liquid directly into stainless steel base. Only removable cooking bowl is designed to contain food or liquid.
- Always follow the maximum and minimum quantities of liquid stated in instructions and recipes.

- Do not exceed maximum fill level. Some foods expand during pressure cooking such as rice, diced vegetables, do not fill removable cooking pan over ½ full. Over filling may cause a risk of clogging pressure release valve and safety locking pin valve and develop excess pressure.
- Do not use a damaged removable cooking bowl. Replace before using.
- Ensure that lid is properly closed before operating (see step 4 page 22).
- Do not use Breville Fast Slow Cooker for other than it's intended use. Do not attempt to operate Breville Fast Slow Cooker by any method other than those described in this book.
- Removable cooking bowl can be extremely heavy when full of ingredients, care should be taken when lifting from Breville Fast Slow Cooker base.
- Always check pressure release valve and safety locking pin valve for clogging before use and clean if necessary. Check to make sure the safety locking pin moves freely from under the lid.
- Extreme caution must be used when appliance contains hot food and liquids and/or is under pressure. Improper use may result in injury. When using this appliance for any function except sauté, make sure the lid is properly locked before operating.

- Do not use the lid handle to carry appliance when in use and after use.
- Do not attempt to open Breville Fast Slow Cooker lid after pressure cooking until all internal pressure has been released and is slightly cooled. If the lid will not turn to unlock, this indicates that appliance is still under pressure – do not force lid open. Any pressure remaining can be hazardous. See operating instructions for STEAM RELEASE directions in this instruction book (see step 10-12 page 24).
- Always ensure that removable cooking bowl has cooled sufficiently before handling and use oven mitts as a precaution.
- Do not touch hot surfaces. The heating element/plate surface is subject to residual heat after use.
- The Breville Fast Slow Cooker is not intended to be operated by means of an external timer or separate remote control system.
- Do not place anything, other than lid, on top of Breville Fast Slow Cooker when assembled, when in use and when stored.
- Do not adjust the pressure release valve while cooking.
- Use only recommended STEAM RELEASE to depressurize cooker after use (see step 10-12 page 24).

- Do not use this cooker for deep frying.
- Do not sauté or shallow fry under pressure.
- Always ensure there is enough liquid in removable cooking bowl when steaming. At least 4 cups (1 litre) of liquid is required when steaming.
- Always ensure START/CANCEL has been pressed to CANCEL, then turn the power off at the power outlet and remove power plug from the power outlet before attempting to move the appliance, when appliance is not in use and before cleaning and storing.
- To protect against electric shock, do not immerse Breville Fast Slow Cooker base, power base, power cord or power plug in water or allow moisture to come in contact with these parts.
- Keep Breville Fast Slow Cooker clean. Follow the cleaning instructions provided in this book (see page 37).

# IMPORTANT SAFEGUARDS FOR ALL ELECTRICAL APPLIANCES

- Fully unwind the power cord before use.
- Do not let the power cord hang over the edge of a bench or table, touch hot surfaces or become knotted.
- To protect against electric shock do not immerse the power cord, power plug or appliance in water or any other liquid.
- The appliance is not intended for use by persons (including children) with reduced physical, sensory or mental capabilities, or lack of experience and knowledge, unless they have been given supervision or instruction concerning use of the appliance by a person responsible for their safety.
- Children should be supervised to ensure that they do not play with the appliance.



- It is recommended to regularly inspect the appliance. To avoid a hazard do not use the appliance if power cord, power plug or appliance becomes damaged in any way. Return the entire appliance to the nearest authorised Breville Service Centre for examination and/or repair.
- Any maintenance other than cleaning should be performed at an authorised Breville Service Centre.
- This appliance is for household use only. Do not use this appliance for anything other than its intended use. Do not use in moving vehicles or boats. Do not use outdoors. Misuse may cause injury.
- The installation of a residual current device (safety switch) is recommended to provide additional safety protection when using electrical appliances. It is advisable that a safety switch with a rated residual operating current not exceeding 30mA be installed in the electrical circuit supplying the appliance. See your electrician for professional advice.

**FOR HOUSEHOLD USE ONLY  
SAVE THESE INSTRUCTIONS**



## Components

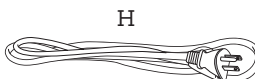
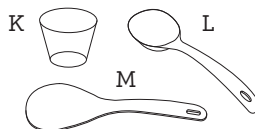
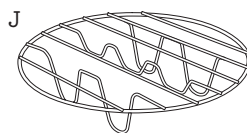
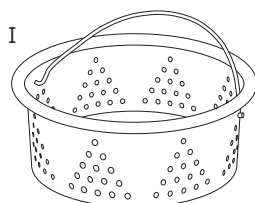
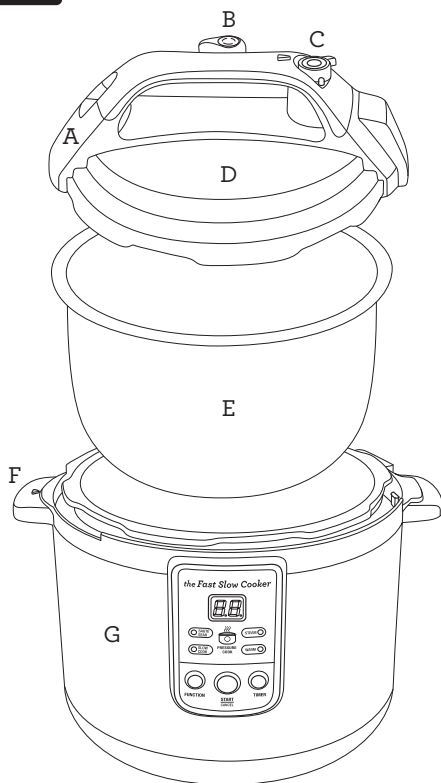

- A. Lid handle
- B. Pressure release valve  
Controls rate at which steam vents out of cooker and subsequently degree of pressure inside the cover.
- C. Adjustable pressure control dial  
Choose from Low, Medium or High.
- D. Safety locking lid  
Can not be opened whilst pressure cooking.  
Not dishwasher safe.
- E. 6 Litre removable non-stick cooking bowl  
Dishwasher safe.
- F. Cool touch handles
- G. Brushed stainless steel base & lid

- H. Removable power cord  
For serving at table & easy storage.

### Accessories

- I. Stainless steel steaming basket  
Dishwasher safe.
- J. Stainless steel trivet  
Raises food out of liquid for roasting, steaming and pressure cook or slow cook settings.
- K. Rice duo measuring cup
- L. Serving spoon
- M. Heat resistant spatula  
To avoid scratching non stick surface of cooking bowl.

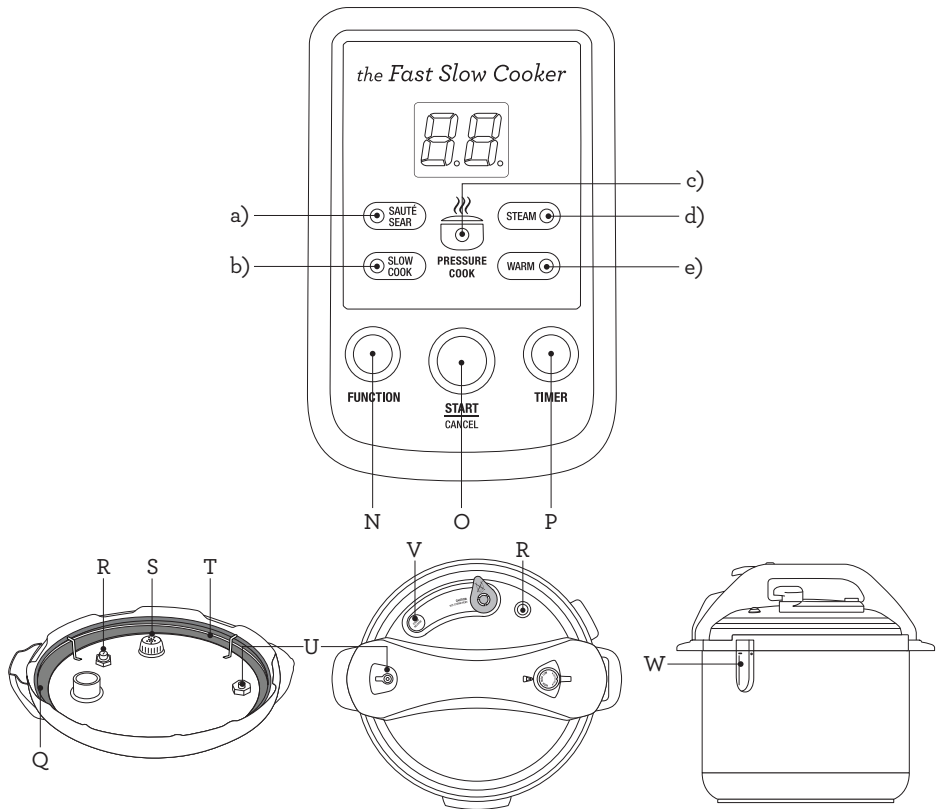

## Control Panel

### N. Function button

Press to select desired cooking method.

### Setting selection

#### a) SAUTE/SEAR Indicator Light

Sear and brown meats plus saute onions and garlic, before pressure cooking or slow cooking.

#### b) SLOW COOK Indicator Light

Select from 6 hours or 8 hours.

#### c) PRESSURE COOK Indicator Light

#### d) STEAM Indicator Light

#### e) WARM Indicator Light

Automatic or manual.

### O. Start/cancel button

### P. Timer button

Sets cooking time.

### Q. Silicone rubber sealing gasket

Dishwasher safe.

### R. Pressure safety valve

### S. Pressure release valve cover

### T. Gasket holder

### U. Safety locking pin

Pin pops up once pressure is reached acting as a safety device.

### V. Steam release button

Press the button in short bursts until safety locking pin drops down, then the lid can be opened.

### W. Steam condensation collector

Dishwasher safe.



## Important Safety Information For Your Fast Slow Cooker™

### **NEVER FORCE THE COOKER LID CLOSED**

- The lid should be effortless to close. It should only require the use of one hand in a smooth action. If you encounter resistance, do not force the lid into position.
- The lid is correctly locked when the locking arrows are aligned and the safety locking pin is in the down position.
- Forcing the lid onto the cooker can cause air to become trapped and the locking pin to rise prematurely making it difficult to close.

- If the lid is difficult to close, check and ensure the seal is correctly installed. Turn the pressure release valve so that it is not in the “Pressure” position. This will assist with reducing the resistance when closing the cooker lid.

### **RELEASING PRESSURE**

- Never place your hands, arms or face over the pressure release valve when the cooker is in use.
- Pressure can be released by pressing and holding the steam release button on the lid. This should be initially done in short bursts to prevent large jets of steam being released.

Using a wooden spoon to turn the pressure release valve into the open position will assist with a fast steam release, take care as the jet of steam may be hazardous.

- Soups, stocks and recipes with a lot of liquid can force liquid through the pressure release valve during pressure release. Release pressure in intervals by pressing and releasing the steam release button or switch off the cooker and let it depressurise naturally.

## Quick Release

This method uses the Steam Release Button when there is no more steam coming out, turn the pressure release valve to "steam release position".

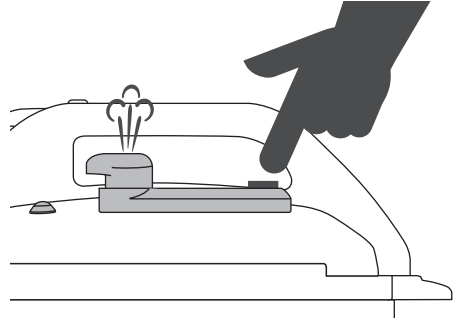

Wait a minimum 1 minute after releasing pressure/steam to unlock and remove the lid. To open the lid, use handle in a counterclockwise direction while aligning ALIGN arrows to the OPEN position. This should be effortless.

## Side view

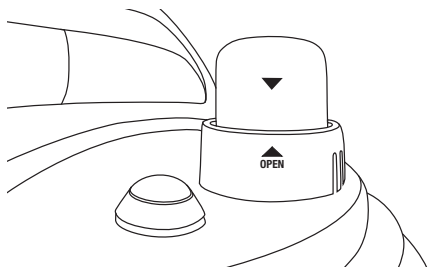

## Top view

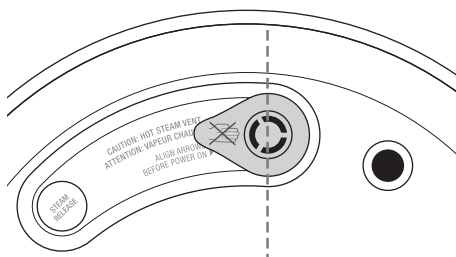

## IMPORTANT

Steam Release Button will be hot if pressed for prolonged period.

## Slow Release

If the Steam release button is not depressed when cooking is finished, the cooker will slowly de-pressurize when the temperature drops towards room temperature. This method is recommended for recipes containing larger quantities of liquid such as soups and casseroles to prevent liquid being forced out with the steam. The Slow release method is also used to finish off recipes such as risottos and puddings.

When slow release method is used, it is necessary to push the steam release button to ensure there is no more steam coming out and turn the pressure release valve to the "steam release position" where arrows are aligned to OPEN arrow before attempting to open the lid.

The pressure release valve can get extremely hot after cooking. Extreme caution must be used when moving the pressure release valve. It is recommended to use a tool as an aid to move the pressure release valve.

## **NEVER FORCE THE LID OPEN**

- After all internal pressure is released, the lid should be effortless to open. It should only require the use of one hand in a smooth action.
- If the lid will not unlock or you encounter resistance, it may indicate the appliance is still under pressure. Never force the lid open as any remaining pressure can be hazardous.
- Press the steam release button until all internal pressure is released and the cooker can be opened.
- If there is no more steam coming from the valve, the safety locking pin may still be in the locked position. Gently tap on the handle to unlock the pin and open the lid.
- If resistance is still encountered, disconnect from the power supply and allow the pressure cooker to cool down to room temperature. Never force the lid open.

# Quick Start Guide

This Quick Start Guide is designed for first time use.

For safety and more information, refer to your Instruction Booklet.

## A

### Before First Use

Preparing the Fast Slow Cooker for use

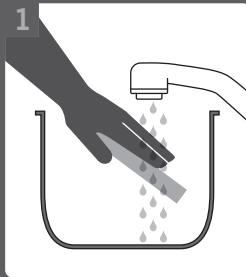

1 Remove Lid. Wash non-stick cooking bowl.



2 Wash silicone rubber gasket.

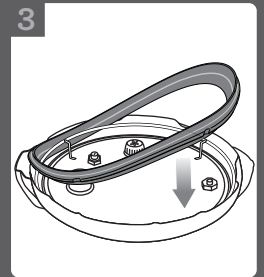

3 Return dry clean silicone rubber gasket securely back to gasket.

## B

### How to Pressure Cook

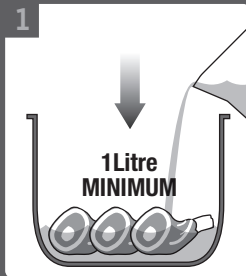

1 Place food to be cooked into removable cooking bowl with 1L minimum liquid.

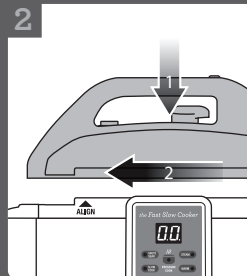

2 Close and lock lid in a clockwise direction by aligning arrows.

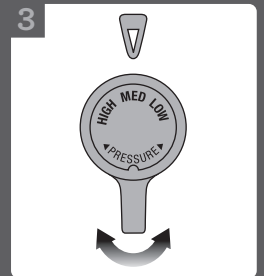

3 Select Pressure setting using Pressure Control Dial on lid handle (Low, Medium, High).

### 4

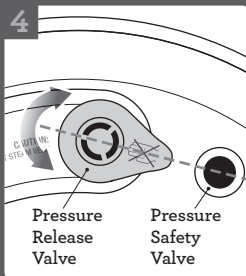

Ensure Pressure Release Valve is turned to Pressure position.

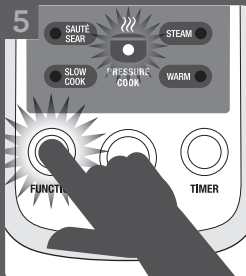

5 Press FUNCTION button until the Pressure Cook indicator light flashes.

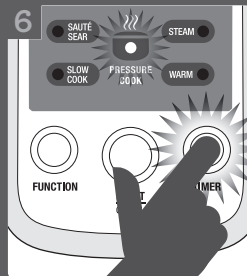

6 Press TIMER Button – select from 02 to 99 minutes.

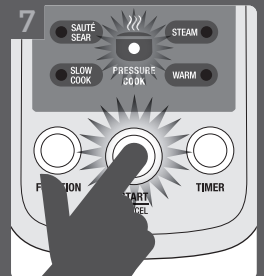

7 Press START/CANCEL button to start Pressure Cooking – indicator light will stop flashing.



# C

## How to Sear

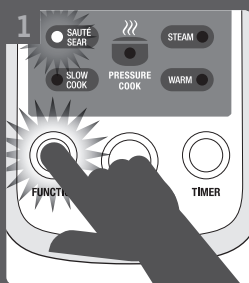

Press FUNCTION button until SAUTÉ/SEAR function indicator light flashes.

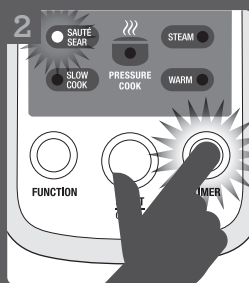

Press TIMER Button – select from 02 to 99 minutes.

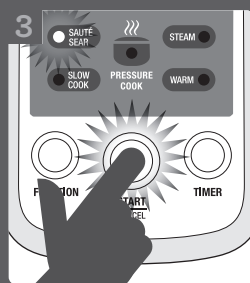

Press START/CANCEL button to start cooking – indicator light will stop flashing.

# D

## How to Slow Cook

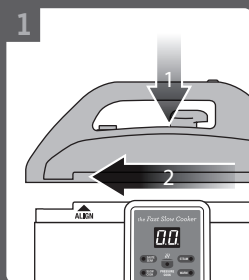

Close and lock lid in a clockwise direction by aligning arrows.

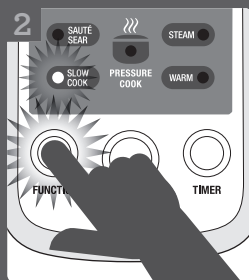

Press FUNCTION button until SLOW COOK indicator light flashes.

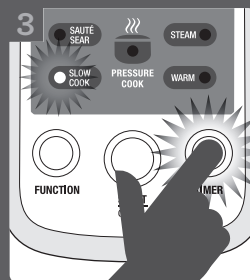

Press TIMER button and select either 6 or 8 hours.

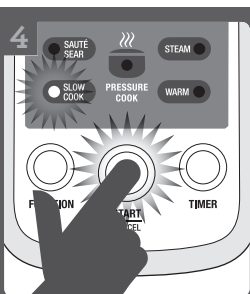

Press START/CANCEL button to start SLOW COOKING – indicator light will stop flashing.

# E

## How to Steam

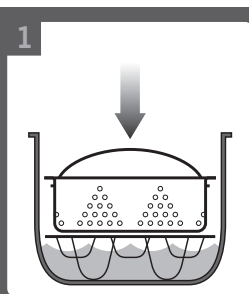

Place steaming basket on to trivet and position inside cooking bowl.

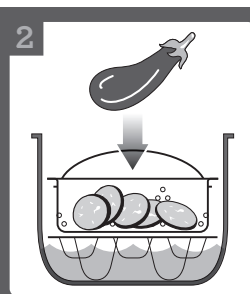

Repeat steps (1) to (3) in How To Pressure Cook. Place food into steaming basket.



Select FUNCTION button until STEAM function indicator light flashes.

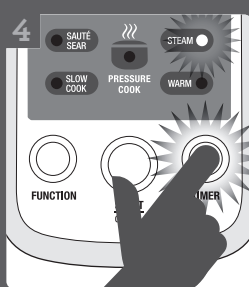

Press TIMER Button – select from 02 to 99 minutes.

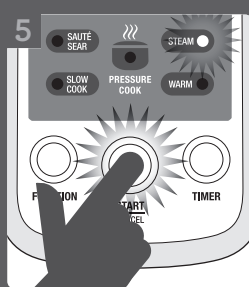

Press START/CANCEL button to start STEAMING – indicator light will stop flashing.

**Australia**  
1300 139 798

**New Zealand**  
0800 273 845

Refer to the Instruction Book or Contact Customer Service.



## Functions

### PREPARING THE FAST SLOW COOKER FOR USE

1. Before first use, remove all promotional labels and packing materials and discard in a safe place to avoid a choking hazard.
2. Remove the lid by taking hold of the handle, turning it counter clockwise and lifting the lid up and off the appliance.

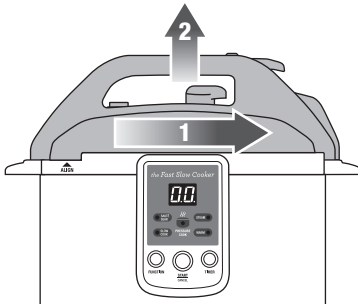

3. Wash the removable cooking bowl, stainless steel lid and silicone rubber gasket in hot, soapy water, rinse and dry thoroughly. Wipe the inside and the outside of the stainless steel base with a soft, damp cloth, then dry thoroughly.
4. Attach the clean silicone rubber gasket securely back into the gasket holder as illustrated. Ensure that the gasket is installed correctly and the wire ring is fully sitting inside the groove of the silicone seal.

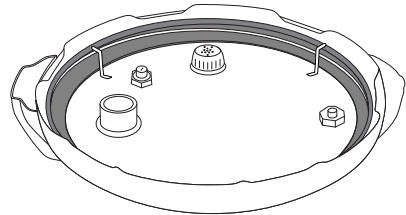
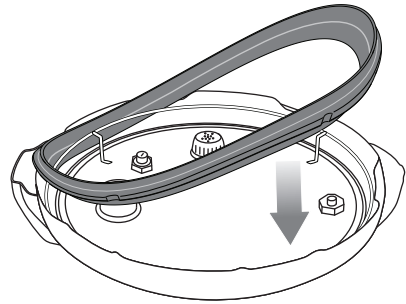

### IMPORTANT

If the silicone rubber gasket is not fitted correctly into the holder, the lid will not seal properly. This may cause the appliance to malfunction and leak steam or hot liquid which can cause burn or scalding.

5. Clean and dry the bottom of the removable cooking bowl as well as the temperature sensor, making sure there are no unwanted materials on the surface. The removable cooking bowl must sit flat on the temperature sensor to ensure proper contact.

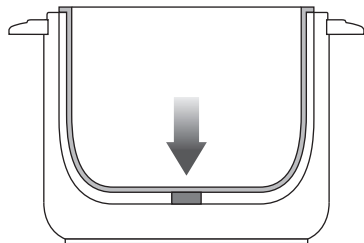



## DO'S

- ✓ Always thaw frozen meat and poultry before cooking.
- ✓ Use dry oven mitts when lifting the removable bowl after cooking.
- ✓ Always store Breville Fast Slow Cooker in a cool, dry place.



## DONT'S

- ✗ Do not operate any of settings without removable cooking bowl in position.
- ✗ Do not cook with frozen meats or poultry.
- ✗ Do not remove stainless steel lid when using the Slow Cook setting unnecessarily as this will result in major heat loss.



## NEVER

- ✗ Place water or other liquids into the stainless steel base of Breville Fast Slow Cooker.
- ✗ Immerse base, cord, or plug of Breville Fast Slow Cooker in water or any other liquid.
- ✗ Touch hot surfaces with bare hands.
- ✗ Deep fry in Breville Fast Slow Cooker.
- ✗ To prevent aromas, moulds and odours, never store YOUR BREVILLE PRODUCT closed with lid locked in place. Follow the care and cleaning guidelines on page 37. Pack and store with lid resting upside down on removable cooking bowl in a well ventilated area.

## PREPARING MEAT AND POULTRY

Select cuts of meat suitable for pressure cooking by choosing cuts from the table below. Pressure cooking allows less tender cuts of meat to be cooked quickly and achieve a tender juicy result.

Using meat cuts with bones produces a more flavoursome and enriched result.

For best results, always trim away excess visible fat, grizzle and skin. These will form extra liquid as it melts and cooks.

For casserole type recipes, cut meat into even cubes approximately 3-5cm.

### Suitable meat cuts for pressure cooking and slow cooking

MEAT	CUTS
<b>Beef &amp; Veal</b>	Chuck, skirt, round steak, boneless shin(Gravy) beef, bone-in shin and cheeks(Osso Bucco), Diced leg, shoulder/ forequarter chops and steaks, neck chops, knuckle (Osso Bucco).
<b>Lamb</b>	Shanks, drumsticks (frenched shanks), neck chops, boned out forequarter or shoulder.
<b>Pork</b>	Diced leg, shoulder/ forequarter chops and steaks, neck chops, knuckle (Osso Bucco).
<b>Chicken</b>	Chicken drumsticks and thighs both bone in and fillet.

## PREPARING VEGETABLES

Vegetables should be cut into even-sized pieces to ensure more even cooking.

When preparing vegetables for pressure cooking, always use fresh and not frozen.

If only frozen vegetables are available, thaw out before pressure cooking. Use LOW pressure setting for minimum time.

For better results only peel vegetables when appropriate. Hard vegetables such as beetroot and potatoes hold their shape better when left intact.

## PREPARING DRIED PULSES (BEANS AND PEAS)

Legumes and pulses can be cooked without prior soaking.

To fasten the pressure cooking time, soak dried pulses in boiling water for 3 hours or overnight.

Always wash and drain pulses before cooking. Remove any discoloured pulses.

For best cooking results, place pulses into Breville Fast Slow Cooker and cover with water or stock at least 5cm above the level of pulses.

Onions, bay leaves and garlic can be added to flavour the pulses.

Avoid adding salt prior to cooking, as this will toughen the skins of the beans and peas and prevent proper cooking.

Once pulses have cooked, drain away excess liquid, rinse lightly and use in recipes.

Softer Pulses such as mung beans, lima beans and butter beans are best to be cooked using LOW or MEDIUM pressure.



### IMPORTANT

- Softer Pulses such as; mung beans, lima beans and butter beans are best cooked using LOW AND MEDIUM pressure.
- When PRESSURE COOKING AND SLOW COOKING the resulting juices and liquids created by cooking may need to be evaporated and concentrated. We suggest that the SAUTE/SEAR function should be used for approx 5-10 minutes depending on amount of liquids required to be reduced.

## SAUTÉING AND SEARING BEFORE PRESSURE COOKING & SLOW COOKING

Sautéing and Searing in Breville Fast Slow Cooker may take a little extra time and whilst not strictly necessary, the rewards are evident in the end result.

Saute and Sear setting keeps the heat stable, browning meat and caramelising vegetables. This seals in the moisture, tenderises and intensifies the flavour.

### Hint and Tips

- Trim excess fat from meat or poultry.
- If a recipe calls for browning meat, it may be browned using SAUTÉ/SEAR setting.
- If after cooking the liquid quantity is excessive, remove the lid and operate Breville Fast Slow Cooker on SAUTÉ/SEAR setting for approximately 10-15 minutes or until the liquid reduces by the desired amount.

### How to Sauté and Sear

1. Remove power cord, connect it to pressure cooker base and insert power cord to 230/240 volt power outlet. A single beep will sound and 0:0 will be displayed on LED display.



- Click steam condensation collector into place.

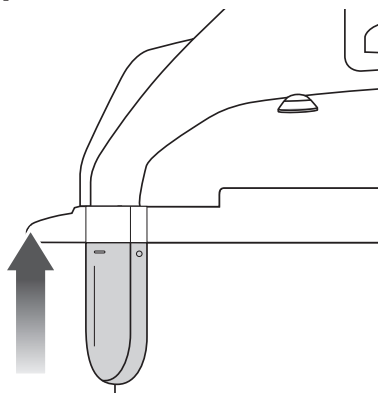

- Always ensure the lid is removed from pressure cooker before sautéing or searing.
- Press Function Button until SAUTÉ/SEAR indicator light flashes red.
- Press TIMER button to increase time from 02 minutes to maximum 99 minutes. To fast advance time, press and hold TIMER button until desired time is displayed.
- When desired cooking time is displayed, press START/CANCEL button. SAUTÉ/SEAR indicator light will stop flashing and will illuminate a solid red. The count down timer will commence. Allow Breville Fast Slow Cooker to heat with the lid off for approximately 2-3 minutes before cooking.
- Add a small amount of oil or butter to removable cooking bowl.
- Place food to be sautéed/seared into cooking bowl. Depending on quantity of food, meat searing should be done in small batches.

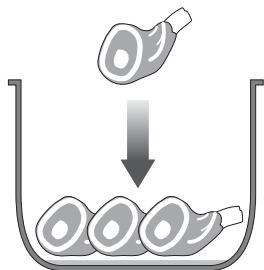

- When finished sautéing or searing, select PRESSURE COOK or SLOW COOK by pressing FUNCTION button. (Refer to pressure cook or slow cook HOW TO section on page 22-28 and page 31-33).

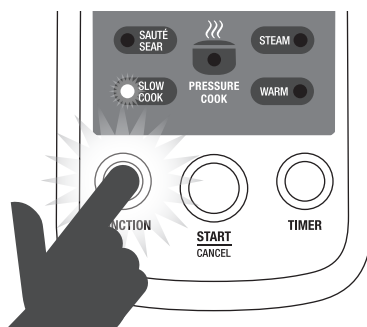

### IMPORTANT

- SAUTÉ/SEAR function will not work if lid is sealed and locked in position. An audible alarm will sound. E3 error code will appear on LED display to signal the need to unlock or remove the lid.
- Stir food in removable cooking bowl, using heat resistant spatula supplied.
- Do not use metal utensils because they will scratch non stick coating on the removable cooking bowl.
- Do not heat removable cooking bowl when empty for more than 10 minutes as it may damage the cooking surface.
- Caution should be used when searing meats and sautéing in hot oil. Keep hands and face away from the removable cooking bowl especially when adding new ingredients as hot oil may splatter.

## A BEGINNER'S GUIDE TO PRESSURE COOKING

Pressure cookers are back in the forefront again. These time savers are wonderful for cooking succulent roasts, flavoursome casseroles, delicious soups and even desserts in a fraction of the time and energy they take by conventional methods.

Pressure Cooking is a method of cooking food in a small amount of liquid with a gasket sealed lid that retains steam inside and builds pressure. It is the increase in pressure that raises temperature of the liquid and steam inside to well above boiling point and therefore allows food to be cooked up to 70% faster.

This means less energy is consumed and you will enjoy substantial savings in both time and cost. Because pressure cooked foods require very little cooking liquid, more vitamins, minerals, and other nutrients are retained and the natural flavours are enhanced.

### How to Pressure Cook

1. Place removable cooking bowl into stainless steel base.

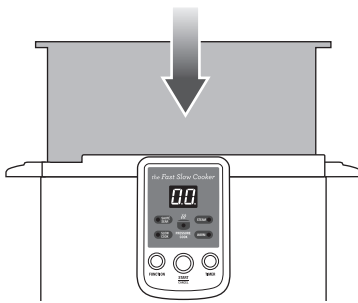

2. Attach clean silicone rubber gasket securely into gasket holder.



### NOTE

Fit silicone rubber sealing gasket into lid if not already in place. If the silicone rubber gasket is not installed correctly into the holder, the lid will not seal properly. This may cause the appliance to malfunction and leak steam or hot liquid which can cause burns or scalding.

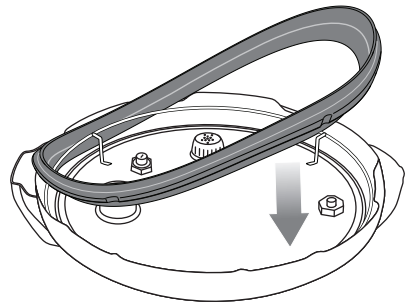

3. Always have a minimum of 1 litre (4 cups) of combined food and liquid in removable cooking bowl.



- Close and lock lid by using the handle. Close lid in a clockwise direction by aligning ALIGN arrows. The Lid arrow should align with stainless steel base arrow until it locks into place and is in the CLOSE position.

**NOTE**

This should be effortless!

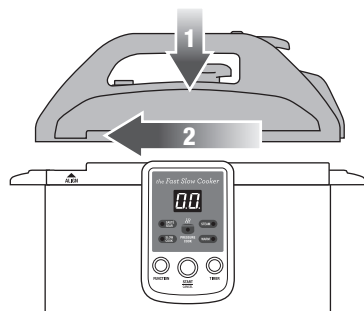

- Select one of the following settings using the Pressure Control dial located on the handle:
  - Low (Low Pressure).
  - Medium (Moderate Pressure).
  - High (High Pressure).

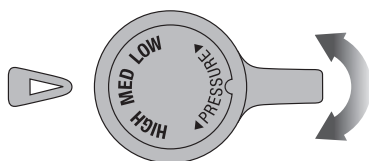

**NOTE**

Refer to Pressure Cooking guide and basic recipes on page 22-31.

- Ensure pressure release valve is turned to PRESSURE position. For correct PRESSURE position, align the pressure release valve with the dash graphic that goes across the pressure safety valve. See diagram below.

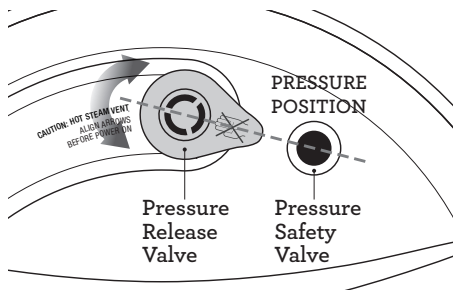

The illustration above shows the correct Pressure Release Valve position.

**NOTE**

The arrowheads should be aligned.

You may need to adjust the Pressure Release Valve until it is in the correct position.

- Press FUNCTION button until PRESSURE COOK indicator light flashes red.
- To set TIMER; press TIMER button to increase cooking time. This will be illuminated on LED display from 02 minutes to maximum 99 minutes. To fast advance time, press and hold down TIMER button. When desired cooking time is displayed, press START/CANCEL button.

The function indicator light will stop flashing and will illuminate a solid red. Preheating will begin, control panel will continue to display selected cooking time. As selected pressure setting is achieved, there will be a slight hissing of steam from pressure release valve. After approximately 10 minutes, or more depending on the amount of liquid added to cooking bowl, selected cooking time will begin to count down in minutes and this is shown on LED display.

9. When LED displays 0 cooking has finished. Breville Fast Slow Cooker will sound 5 beeps.



10. To release pressure from pressure release valve, press pressure release button until initial bursts of steam have been released. Then you may either continue to press the pressure release button or rotate the pressure release valve until all steam has been released and safety locking pin has dropped.
11. After all steam is released, turn the pressure release valve to "OPEN" position as illustrated below. Align the arrow on the pressure release valve with OPEN arrow. When it's opened, the pressure release valve sits on a higher position compared to the locked position (low position).

### Side View

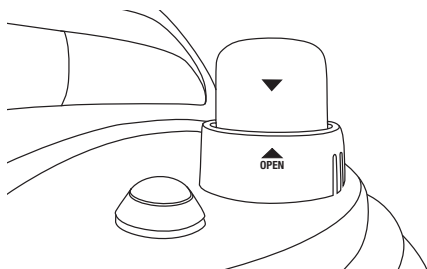

### Top View

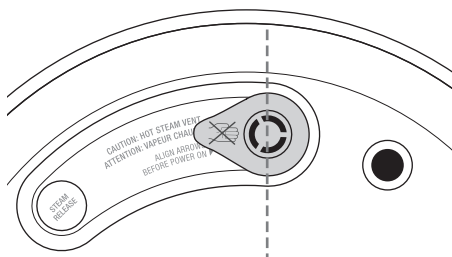

12. Wait 1 minute after releasing pressure before attempting to unlock and remove lid.
13. To open lid turn handle in an anti-clockwise direction until aligning ALIGN arrows to the OPEN position.



### NOTE

This should be effortless!

14. Check food to see if it has been cooked sufficiently. If not, replace lid and lock into position following the previous steps.



### WARNING

Use caution when opening the lid. Steam escapes as soon as the lid is opened. Never place your face or hands over Breville Fast Slow Cooker when removing the lid. Always use oven mitts when handling the hot removable cooking bowl.



### IMPORTANT

- It can take from 30 seconds to 20 minutes to bring the food to pressure, depending on the food and quantity being cooked. To speed this time up use boiling, not cold, liquid.
- Do not fill removable cooking bowl higher than MAX line marking on the inside of the cooking bowl.
- Do not exceed mark line 6 on the inside of the cooking bowl when pressure cooking foods that expand such as rice, dried beans, grains and legumes.



- The minimum amount of combined food and liquid to be added to removable cooking bowl for Pressure Cook recipes cooking in under 10 minutes is 250ml (1 cup). Anything less might boil dry and pressure cook will not function. Additional liquid may need to be added during cooking.
- Never operate appliance when it is empty. Do not cook with less than 1 litre of combined food and liquid.
- Never use oil or milk as a cooking liquid such as deep frying or making custards. Only use hot/warm liquids particularly after sautéing to avoid any damage to the removable cooking bowl. Adding hot liquids also hastens the time to reach pressure.
- Keep hands and face clear of Pressure Release Valve when appliance is in Pressure Cooking operation. Hot steam and water may be emitted during use.
- When cooking under pressure, lid of the Breville Fast Slow Cooker can not be opened. Do not try to force the lid open.
- After making soups and stocks, allow several minutes before releasing pressure and removing lid to make sure that hot liquid inside will not boil over.

## PRESSURE COOK SETTING & CONVERTING CONVENTIONAL RECIPES

Your favourite traditional recipes can be easily adapted to PRESSURE COOK setting. The following charts are a guide to Pressure Cooking times as compared to conventional cooking times.

If trying conventional recipes that are not included in our recipe section, we recommend you calculate that it will cook 70% faster than conventional cooking time.



### NOTE

Time will vary with individual recipes and according to nature of certain foods and quantities. If results are under cooked, close and lock lid, press FUNCTION button until PRESSURE COOK indicator light flashes red.

Set the timer accordingly and press START/CANCEL button to rebuild pressure and cook for required time.

MEAT, POULTRY & SEAFOOD	PRESSURE SETTING	PRESSURE COOK TIME	CONVENTIONAL COOKING TIME
<b>Lamb</b>			
Lamb Shanks 4 x 12-13cm long	HIGH	30-35 minutes	2 hours
Lamb, 2cm diced (1kg)	HIGH	10-12 minutes	1½-2 hours
<b>Beef/Game</b>			
Rolled beef rib roast (1.2kg)	HIGH/then LOW	13-15 minutes	2 hours
Rabbit, pieces (1kg)	HIGH	25-30 minutes	1 ½ hours
<b>Pork</b>			
Spare Ribs (1.2kg)	HIGH	15 minutes	45 minutes
<b>Poultry</b>			
Chicken breast fillets (4 halves)	MEDIUM	2-4 minutes	15-20 minutes
Chicken drumsticks (8)	MEDIUM	10-15 minutes	30-35 minutes
Whole chicken (1.2kg)	MEDIUM	15-20 minutes	1 hour



### NOTE

These cooking times are approximates only and times will vary according to nature of certain foods and quantities.

## PRESSURE COOKING RICE

Wash rice well until water runs clear. Drain well and add rice to removable cooking bowl, measure water or stock using rice duo cup provided and add to removable cooking bowl of Breville Fast Slow Cooker. Secure lid on.

1. Press FUNCTION button then select PRESSURE COOK, indicator light will illuminate.
2. Enter TIME according to type of rice used, ensure displayed on LED.
3. Pressure Release Valve is turned to PRESSURE position and Pressure Control Dial turned to desired setting position. Press START/CANCEL button.
4. Once timer is 0 and 5 beeps sound, release PRESSURE.
5. Open lid. If water has not been completely absorbed, stir rice to evaporate excess moisture before removing.



### NOTE

- When cooking rice, cereals or pasta depressurize slowly after cooking by pressing the Steam Release button in short bursts.
- To speed up the building up of pressure whilst pressure cooking, use boiling water or stock.
- Use rice duo cup supplied with Breville Fast Slow Cooker to measure rice and water. Rice duo cup is not a standard 1 cup Australian metric measure.
- These cooking times are approximates only and times will vary according to nature of certain foods and quantities. If results are under cooked please refer to recipe section for recipes relating to these cooking charts.
- Do not exceed mark line 6 on the inside of the cooking bowl when pressure cooking foods that expand such as rice, dried beans, grains and legumes.

RICE	CUPS	WATER QTY	PRESSURE SETTING	COOK TIME
White long or short grain rice, Jasmine & Basmati rice	2	2 DUO CUPS	LOW	7 MINUTES
	4	4 DUO CUPS	LOW	9 MINUTES
	6	6 DUO CUPS	LOW	10 MINUTES
	8	8 DUO CUPS	LOW	12 MINUTES
	10	10 DUO CUPS	LOW	14 MINUTES
Brown rice	2	2½ DUO CUPS	MEDIUM	15 MINUTES
	4	6 DUO CUPS	MEDIUM	20 MINUTES
	6	9 DUO CUPS	MEDIUM	25 MINUTES
	8	12 DUO CUPS	MEDIUM	30 MINUTES
	10	15 DUO CUPS	MEDIUM	35 MINUTES



### IMPORTANT

Do not use Breville Fast Slow Cooker to cook instant rice.

## PRESSURE COOKING LEGUMES

500g of dried legumes yields approximately 3–4 cups cooked legumes depending on type.

### INGREDIENTS

1 ½ cups dried beans or peas  
3 cups water for cooking

### METHOD

1. Add beans or peas and water to removable cooking bowl of Breville Fast Slow Cooker ensuring not to fill higher than water level mark 6. Secure lid on.

#### Pressure Cook Setting

2. Press FUNCTION button and select PRESSURE COOK, indicator light will illuminate.
3. Enter TIME according to beans or peas used, time is displayed on LED.
4. Pressure Release Valve is to be turned to PRESSURE position and Pressure Control Dial turned to MEDIUM position.

5. Press START/CANCEL button.
6. Once timer is 0 and 5 beeps sound, release PRESSURE.
7. Open lid. Allow to cool then remove and drain beans or peas. Use as required as a substitute for canned beans or peas.



#### TIP

Cooking times recommended in chart are for legumes.

Where a recipe includes cooking of dried legumes with other ingredients, cooking time will need to be increased. As a guide, reduce conventional recipe cooking time by ¾.



#### NOTE

These cooking times are approximates only and times will vary according to nature of certain foods and quantities.

LEGUMES	PRESSURE SETTING	PRESSURE COOK TIME	CONVENTIONAL COOKING TIME
Cannellini beans	MEDIUM	12–15 minutes	40–45 minutes
Chick peas	MEDIUM	35–40 minutes	2 hours
Lima beans, large	MEDIUM	6–8 minutes	30 minutes

## PRESSURE COOKING VEGETABLES

### Ingredients

- 1kg prepared vegetables
- 1 cup water or stock

### Method

1. Add vegetables and water or stock to bowl of Breville Fast Slow Cooker. Secure lid on.
2. Press FUNCTION button and select PRESSURE COOK, indicator light will illuminate.
3. Enter TIME according to vegetable used, time is displayed on LED.
4. Pressure Release Valve is to be turned to PRESSURE position and Pressure Control Dial turned to desired pressure position.
5. Press START/CANCEL button.
6. Once timer is 0 and 5 beeps sound, release PRESSURE.
7. Open lid.

VEGETABLES	PRESSURE SETTING	PRESSURE COOK TIME	CONVENTIONAL COOKING TIME
Beetroot (baby) whole or large beetroots (quartered)	HIGH	6-8 minutes	20-25 minutes
Carrots, 2cm slices	MEDIUM	2-3 minutes	6-10 minutes
Corn on the cob, halved	HIGH	3-4 minutes	10-12 minutes
Pumpkin, diced	LOW	10 minutes	20-30 minutes
Potato, diced for mashing	MEDIUM	8-10 minutes	10-15 minutes
Swede, 2cm slices	HIGH	4-5 minutes	15-20 minutes

FRUIT	PRESSURE SETTING	PRESSURE COOK TIME	CONVENTIONAL COOKING TIME
Apples, whole, 1kg	LOW	5-6 minutes	30 minutes
Peaches, whole, 1kg	LOW	4-5 minutes	20 minutes
Pears, whole, 1kg	LOW	12-15 minutes	30-35 minutes



### NOTE

- These cooking times are approximates only and times will vary according to nature of certain foods and quantities.
- Slow Release - If the Steam release button is not depressed when cooking is finished, the steam will automatically vent out of the pressure release valve slowly. This method is recommended for recipes containing larger quantities of liquid such as soups and casseroles to prevent liquid being forced out with the steam. The Slow release method is also used to finish off recipes such as risottos and puddings.

## HOW TO POT ROAST

The addition of liquid is required for pot roasting. Place meat in removable cooking bowl, then add sufficient liquid to cover up to a third of the meat.

When using SLOW COOK or PRESSURE COOK settings meat will not brown during the pot roasting process, so for browner results seal on the SAUTE/SEAR setting first before pot roasting.

### Suitable meat cuts for pot roasting

MEAT	CUTS
Beef	Topside, Blade, Silverside Roasts, Rump, Rolled Brisket.
Lamb	Forequarter, Shoulder.
Veal	Shoulder/Forequarter.
Pork	Loin, Neck.

## POT ROAST

Serves 4 to 6

### Ingredients

- 1-1.2kg boneless chuck roast
- 2 cloves garlic, peeled and chopped
- 1 tablespoon vegetable oil
- 1 brown onion, peeled and chopped
- 125ml (½ cup) beef stock
- 140g Italian tomato paste
- 400g can diced tomatoes
- 1 tablespoon brown sugar, firmly packed
- 1 teaspoon dry mustard
- ½ teaspoon paprika
- 2 tablespoons lemon juice
- 2 tablespoons cider vinegar
- 1 teaspoon Worcestershire sauce
- 2 tablespoons chopped fresh parsley

### Method

Rub meat all over with crushed garlic.

### Sauté Setting

1. Press FUNCTION button then select SAUTÉ, ensure indicator light illuminates. Enter 15 minutes TIME, time is displayed on LED. Press START/CANCEL button and wait 3 minutes while bowl is heating before cooking.
2. Add meat and brown well on all sides. Remove meat and set aside.
3. Heat oil for 20 seconds and add onions, sauté for 2-3 minutes until onions have softened.
4. Add beef stock, tomato paste, diced tomatoes and juice, brown sugar, dry mustard, paprika, lemon juice, cider vinegar and Worcestershire sauce.
5. Stir well until all ingredients are well mixed and bring mixture to the boil.
6. Return meat to Breville Fast Slow Cooker and turn to coat all over with sauce. Secure the lid on.

### Pressure Cook Setting

7. Press FUNCTION button then select PRESSURE COOK, indicator light will illuminate.
8. Enter 45 minutes TIME, time is displayed on LED.
9. Pressure Release Valve is to be turned to PRESSURE position and Pressure Control Dial turned to MEDIUM position.
10. Press START/CANCEL button.
11. Once timer is 0 and 5 beeps sound, release PRESSURE.
12. Open lid. Check beef, it should be soft when pierced with a knife. Remove meat and slice and return to Breville Fast Slow Cooker for 10 minutes before serving. Garnish with chopped parsley and serve.



### NOTE

If you would like to slow cook this recipe follow the SLOW COOK instructions on page 32-35 and set for 6 or 8 hours.

## HOW TO ROAST

Roasting meats using either **PRESSURE COOK** or **SLOW COOK** settings, creates tender, flavoursome results. Both cooking processes break down and soften the connective and muscle tissue within the meat, making it easier to slice.

Meat will not be browned during **PRESSURE COOK** or **SLOW COOK** settings, so for seared results use the **SAUTÉ/SEAR** setting first.

### Using **SLOW COOK** or **PRESSURE COOK** Setting

Elevate the meat to be cooked on provided stainless steel trivet. Add a minimum of 250ml (1 cup) hot liquid (water or stock).

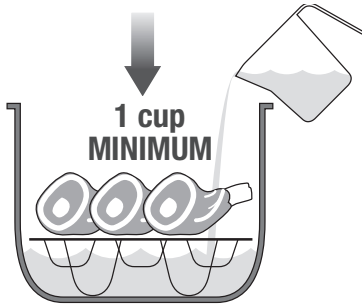

This will assist in keeping the surface of the meat dry and free from any fat released throughout the cooking process. The stainless steel trivet rack will keep the meat, raised above the boiling liquid.

### **NOTE**

- Do not use oil or milk as a liquid.
- The **SLOW COOK** or **PRESSURE COOK** functions will stop operating or timer function stops counting down if insufficient liquid. Add more liquid, make sure at all times a minimum 1 litre (4 cups) liquid is in cooking bowl during cooking.

## Suitable meat cuts for roasting

MEAT	CUTS
<b>Beef</b>	Blade, Rump, Rib Roast, Fresh Silverside, Topside.
<b>Lamb</b>	Leg, Mid Loin, Rack, Crown Roast, Shank, Shoulder, Mini Roasts.
<b>Veal</b>	Leg, Loin, Rack, Shoulder/Forequarter.
<b>Pork</b>	Loin, Neck, Leg, Racks (remove skin & fat).

## BASIC ROAST

### Ingredients

1-1.2 kg beef, veal, lamb or pork roast or whole 1.2kg chicken

250ml (1 cup) beef or chicken stock

### Method

#### Sauté Setting

1. Press **FUNCTION** button then select **SAUTE**, indicator light will illuminate.
2. Enter 10 minutes **TIME**, time is displayed on LED.
3. Press **START/CANCEL** button and wait 3 minutes while bowl is heating before cooking. Add meat and brown well on all sides. Remove meat and set aside. Add beef stock or chicken stock and mix with spatula. Carefully place trivet into the bowl. Place meat onto trivet.

## Pressure Cook Setting

1. Press FUNCTION button and select PRESSURE COOK, ensure indicator light illuminates.
2. Enter 13 minutes for rare or 15–18 minutes for medium to well done TIME, time is displayed on LED.
3. Pressure Release Valve is turned to PRESSURE position and Pressure Control Dial turned to LOW position.
4. Press START/CANCEL button.
5. Once timer is 0 and 5 beeps sound, release PRESSURE.
6. Open the lid. Rest meat on a plate, covered with foil for 10 minutes before carving. Season to taste and serve.



### NOTE

If you would like to slow cook this recipe follow the slow cook instructions on page 32–35 and set for 6 or 8 hours.

## SLOW COOK SETTING

Breville Fast Slow Cooker has been designed specifically with a unique Slow Cook setting for flavour layering. A technique professional chefs use to enhance and deepen the taste of meals by using the same cooking bowl for sautéing onions and searing meats and creating casseroles, curries, soup, stock and bolognaise.

With Breville Fast Slow Cooker you can now sauté and slow cook in the cooker using the same non stick cooking bowl. Simply activate SAUTÉ/SEAR function to caramelize vegetables and sear meats and then start to SLOW COOK.

SLOW COOK setting on Breville Fast Slow Cooker will gently simmer food for an extended period of time.

The following is a guide to adjusting your favourite recipes:

TRADITIONAL COOKING TIME	SLOW COOK SETTING TIME
60–120 minutes	6 or 8 hours

## HOW TO SLOW COOK

1. Place removable cooking bowl into stainless steel base.

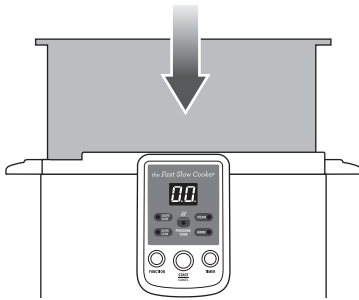

2. Attach clean silicone rubber gasket securely into gasket holder. Ensure that the gasket is installed correctly.



### NOTE

Fit silicone rubber sealing gasket into lid if not already in place.

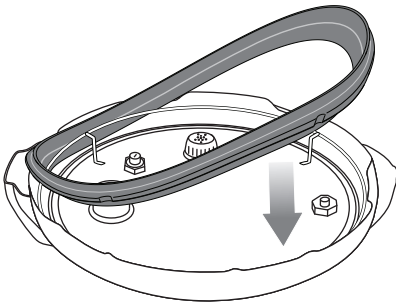

3. Place a minimum of 1 litre of combined food and liquid into removable cooking bowl.



4. Close and lock lid by using handle. Close lid in an clockwise direction by aligning ALIGN arrows. Lid arrow should align with stainless steel base arrow until it locks into place and is in the CLOSE position.



### NOTE

This should be effortless!

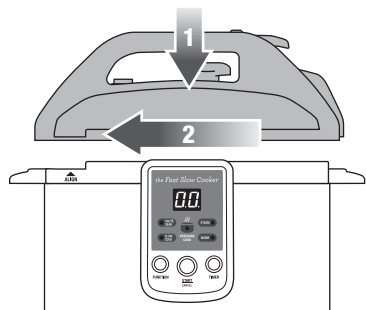

### NOTE

pressure release valve and control dial is not relevant when slow cooking.



5. Press FUNCTION button until SLOW COOK indicator light flashes red.

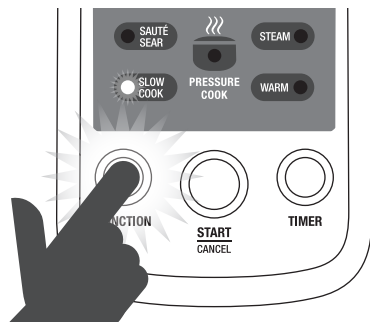

6. To set TIMER; press TIMER button and choose either 6 hours or 8 hours, 6H or 8H this will illuminate on LED display. When desired cooking time is displayed, press START/CANCEL button. The function indicator light will stop flashing and will illuminate a solid red.
7. Preheating will begin, control panel will continue to display selected cooking time, and count down in hour increments until last hour and this hour will countdown in minutes on LED display.
8. When LED displays 0 cooking has finished. Breville Fast Slow Cooker will sound 5 beeps and will automatically switch to KEEP WARM setting for 30 minutes.



9. To open lid turn handle in an anti-clockwise direction until aligning ALIGN arrows to OPEN position.



## NOTE

This should be effortless!



## IMPORTANT

Do not use Breville Fast Slow Cooker to cook instant rice.

- Never use SLOW COOK setting without food and liquids in the removable cooking bowl.
- Always have lid closed throughout the operation of the SLOW COOK setting.
- Always use dry pot holders or oven mitts to remove cooking bowl when hot.
- Do not place removable cooking bowl or stainless steel lid when hot on any surface that may be affected by heat.



## WARNING

Always open stainless steel lid carefully and away from yourself to avoid scalding from escaping steam.

## Using the Keep Warm Function



## NOTE

**Automatically** – after slow cooking has finished, keep warm will function for 30 minutes.

**Manual** – select keep warm function and time can be programmed from 02 to 99 minutes.

## HOW TO STEAM

1. Place stainless steel trivet inside removable cooking bowl and add 1 litre (4 cups) of hot liquid (water or stock). Place stainless steel steaming basket containing food onto trivet using handle.

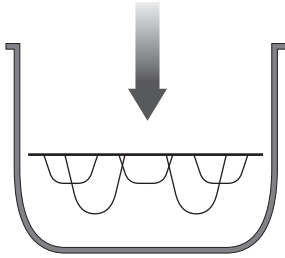

2. Close and lock lid by using handle. Close lid in an clockwise direction by aligning ALIGN arrows. Lid arrow should align with stainless steel base arrow until it locks into place and is in the CLOSE position.



### NOTE

This should be effortless!

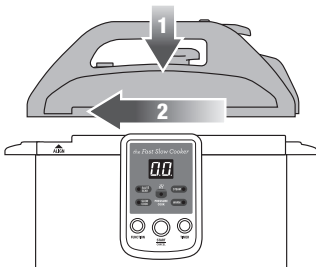

3. Select one of the following settings using the pressure release valve Control dial located on the handle:
  - Low (Low Pressure).
  - Medium (Moderate Pressure).
  - High (High Pressure).

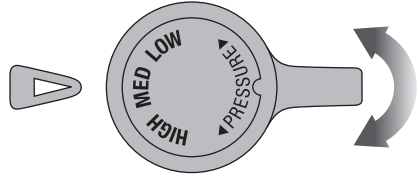

4. Ensure Pressure Release Valve is turned to PRESSURE position.
5. Press FUNCTION button until STEAM indicator light flashes red.
6. To set TIMER; press TIMER button to increase the cooking time this will be illuminated on LED display from 02 minutes to maximum 99 minutes. To fast advance time, press and hold down TIMER button. When desired cooking time is displayed, press START/CANCEL button. The function indicator light will stop flashing and will illuminate a solid red. Preheating will begin, control panel will continue to display selected cooking time. As selected pressure setting is achieved, there will be a slight hissing of steam from pressure release valve. After approximately 10 minutes, or more depending on the amount of liquid added to cooking bowl, selected cooking time will begin to count down in minutes and this is shown on LED display.
7. When LED displays 0 cooking has finished. Breville Fast Slow Cooker will sound 5 beeps.
8. To release pressure from pressure release valve; press pressure release button. Steam can be released in the following two ways:

## NOTE

**Quick Release** – This method uses the Stream Release Button. Depress in short bursts until all steam is out of the pressure release valve.

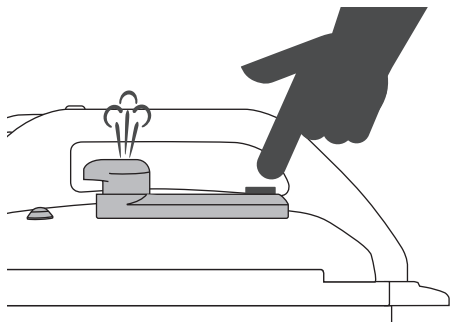

## IMPORTANT

Stream Release Button will be hot if pressed for prolonged period.

## NOTE

**Slow Release** – If the Steam release button is not depressed when cooking is finished, the steam will automatically vent out of the pressure release valve slowly. This method is recommended for recipes containing larger quantities of liquid such as soups and casseroles to prevent liquid being forced out with the steam. The Slow release method is also used to finish off recipes such as risottos and puddings.

Release steam by using method recommended in recipe.

9. Wait minimum 1 minute after releasing pressure/steam to unlock and remove lid. To open lid use handle in a anti-clockwise direction until aligning ALIGN arrows to the OPEN position.

## NOTE

This should be effortless!

10. Check food to see if it has been cooked sufficiently. If not, replace lid and lock into position following the previous step 4.

## IMPORTANT

- STEAMING function in Breville Fast Slow Cooker operates under pressure so Keep hands and face clear of Pressure Release Valve when appliance is in Steaming operation Hot steam and water may be emitted during use.

## CAUTION

- When steaming the lid can not be opened. Do not try to force the lid open.
- Use Caution when opening lid. Steam escapes as soon as the lid is opened. Never place hands and face over Breville Fast Slow Cooker when removing the lid. Always use oven mitts when handling the hot removable cooking bowl.

## BASIC STEAMING CHART

FOOD	TIME
Beetroot	20-25 minutes
Brussels sprouts	8-10 minutes
Parsnips	5-6 minutes
Pumpkin 2cm pieces	10-12 minutes

### Basic Steamed Vegetables

Select vegetable from basic steaming chart.

1 litre water or stock.

Place trivet into removable cooking bowl of Breville Fast Slow Cooker and pour in 1 litre water or stock. Place steaming basket of vegetables onto trivet. Secure lid on.

### STEAM in Breville Fast Slow Cooker

1. Press FUNCTION button then select STEAM, indicator light will illuminate.
2. Enter recommended TIME for selected vegetable, time will be displayed on LED.
3. Pressure Release Valve is turned to PRESSURE position and Pressure Control Dial turned to LOW position.
4. Press START/CANCEL button.  
Once timer is 0 and 5 beeps sound, release PRESSURE.
5. Open lid.

To avoid overcooking foods when using the STEAM function, it is generally a good idea to release steam and remove lid to stop cooking immediately. Remove the steaming basket by the handles.



## Care & Cleaning

1. Before cleaning Breville Fast Slow Cooker, switch off at power outlet, unplug from power outlet and remove the connector end of power cord from appliance inlet.
2. Wash removable cooking bowl with warm soapy water and a clean soft cloth or sponge. Rinse with clean water and dry thoroughly.

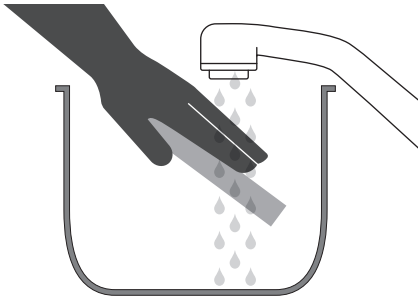

### NOTE

Removable cooking bowl can be washed in dishwasher. However, to maintain non stick coating, it is recommended to wash cooking bowl in hot, soapy water using a mild household detergent. Rinse and dry thoroughly.



### WARNING

Do not use abrasive cleaners, steel wool or scouring pads as these can damage the surfaces and non-stick coating.

3. Stainless steel base can be wiped over with a soft, damp cloth and then dried thoroughly.
4. Remove condensation collector by gently pulling downwards and clean it thoroughly under water. Place it back in its original position.

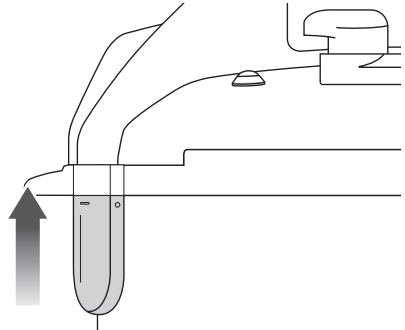
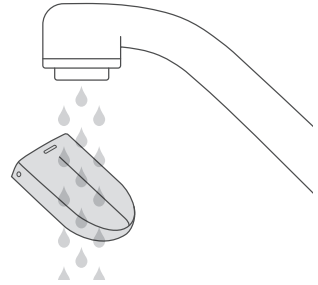
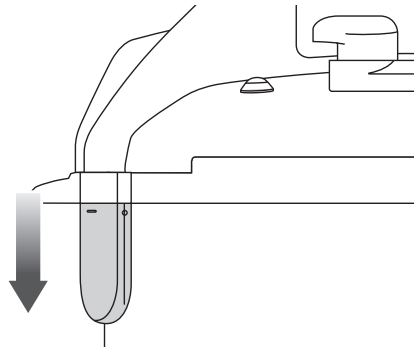

5. Disassemble lid.
  - a) Gently pull the silicone rubber gasket out from under the gasket holder. Check periodically that it is clean, flexible and not cracked or torn. If damaged do not use the appliance.



## WARNING

- Do not use abrasive cleaners, steel wool or scouring pads.
- Do not immerse metal base or power cord in water or any other liquid as they may cause electrocution.
- Ensure removable cooking bowl is correctly positioned in the base before you commence cooking.



## NOTE

After cooking rice or large meals, some cooking liquid may pool under lid at the top of appliance around the cooking bowl. This is normal. Use a paper towel or kitchen cloth to clean after every use. Use a small brush or cotton swab if necessary.

Call **The Breville Customer Service Centre**.  
**Phone: 1300 139 798** to order a replacement.



## NOTE

- Replace silicone rubber gasket every 1-2 years (see your nearest Breville Service Centre).
- Wash gasket in warm, soapy water. Rinse with clean water, dry thoroughly and place back in their original position.
- The silicone rubber gasket can be washed in the top rack of a dishwasher to eliminate odour from spices.
- Can soak silicone rubber gasket in a mixture of bicarbonate soda and water to help eliminate odours before cleaning.
- During cleaning of the lid ensure safety locking pin moves freely (up and down). Wash and clean any oil or food residue from this area.



## WARNING

If the silicone rubber gasket is not fitted correctly into the holder, the lid will not seal properly. This may cause the appliance to malfunction and leak steam or hot liquid which can cause burns or scalding.

- Wash the inside of the lid with a wet, soapy sponge or cloth. Use a brush to remove oil residue if necessary. Wipe dry with a clean, damp cloth.
- Regularly inspect that Pressure Release Valve Cover is clean and free of liquid/food. Remove pressure release valve cover from the lid (by twisting and lifting up and off the Lid) and wipe over with a soapy cloth and dry clean. Rinse well and replace by clipping back in place.

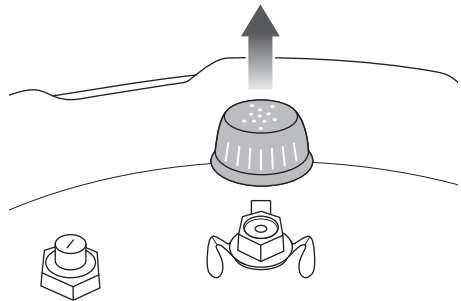

- d) Pressure Safety Valve will need to be regularly checked and cleaned in order to avoid any clogging which could result in blocking the safety valve.

To clean the Pressure Safety Valve, push valve from inside the lid in and out with a long thin object (e.g. chopstick, screwdriver). Wash and clean any oil or food residue. Ensure the valve moves in and out smoothly after cleaning.

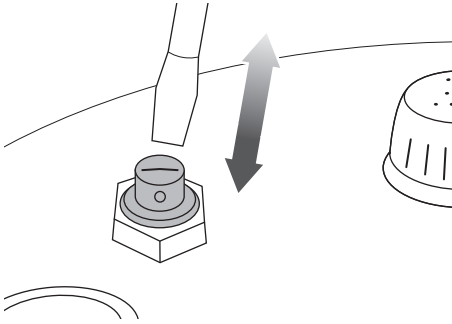

#### IMPORTANT

All lid parts must be reassembled correctly to ensure safety as well as optimal performance of your Fast Slow Cooker.



#### NOTE

A mixture of 1 tablespoon vanilla, ½ cup lemon juice, 1 tablespoon lemon rind plus 500ml hot water, cook at HIGH pressure for 5 minutes. Leave to slow release pressure, then disassemble and wash as directed, can help eliminate food odours.



# Troubleshooting

## POSSIBLE

## EASY SOLUTION

EO is displayed on LED Screen

- Check that lid is closed properly.
- Check that the Pressure Release Valve is in the correct position.
- Make sure the silicone rubber gasket is in good condition and attached properly to the gasket holder.

E1 is displayed on LED Screen

- Unplug unit and allow to sit for 20 minutes. If no change, Please call Breville Consumer Service.

E2 is displayed on LED Screen

- Ensure the cooking bowl is properly positioned inside base. The cooking bowl must be in direct contact with the heating plate. Make sure there are no unwanted materials on the heating plate.

E3 is displayed on LED Screen, Beeping

- SAUTE/SEAR setting will not work if the lid is on or locked in position. Ensure the lid is off or placed on top of the appliance in an offset position.

The appliance automatically switches to Keep Warm without going through a complete cooking cycle

- Add more water to cooking bowl and restart the cooking cycle.

Air is escaping from the rim of the lid

- Make sure the silicone rubber sealing gasket is in good condition and attached properly to the gasket holder.
- Check that lid is closed properly.

Steam is released from the safety locking pin during cooking

- Inspect the safety locking pin (see page 11, letter "U"). The pin should move up and down freely, and have a silicone seal on one end. Clean the pin and replace the seal if necessary.
- Make sure the silicone rubber sealing gasket is in good condition and attached properly to the gasket holder.

The safety locking pin does not rise in PRESSURE COOK setting

- Place Pressure release valve in the correct position.
- Place more food and water in the cooking bowl.
- Call Breville Customer Service.



## POSSIBLE

## EASY SOLUTION

---

Lid is hard to open or cannot be opened

- After all internal pressure is released, the lid should be effortless to open. It should only require the use of one hand in a smooth action.
- If the lid will not unlock or you encounter resistance, it may indicate the appliance is still under pressure. Never force the lid open as any remaining pressure can be hazardous.
- Press the steam release button until all internal pressure is released and the cooker can be opened.
- If there is no more steam coming from the valve, the safety locking pin is still in the locked position. Gently tap on the handle to unlock the pin and open the lid.
- If resistance is still encountered, disconnect from the power supply and allow the pressure cooker to cool down to room temperature. Never force the lid open.

---

Lid is difficult to close

- Make sure the silicone rubber gasket is attached properly to the gasket holder.

---

E2 is displayed on LED Screen

- It can take from 30 seconds to 20 minutes to bring food to pressure, depending on the food and quantity being cooked. To speed up this time, use hot, not cold liquid.

If problem persists:

- Check that lid is closed properly.
- Check that the Pressure Release Valve is in the correct position.
- Make sure the silicone rubber sealing gasket is in good condition and is attached properly to the gasket holder.
- Inspect the safety locking pin (see page 11, letter "U"). The pin should move up and down freely, and have a silicone seal on one end.

---

Never gets to pressure/  
Time not counting down.

- It can take from 30 seconds to 20 minutes to bring food to pressure, depending on the food and quantity being cooked. To speed up this time, use hot, not cold liquid.

If problem persists:

- Check that lid is closed properly.
  - Check that the Pressure Release Valve is in the correct position.
  - Make sure the silicone rubber sealing gasket is in good condition and is attached properly to the gasket holder.
  - Inspect the safety locking pin (see page 11, letter "U"). The rod should move up and down freely, and have a silicone seal on one end.
-



Notes



Notes

## Breville Customer Service Centre

### Australian Customers

**Mail:** Locked Bag 2000  
Botany NSW 1455  
AUSTRALIA

**Phone:** 1300 139 798

**Fax:** (02) 9700 1342

**Email:** Customer Service:  
askus@breville.com.au

**Web:** [www.breville.com.au](http://www.breville.com.au)

### New Zealand Customers

**Mail:** Private Bag 94411  
Botany Manukau 2163  
Auckland NEW ZEALAND

**Phone:** 0800 273 845

**Fax:** 0800 288 513

**Email:** Customer Service:  
askus@breville.co.nz

**Web:** [www.breville.co.nz](http://www.breville.co.nz)

**Breville®**  
Thought for food

Breville is a registered trademark of Breville Pty. Ltd. A.B.N. 98 000 092 928.  
Copyright Breville Pty. Ltd. 2015.

Due to continued product improvement, the products illustrated/photographed  
in this brochure may vary slightly from the actual product.